

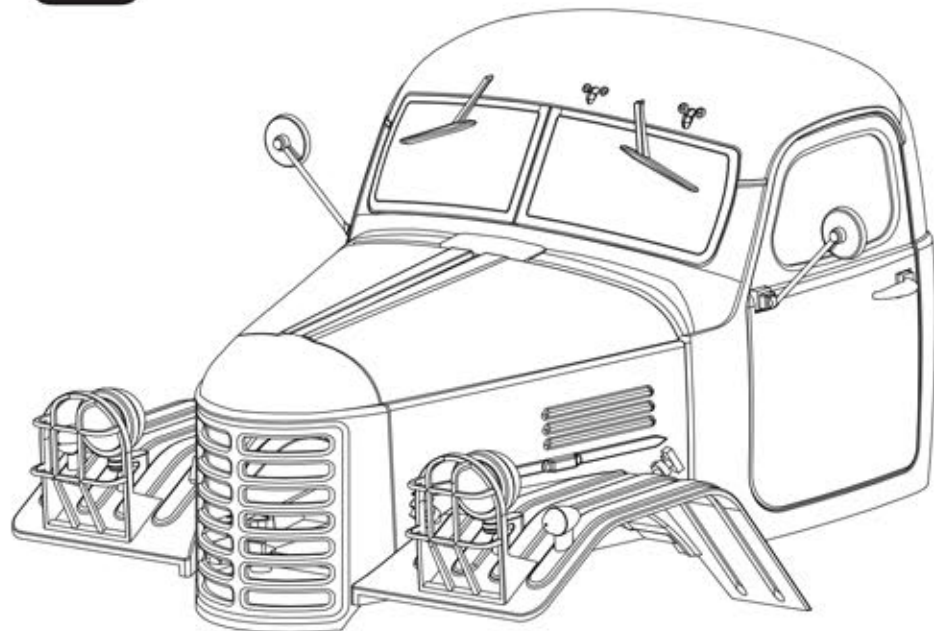

KINGKONG R/C

# CA30



# CA30

车壳说明书



## 推荐工具

## RECOMMENDED TOOLS



十字螺丝刀  
BOLT DRIVER

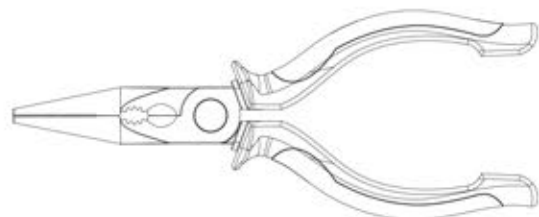

尖嘴钳  
LONG NOSE PLIERS

## 安装提示:

## TIPS FOR ASSEMBLY:

使用好质量的螺丝刀, 避免磨损螺丝头

USE GOOD QUALITY HEX DRIVERS TO AVOID STRIPPING SCREW HEADS.

当将金属螺丝拧进金属部件时, 请使用螺纹胶

USE THREAD LOCK WHEN PUTTING METAL SCREWS INTO METAL PARTS.

不要将螺丝拧太紧, 否则将会磨损螺纹

DO NOT OVER TIGHTEN SCREWS OTHERWISE YOU MAY STRIP THE THREAD.

17



M3x10MM PB x2

17

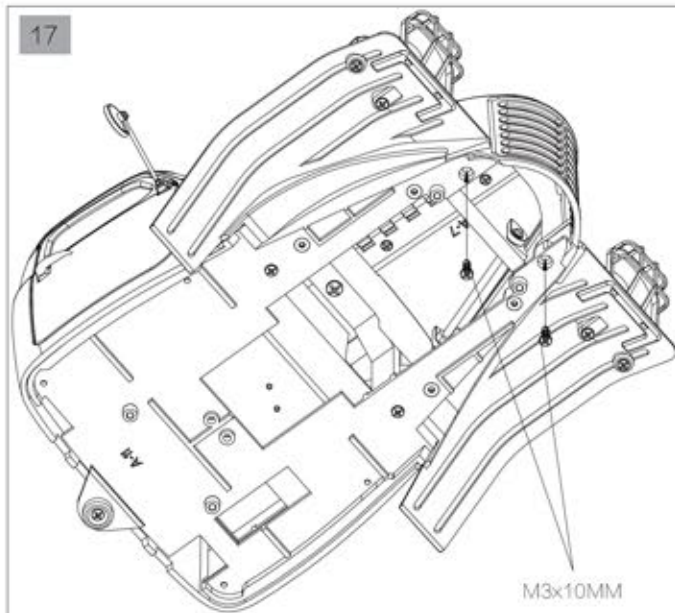

M3x10MM

18

18



车壳完成

## FJ30-A3-Screw(x1)



M2.5x5mm PWB x2



M3x8mm PB x9



M4x16mm x1



2.0MM 卡黄 x4



M3x4MM PB x4



M2.5x6MM PB x4



M3x6mm 平头内六角 x4



M3x10MM PB x2

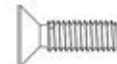

M4x13mm PB x1

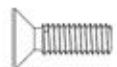

M4x13mm PB x1

15

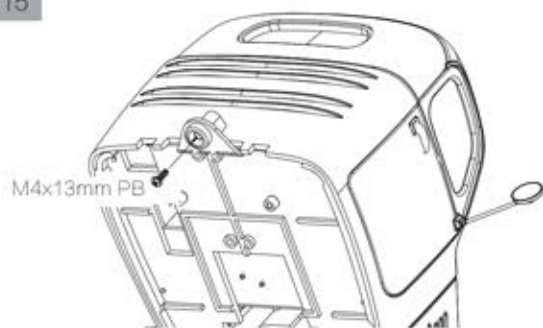

M4x13mm PB

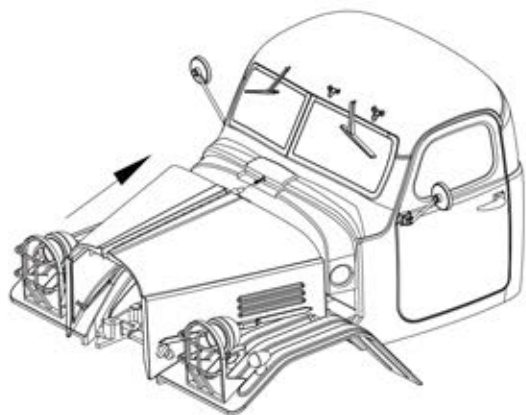

16

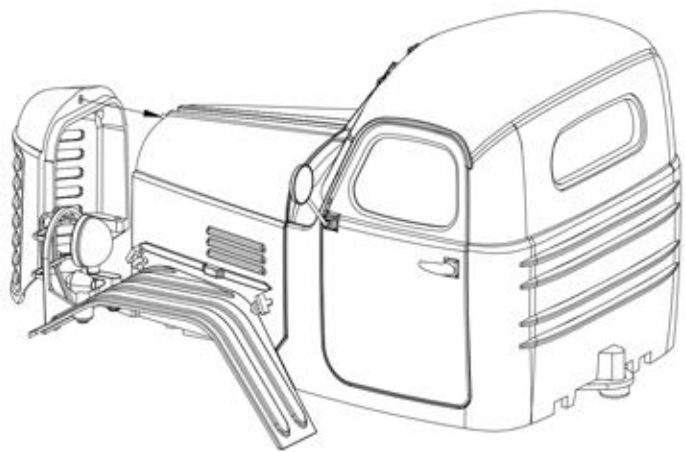

M2.5x5mm PWB x2

1

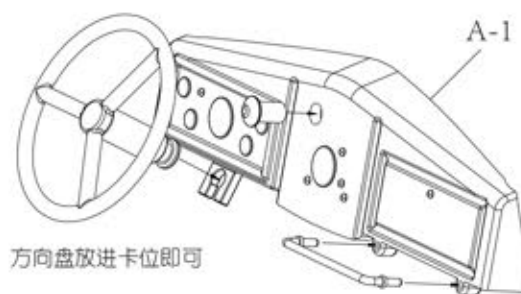

方向盘放进卡位即可

使用ABS胶水粘合晾干即可

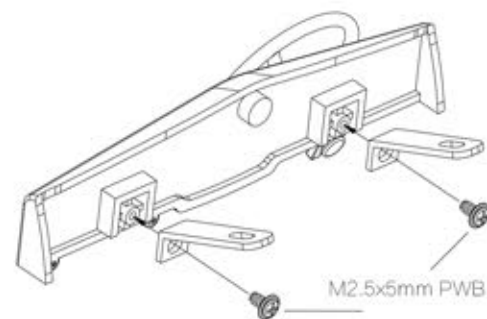

M2.5x5mm PWB

2

2

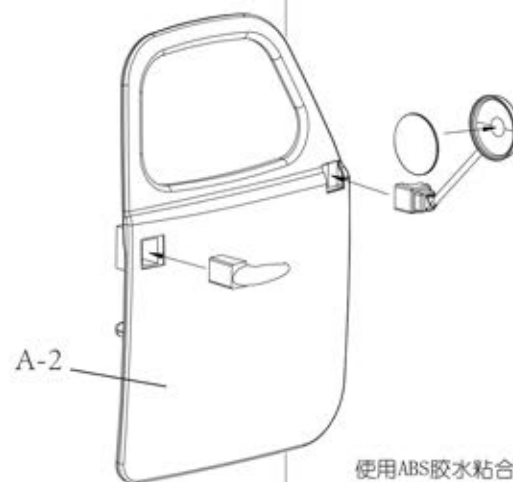

A-2

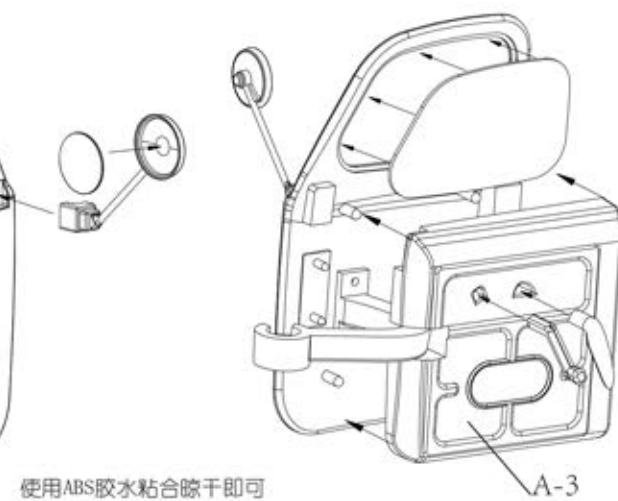

使用ABS胶水粘合晾干即可

A-3

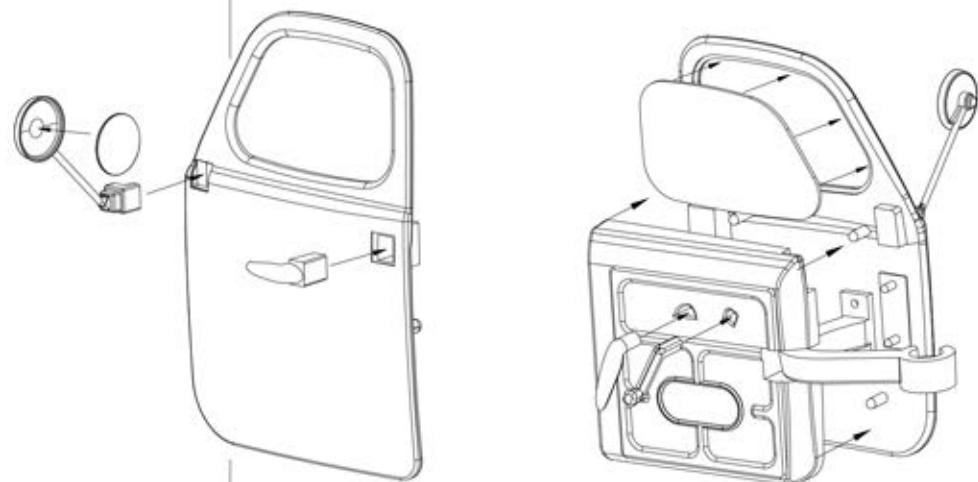

使用ABS胶水粘合晾干即可

  
M3x8mm PB x2

M3x8MM



使用ABS胶水粘合晾干即可

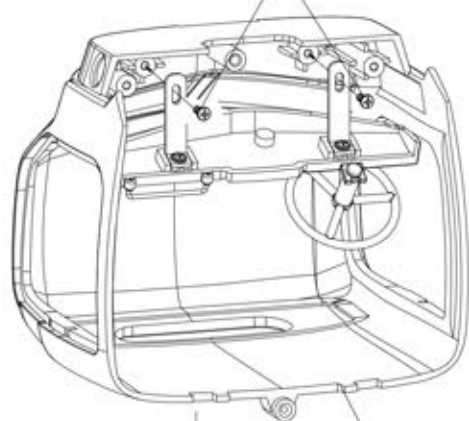

A-4

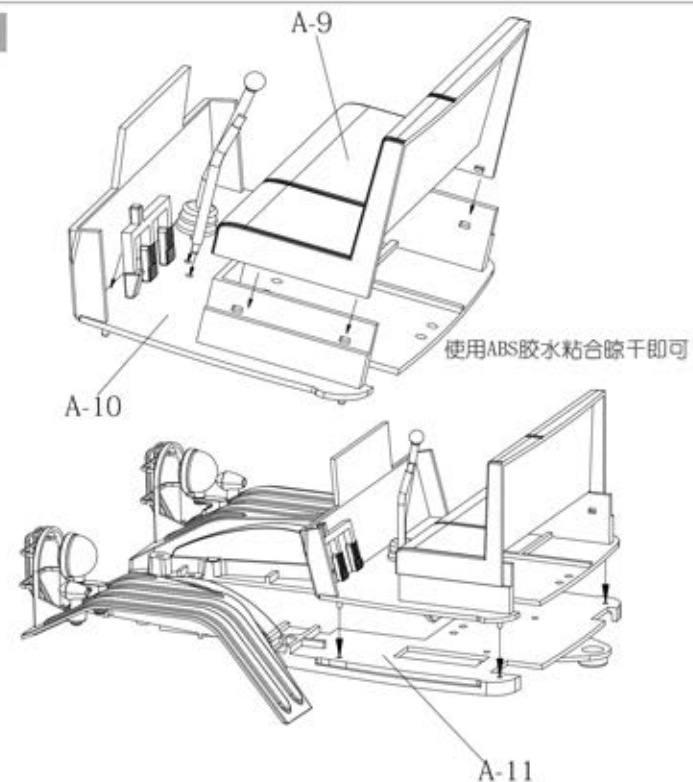

使用ABS胶水粘合晾干即可

A-11

  
M3x8mm PB x2

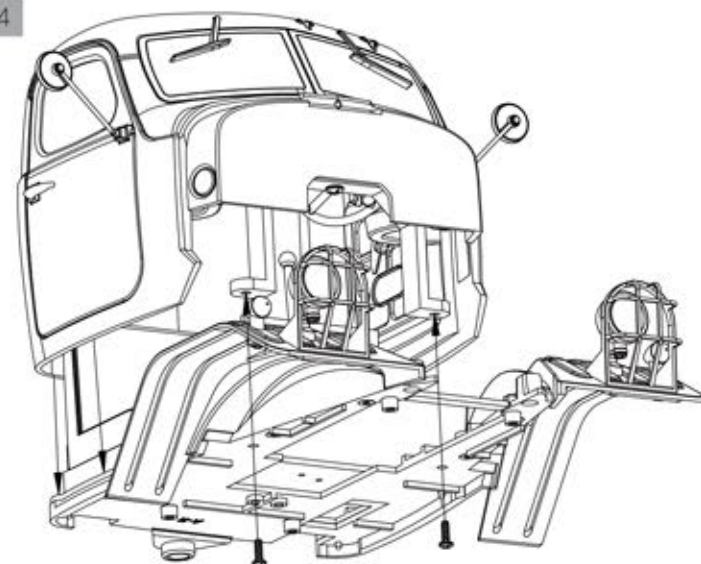

M3x8mm PB



M3x8mm PB x2



M2.5x6MM PB x2

11

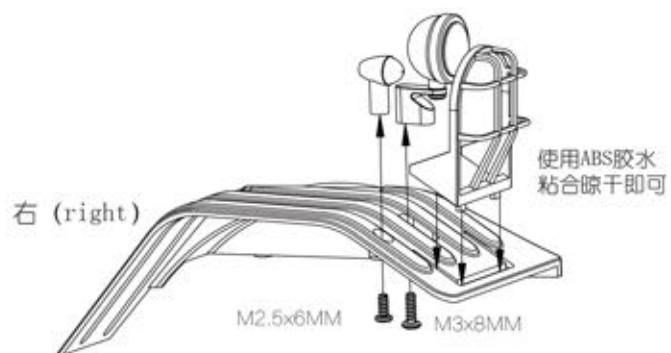
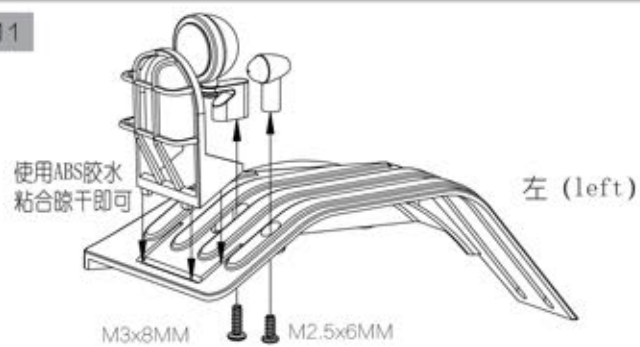

M3x6mm 平头内六角 x 4

12

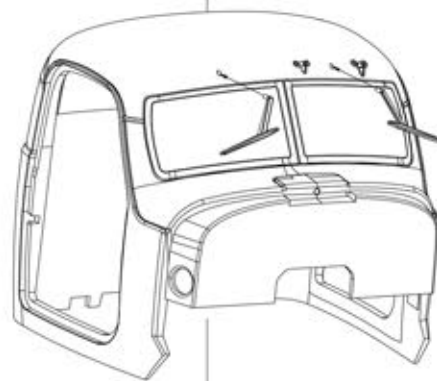
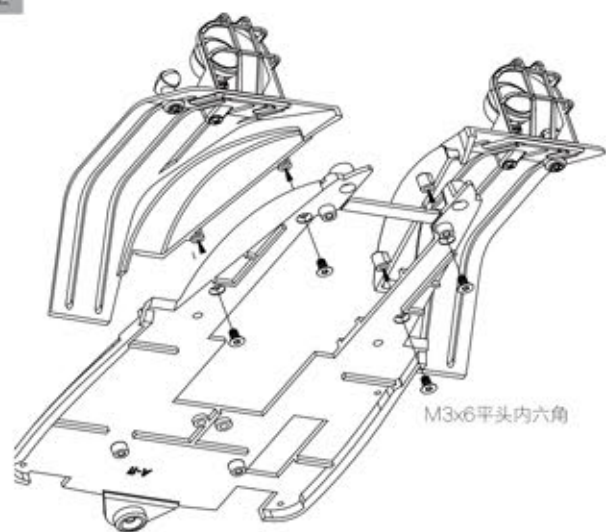

10MM磁铁 x2

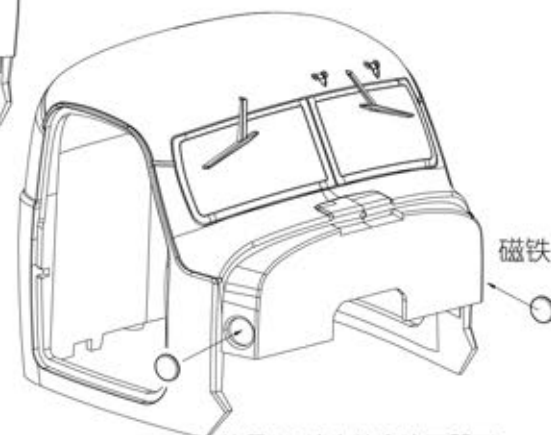

磁铁

使用ABS胶水粘合晾干即可



M3x8mm PB x1



12X4.5X1垫片

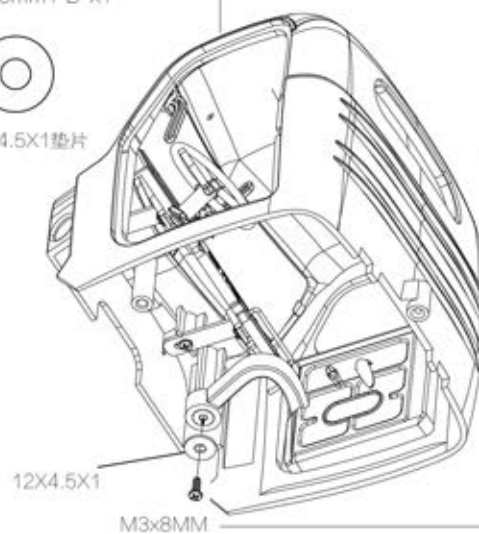

12X4.5X1

M3x8MM

6

使用ABS胶水粘合晾干即可

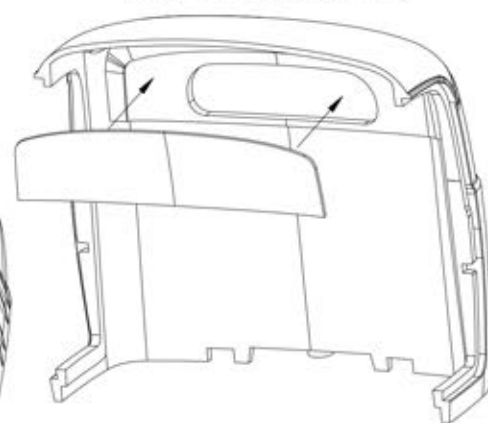

M3x8mm PB x1

12X4.5X1垫片

M4x16mm x1

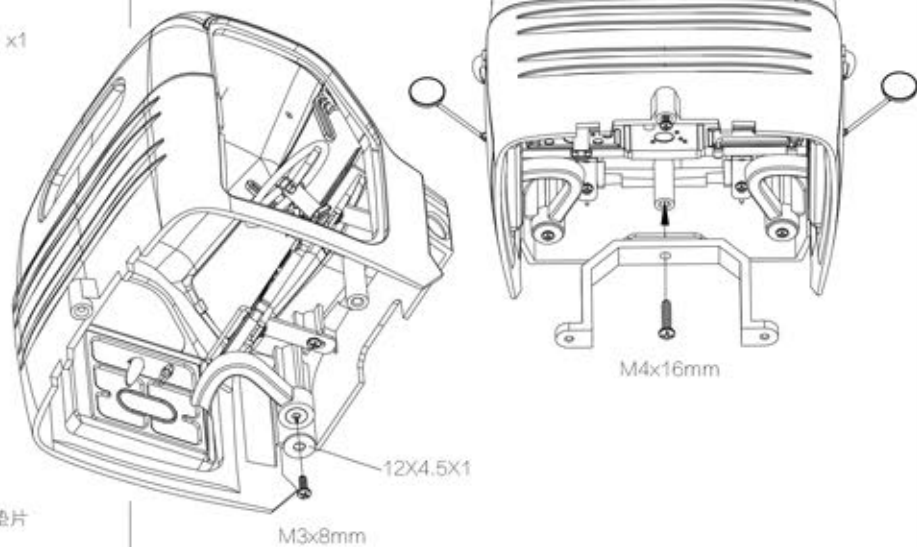

M3x4MM PB x4

2.0MM 卡簧 x2

10MM磁铁 x1

3x63.5MM

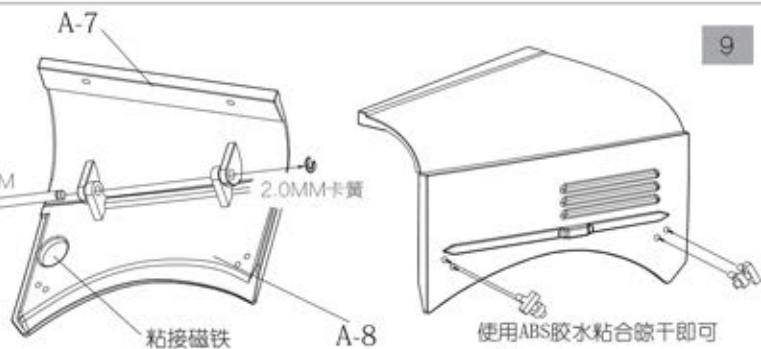

3x63.5MM

2.0MM 卡簧 x2

10MM磁铁 x1

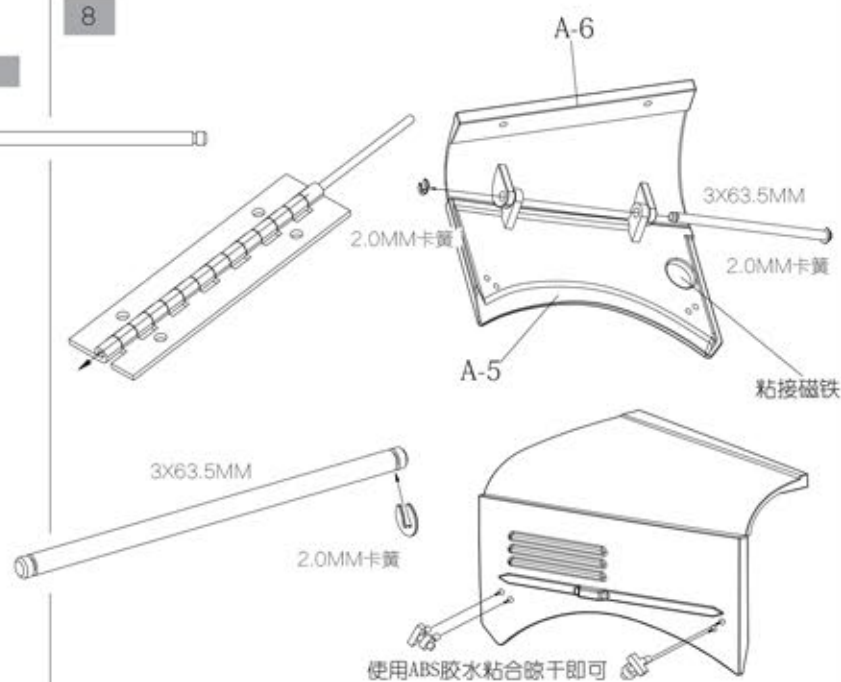

M2.5x6MM PB x2

