

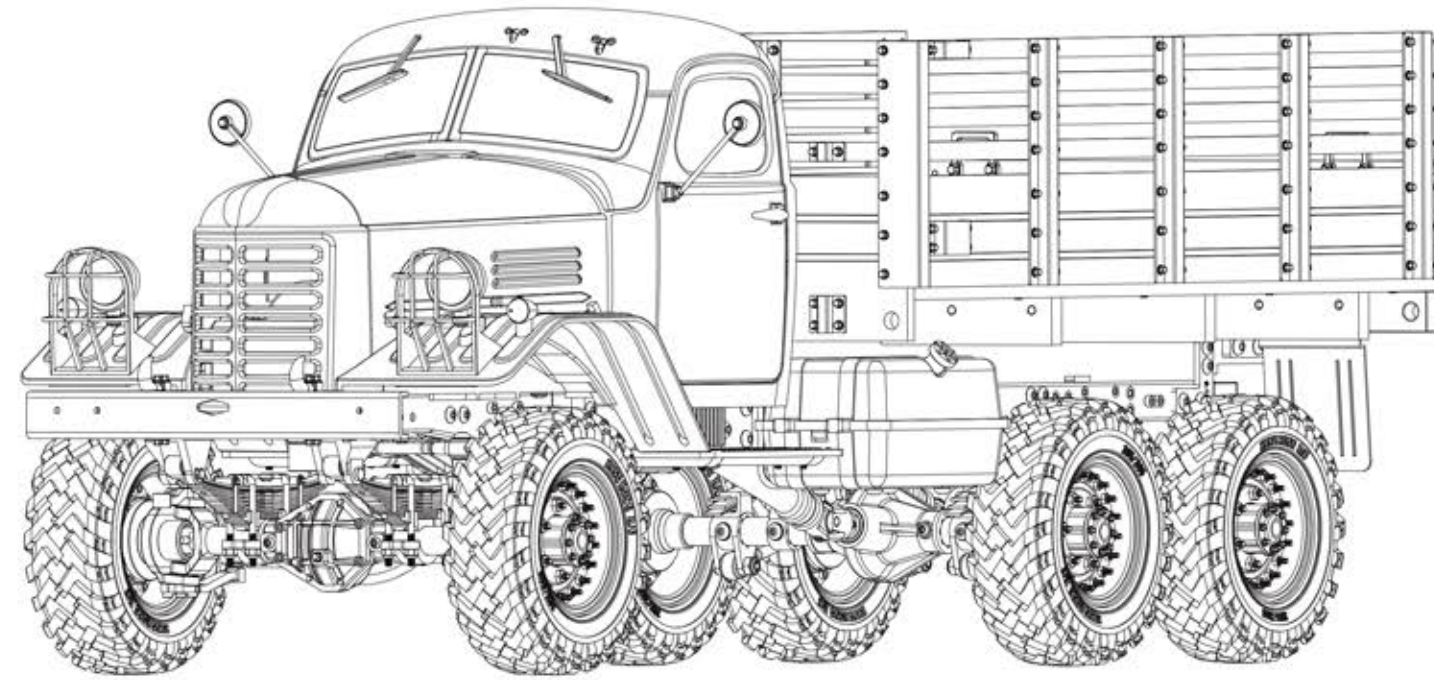

CA30



CA30

1/12TH SCALE R/C 6X6 LIGHT TRUCK



推荐工具

RECOMMENDED TOOLS

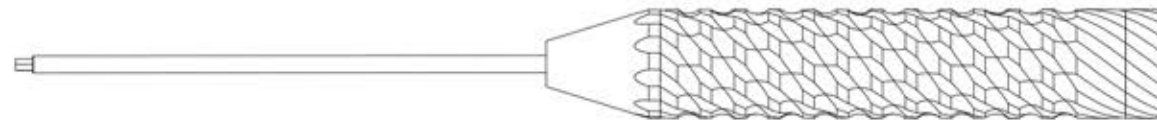

内六角螺丝刀
HEX DRIVERS (1.5MM, 2MM, 2.5MM)

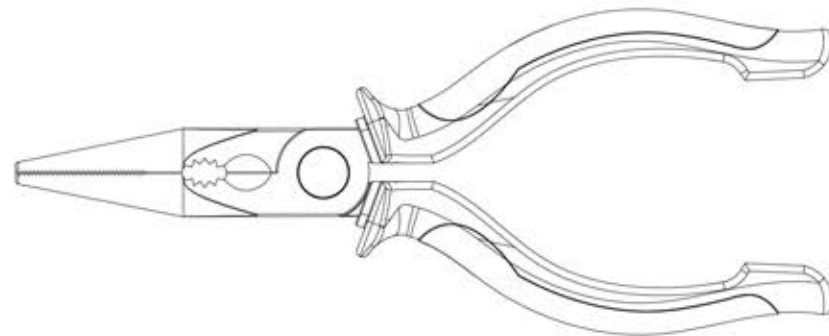

尖嘴钳
LONG NOSE PLIERS



套筒

WRENCH (2.0MM, 2.5MM)
黑色螺丝盒中配有原厂套筒

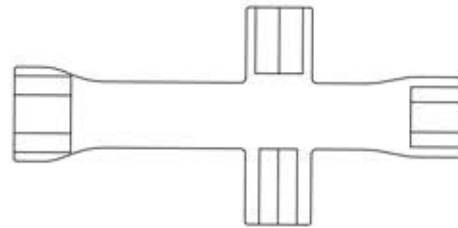

十字套筒
CROSS WRENCH



安装提示:

TIPS FOR ASSEMBLY:

使用好质量的螺丝刀，避免磨损螺丝头

USE GOOD QUALITY HEX DRIVERS TO AVOID STRIPPING SCREW HEADS.

当将金属螺丝拧进金属部件时，请使用螺纹胶

USE THREAD LOCK WHEN PUTTING METAL SCREWS INTO METAL PARTS.

不要将螺丝拧太紧，否则将会磨损螺纹

DO NOT OVER TIGHTEN SCREWS OTHERWISE YOU MAY STRIP THE THREAD.









金鋼製造 (香港) 有限公司
KING KONG MFG ING LIMITED

制造商：东莞市豪鼎模型技术有限公司
地址：广东省东莞市凤岗镇天堂围兴业路3号
产地：广东省东莞市
support@kkrcn.com

FJ30-A1-CHM(×4)

-  M2.5x6mm 杯头内六角 x6
-  M2x4mm 杯头内六角 x12
-  M2x6mm 杯头内六角 x12
-  M1.6x6mm 杯头内六角 x 108

FJ30-B1-TM(×9)

-  M3x4mm 半圆头内六角 x4
-  M3x6mm 半圆头内六角 x16
-  M3x8mm 半圆头内六角 x17
-  M3x10mm 半圆头内六角 x7
-  M3x12mm 半圆头内六角 x 4
-  M3x14mm 半圆头内六角 x 4
-  M3x22mm 半圆头内六角 x1
-  M2.5x6mm 半圆头内六角 x20
-  M2.5x8mm 半圆头内六角 x12

FJ30-C1-HWM(×3)

-  M2x4mm 外六角 x 28
-  M2x8mm 外六角 x 4
-  M2x6mm 外六角 x 4

FJ30-D1-KM(×2)

-  M2x6mm 平头内六角 x8
-  M3x6mm 平头内六角 x2

FJ30-E1-JM(×1)

-  M3x8mm 机米螺丝 x10

FJ30-F1-CH(×4)

-  M1.6螺母 x 108
-  M2 螺母 x 36
-  M3防松螺母 x 4
-  2mm 卡簧 x6

1

-  M2.5x6mm 杯头内六角 x 3
-  M2.5x6mm 半圆头内六角 x1



2



-  M2.5x6mm 半圆头内六角 x 2

-  M2x4mm 杯头内六角 x 4



3

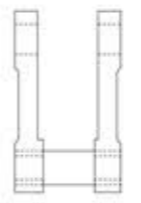

1

注意安装方向
Attention to the correct direction

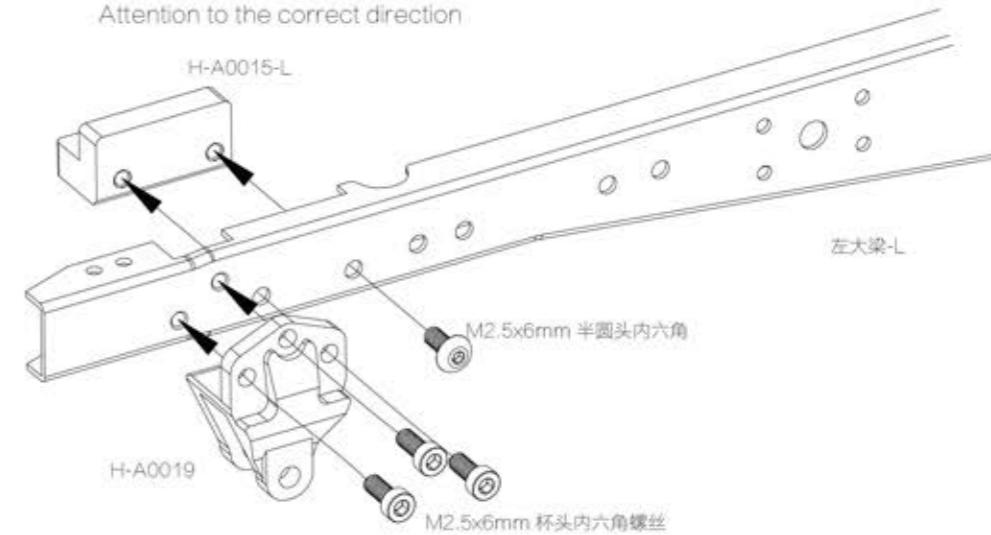

2

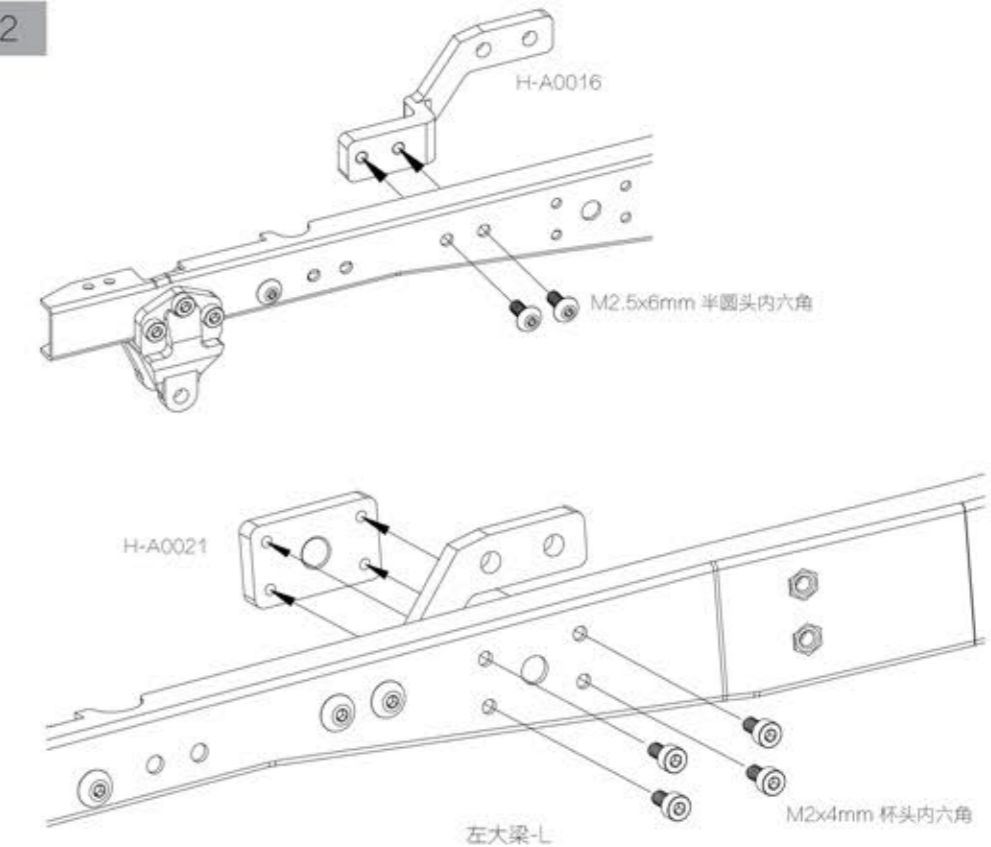

3

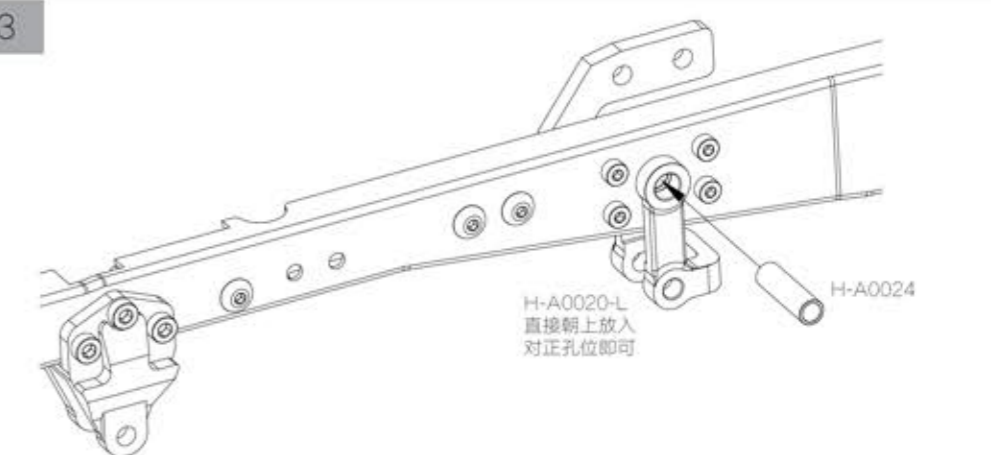

4

- H-A0023 x1
- 2mm 卡簧 x1

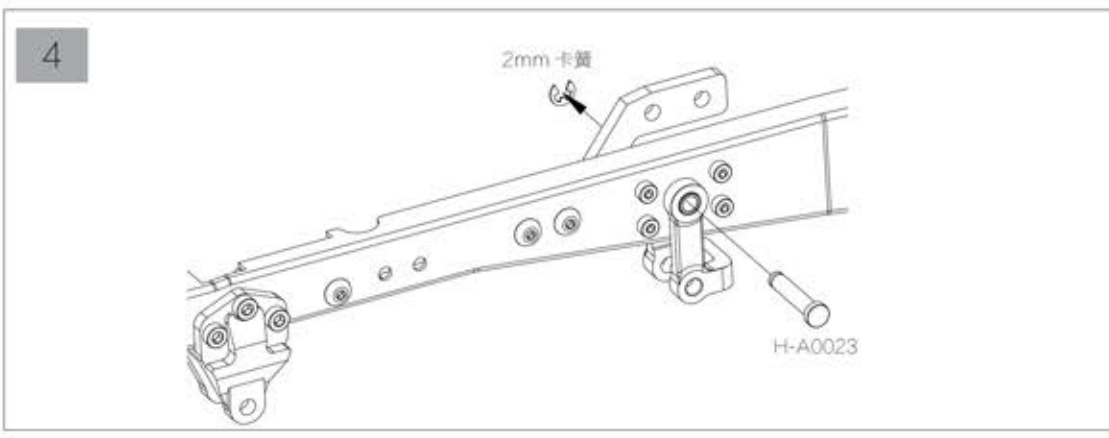

5

- M2x6mm 平头内六角 x4
- M2.5x8mm 半圆头内六角 x2
- M2.5x6mm 半圆头内六角 x2

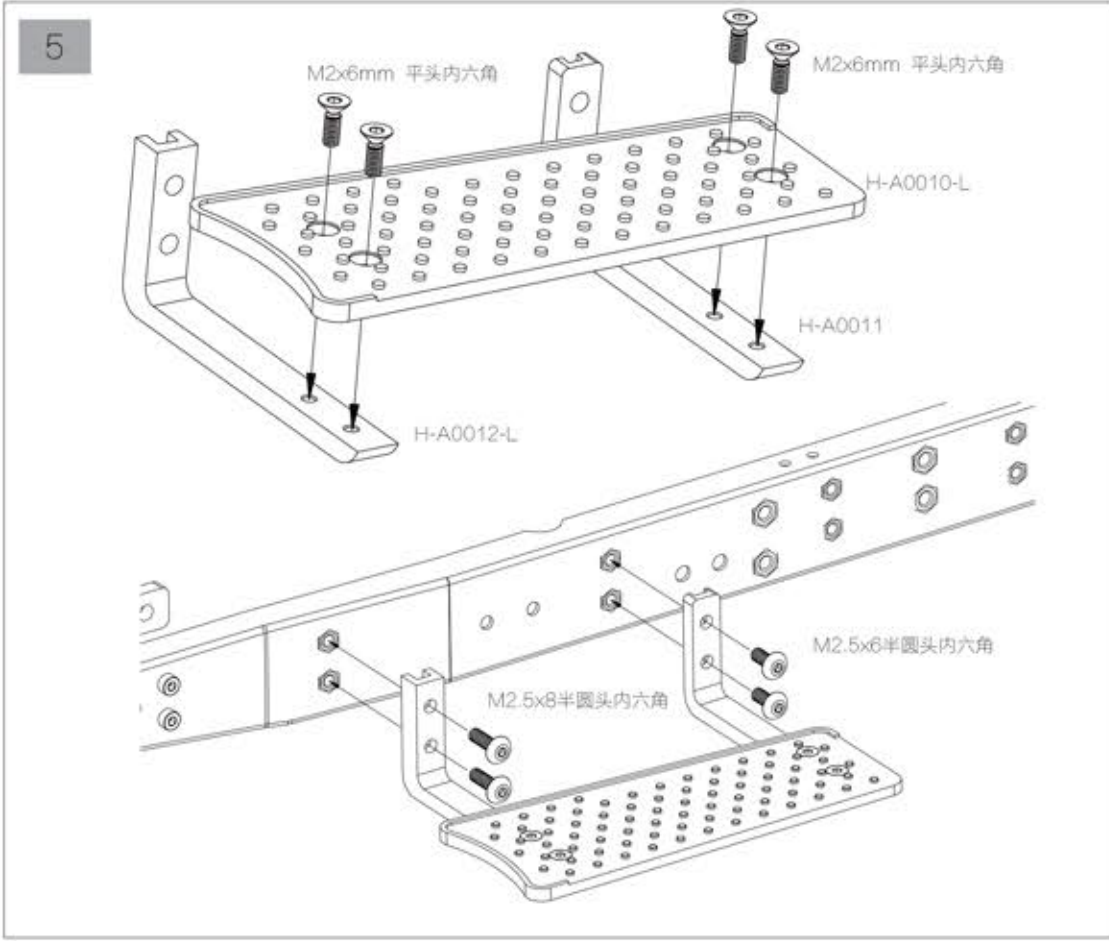

6

- M2.5x8mm 半圆头内六角 x4

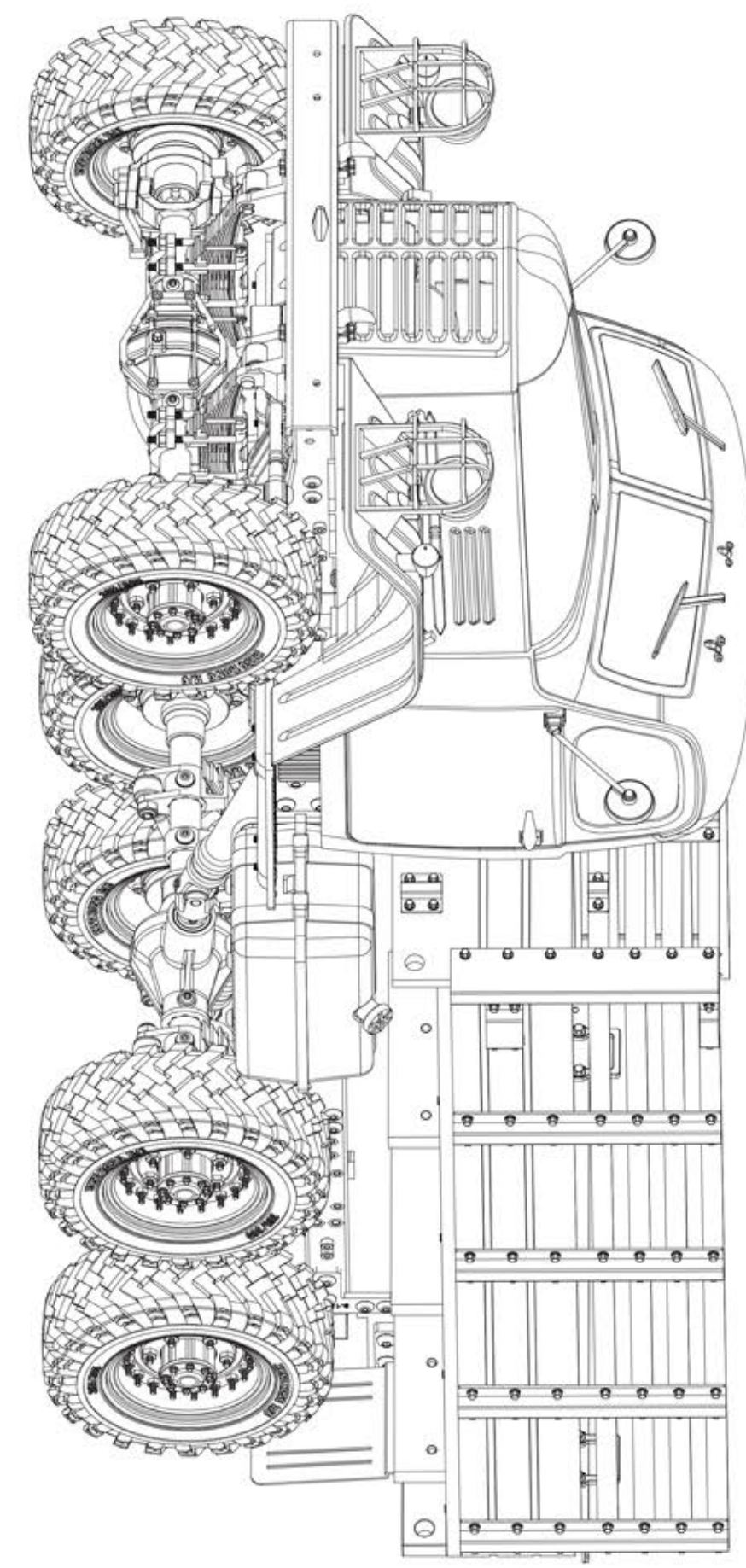
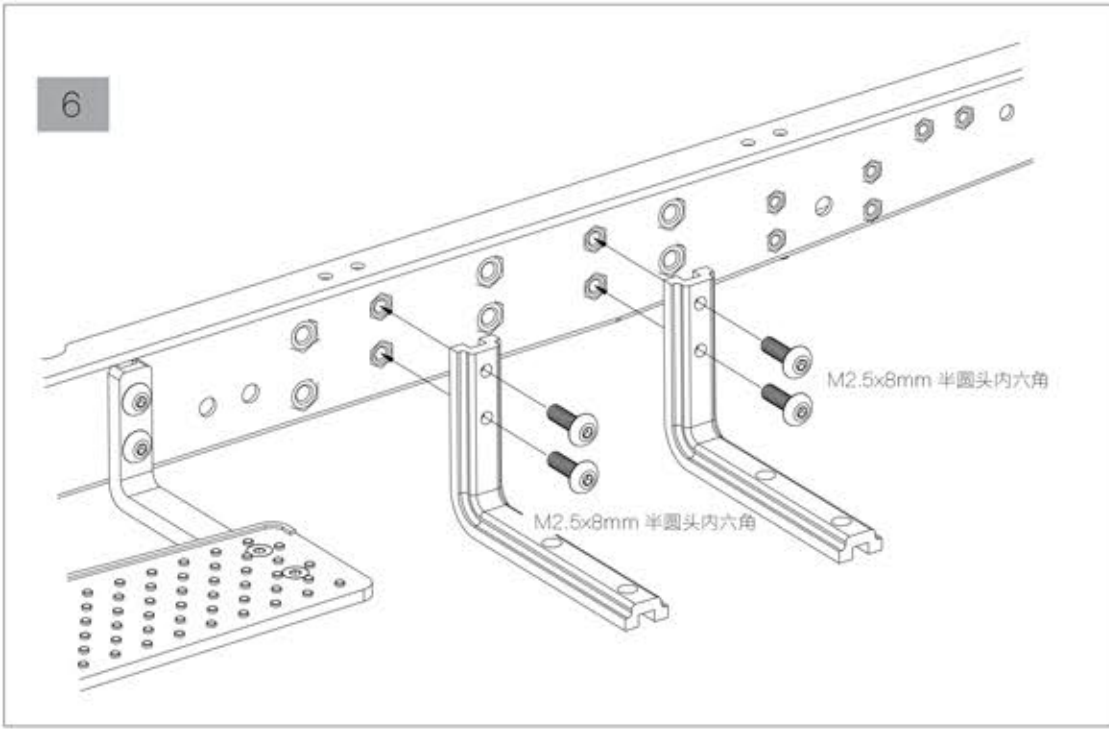

76

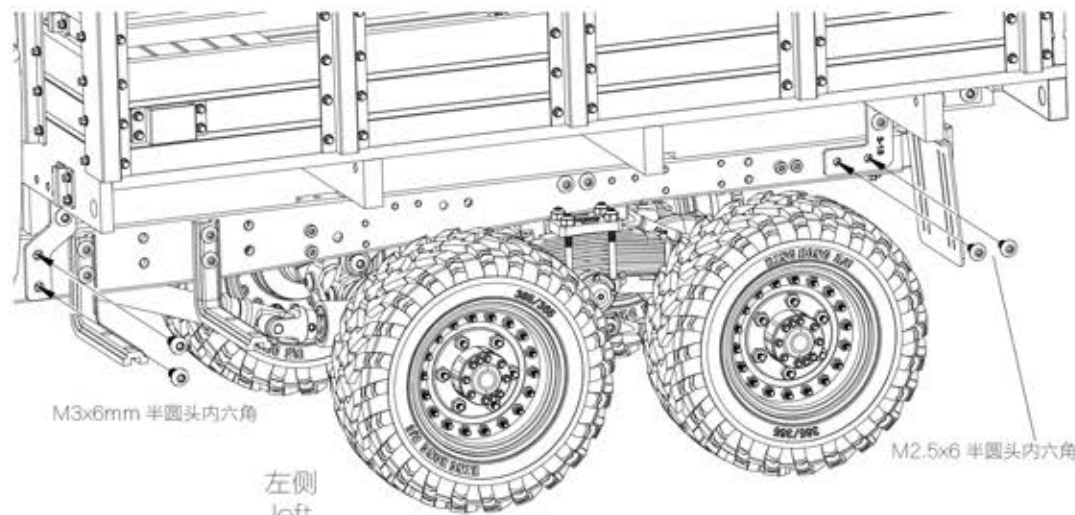

-  M3x6mm 半圆头内六角 x2
-  M2.5x6mm 半圆头内六角 x2

77

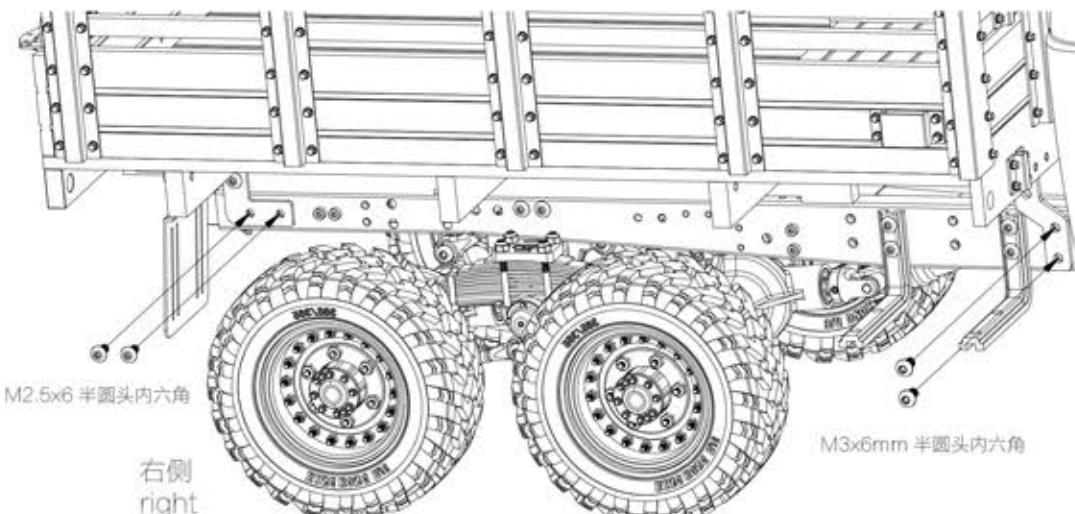

-  M3x6mm 半圆头内六角 x2
-  M2.5x6mm 半圆头内六角 x2

78

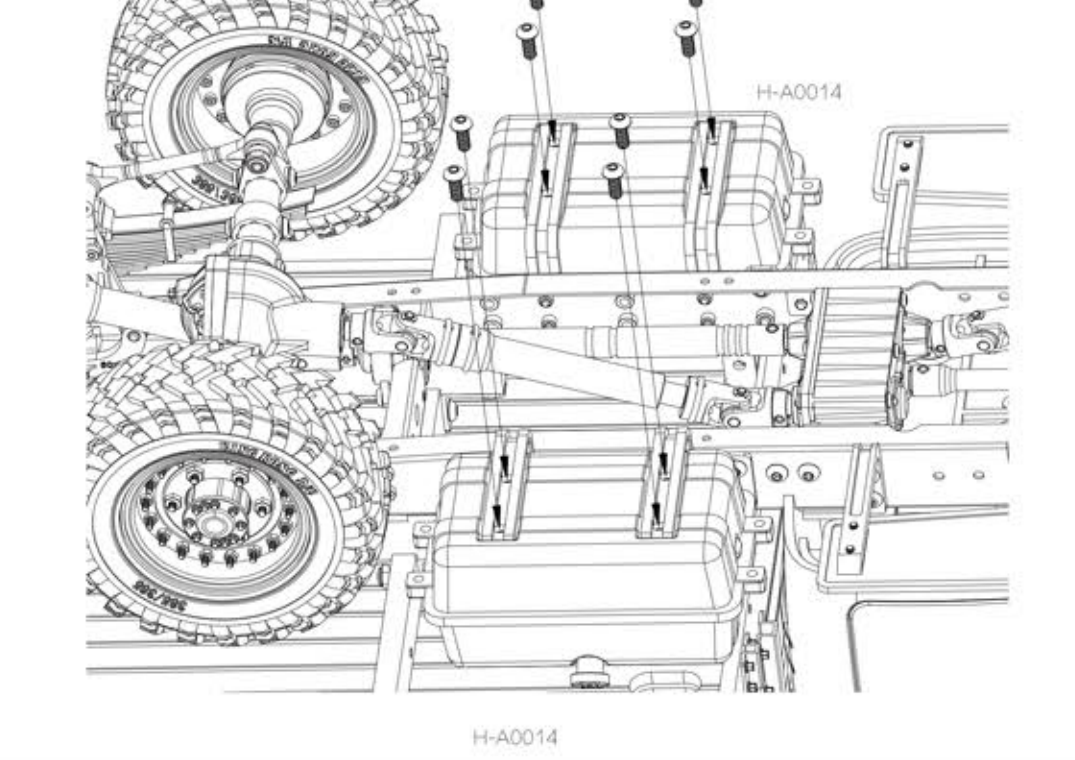

-  M3x8mm 半圆头内六角 x8

7



8



9



10



7

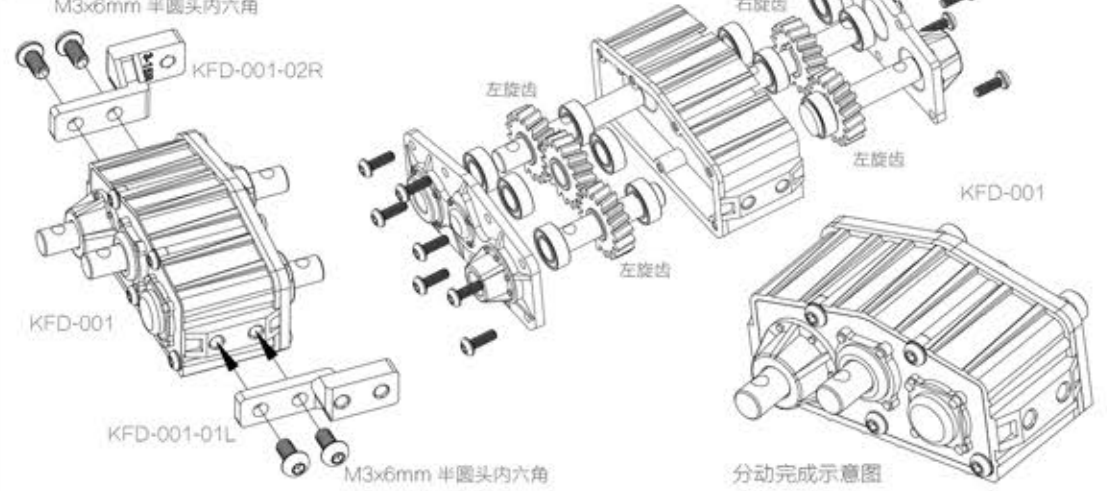

8

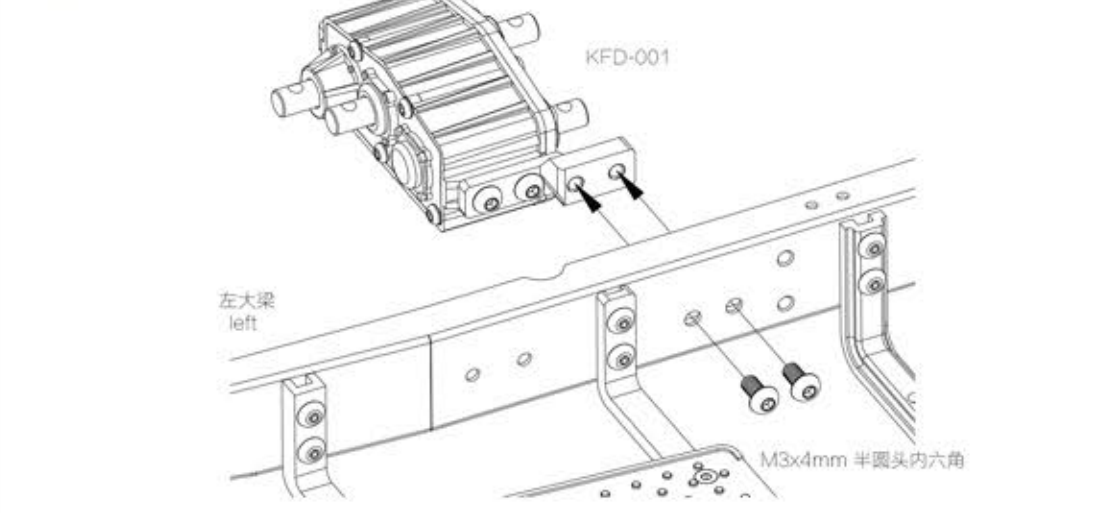

9

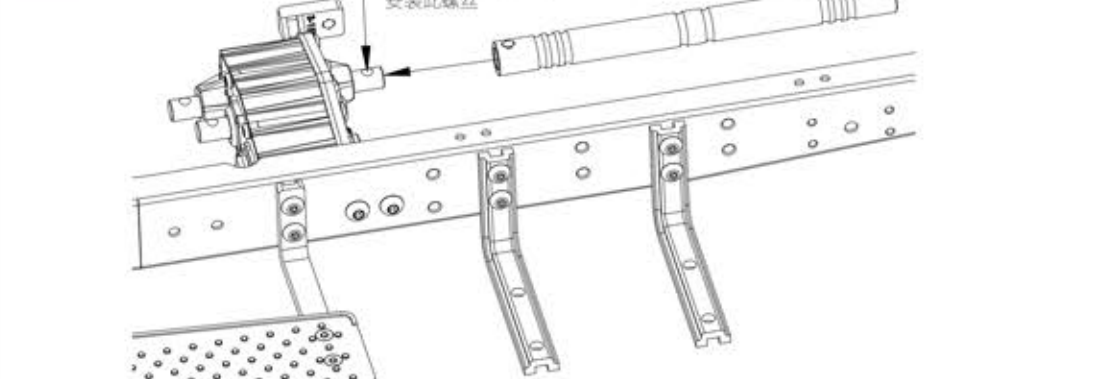

10



11

M3x8mm 机米螺丝
亦可等车架组装完成在
安装此螺丝

KCDZ-005

KDL-001

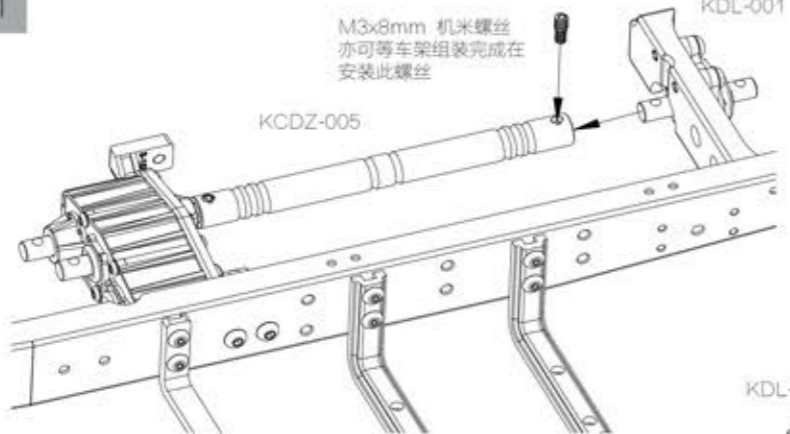

KDL-001

12

M2x6mm 杯头内六角

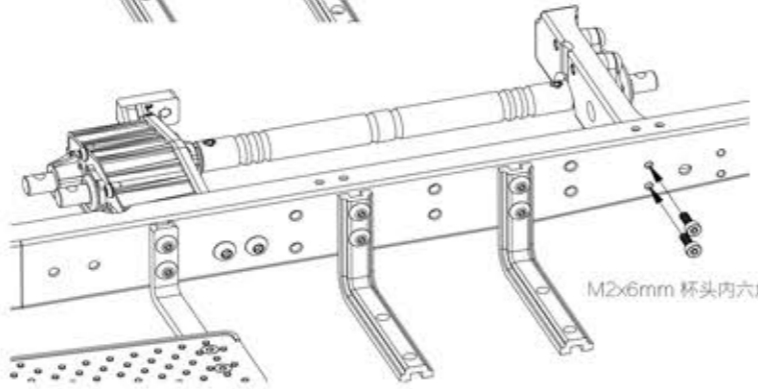

11

M3x8mm 机米螺丝 x1



12

M2x6mm 杯头内六角 x2



13

M2x6mm 杯头内六角 x4

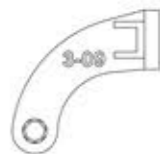

KDL-005 x2

13

M2x6mm 杯头内六角

KDL-005

KDL-002

KDL-005

M2x6mm 杯头内六角

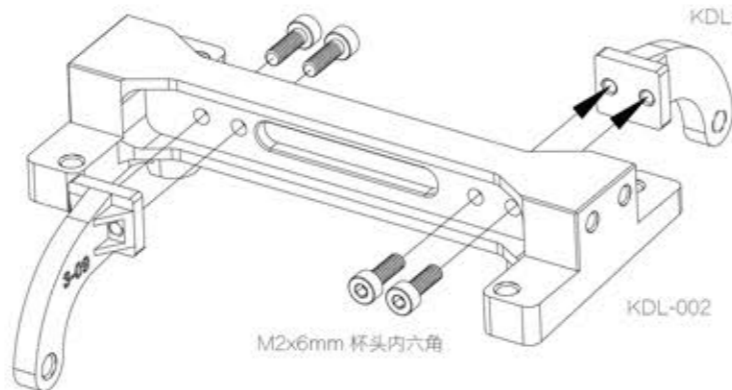

14

M2.5x6mm半圆头内六角 x2



14

KDL-002

M2.5x6mm半圆头内六角

左大梁
left

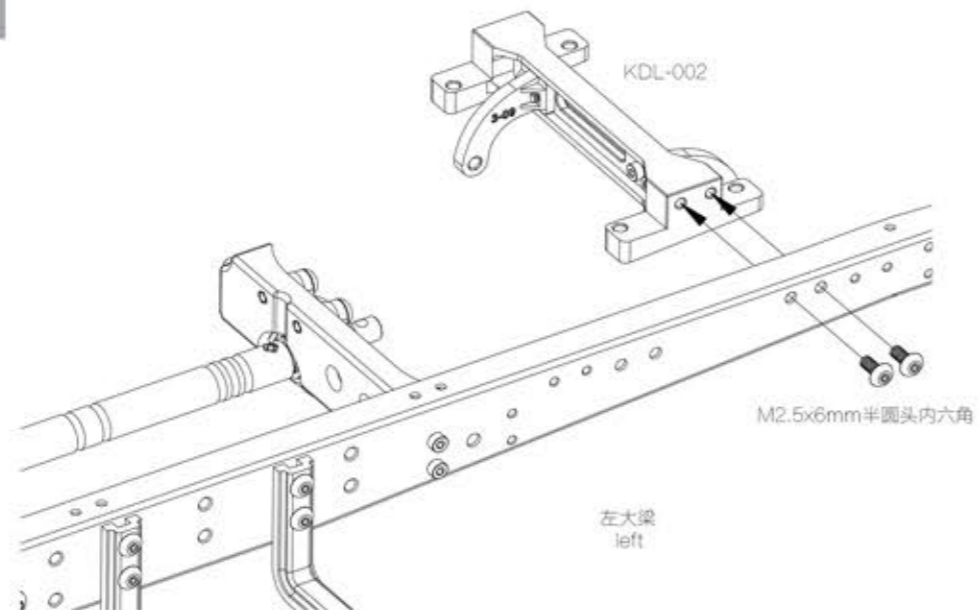

73

M3x6mm 半圆头内六角 x2



H-D001-001 x2



74

M3x6mm 半圆头内六角 x2



H-D001-001 x2



73

M3x6mm 半圆头内六角

H-D001-001

M3x6mm 半圆头内六角

H-D001-001

左侧
left

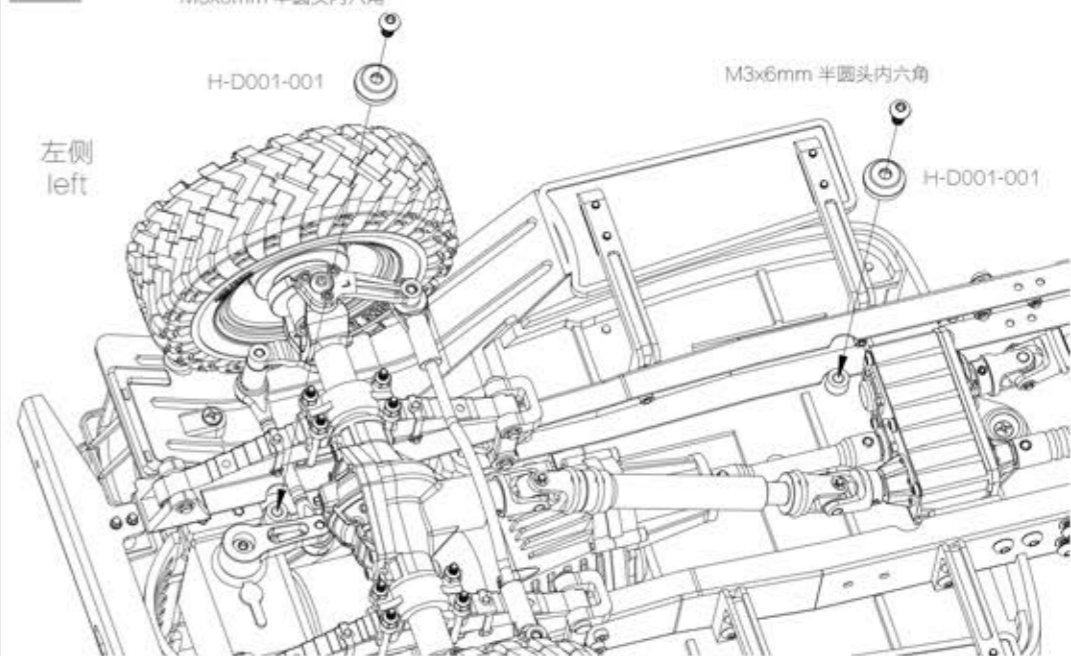

74

M3x6mm 半圆头内六角

H-D001-001

M3x6mm 半圆头内六角

H-D001-001

右侧
right

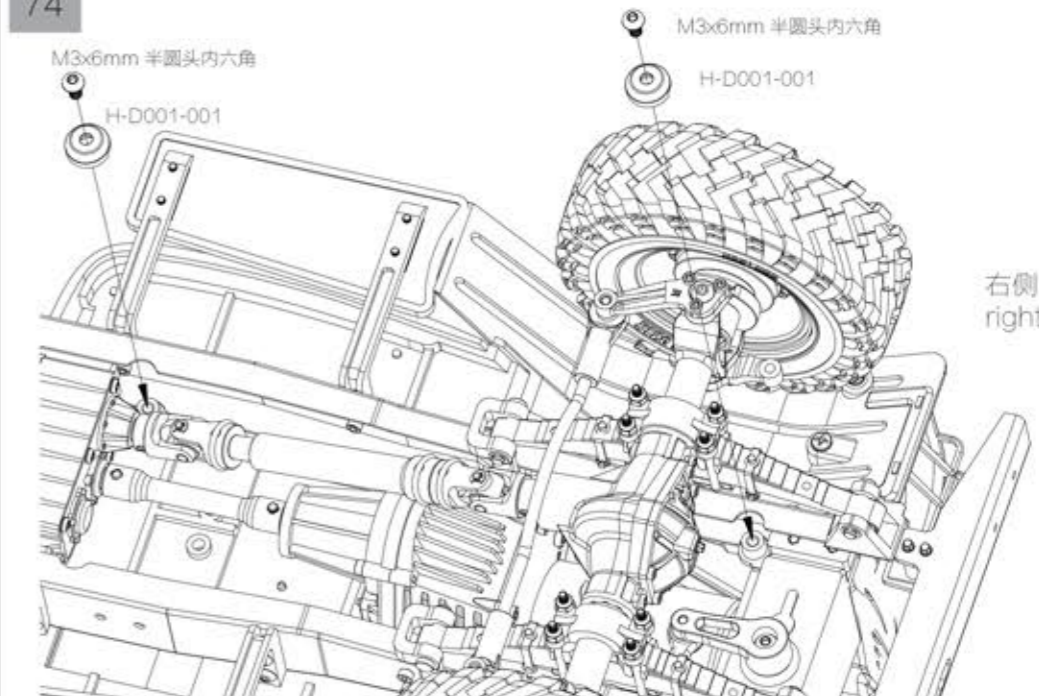

75

车斗需参考其单独包装内说明书进行安装
View the Body Assembly Manual before start.

75

KCD-003

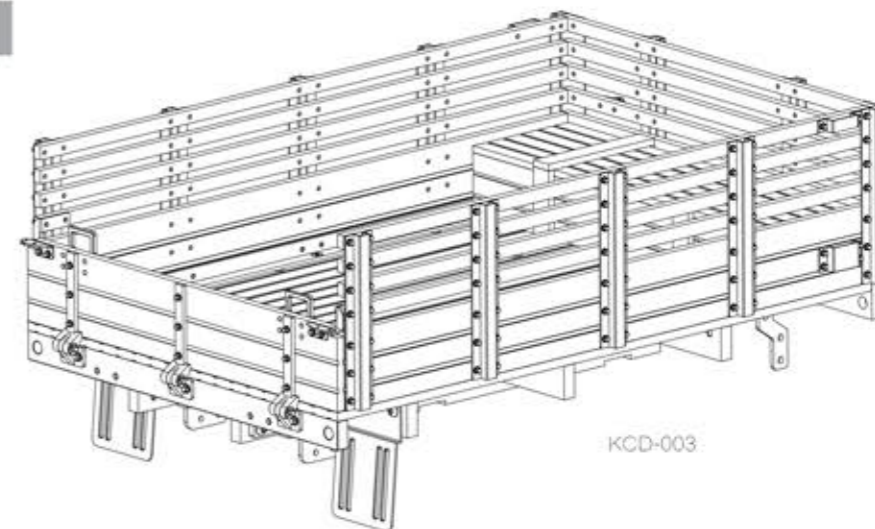

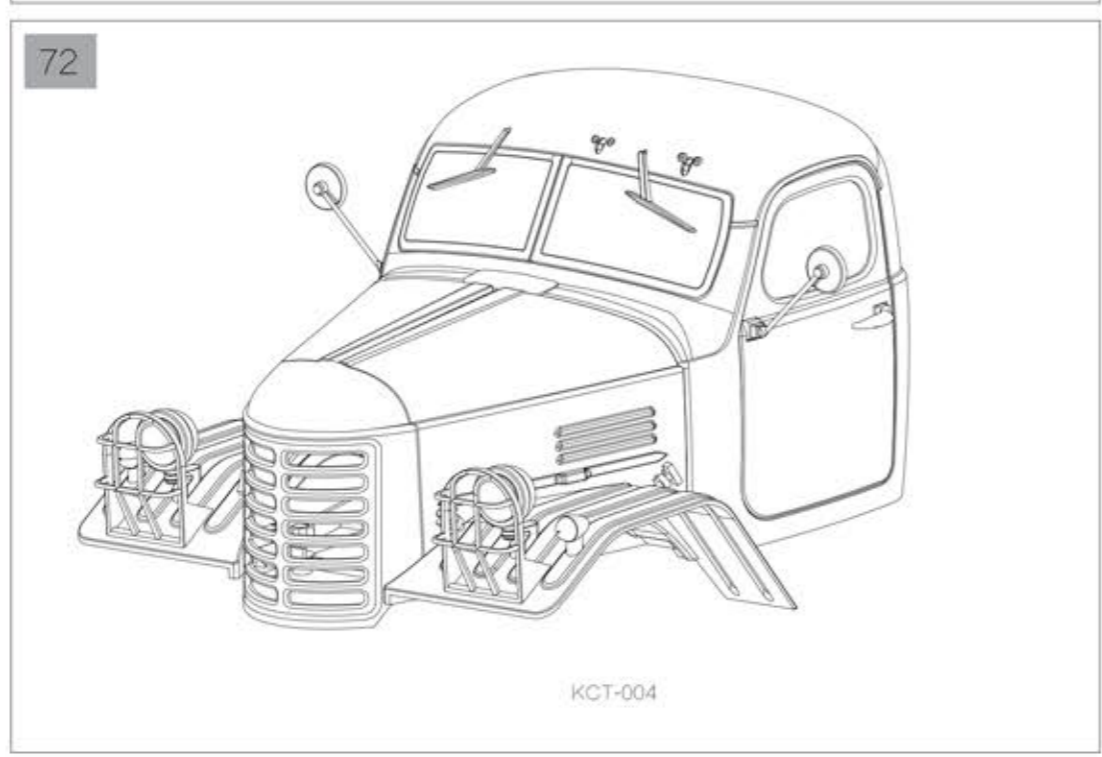
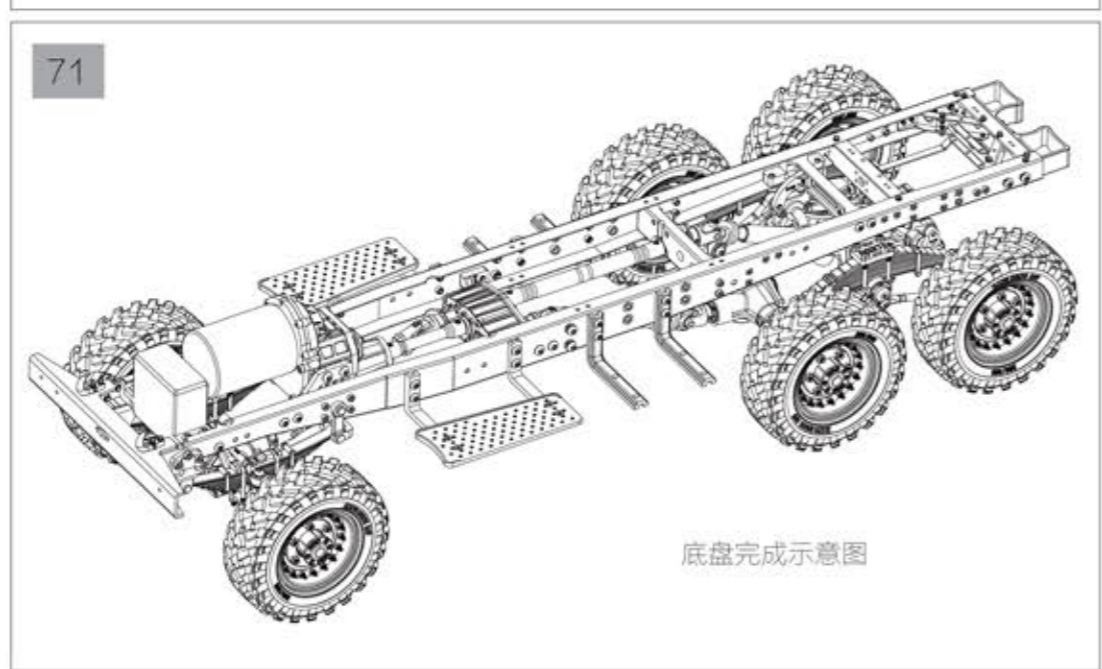
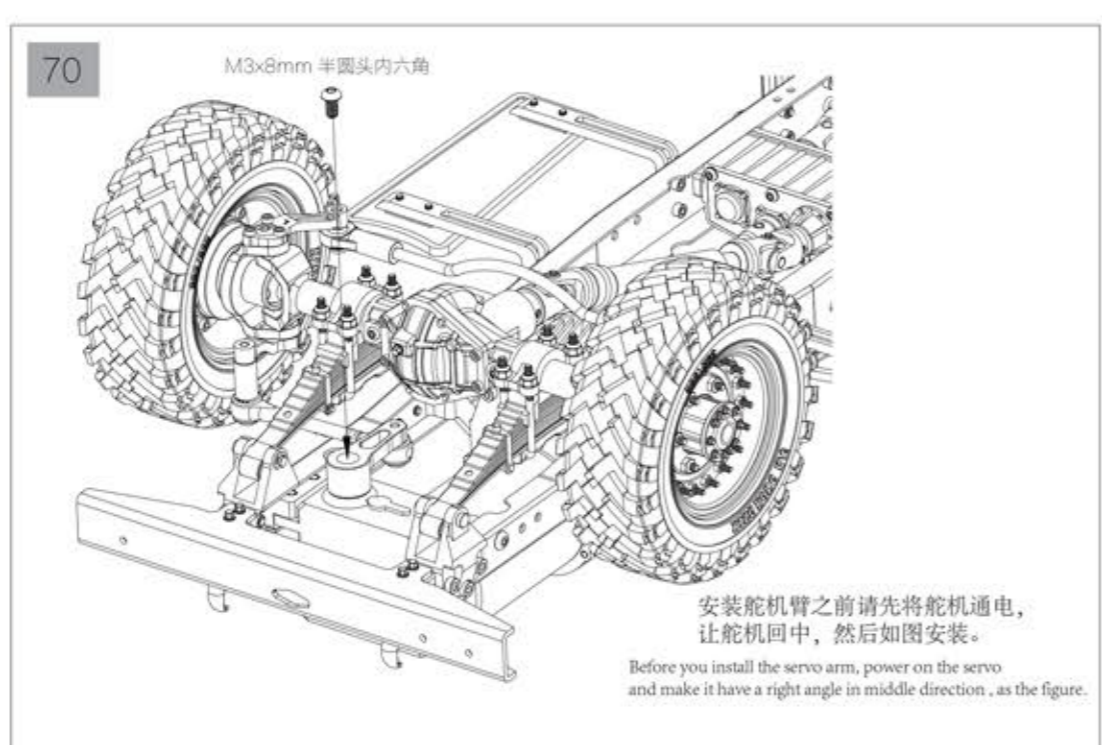
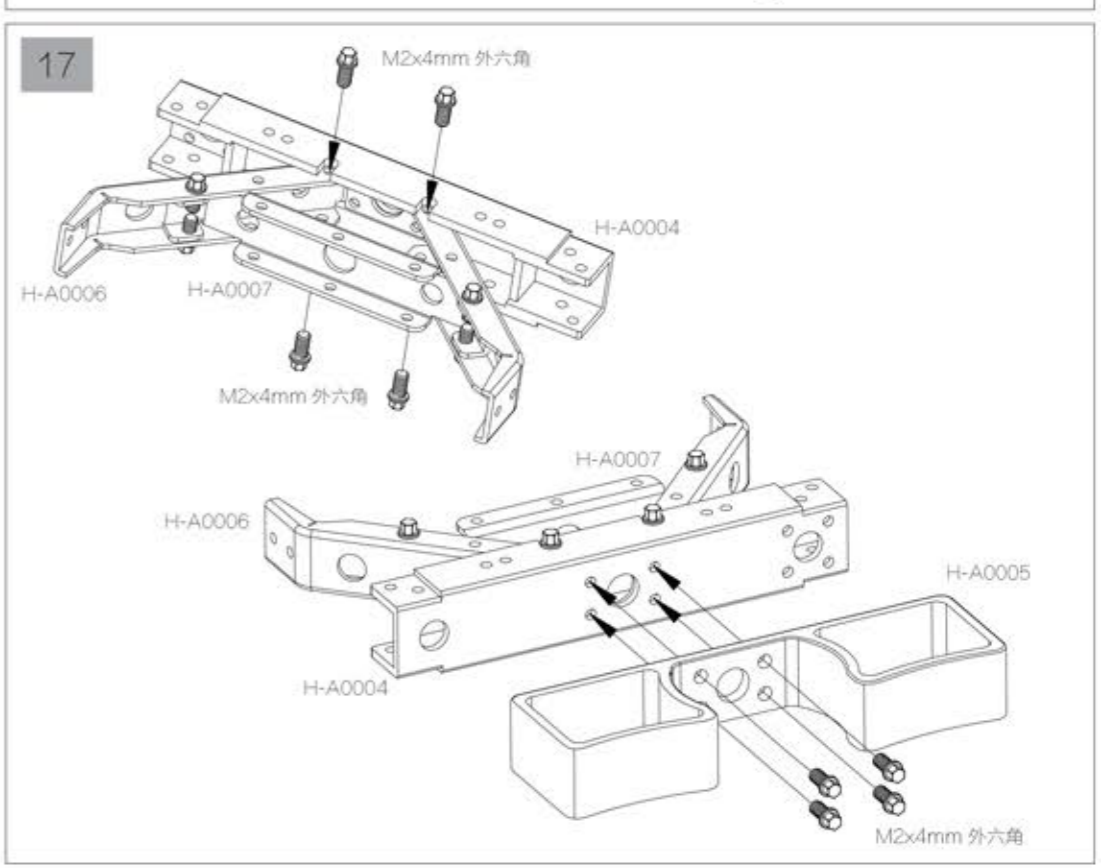
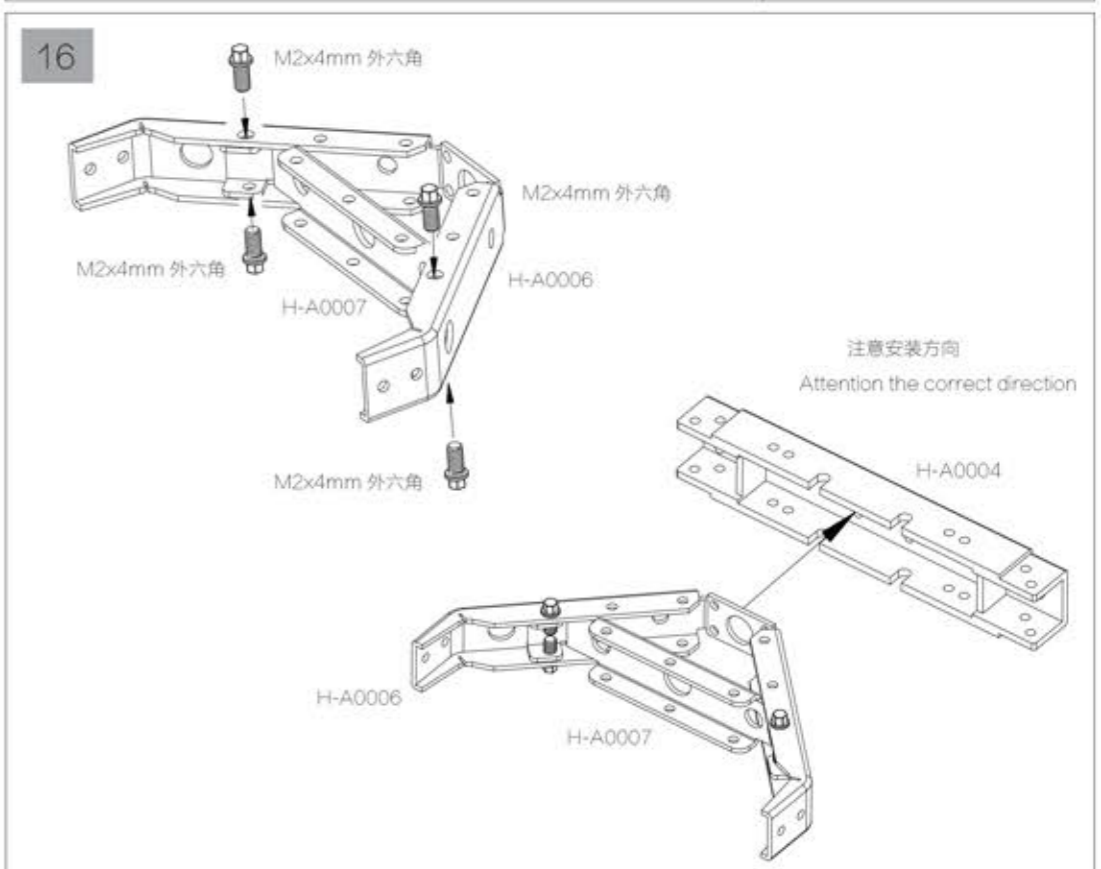
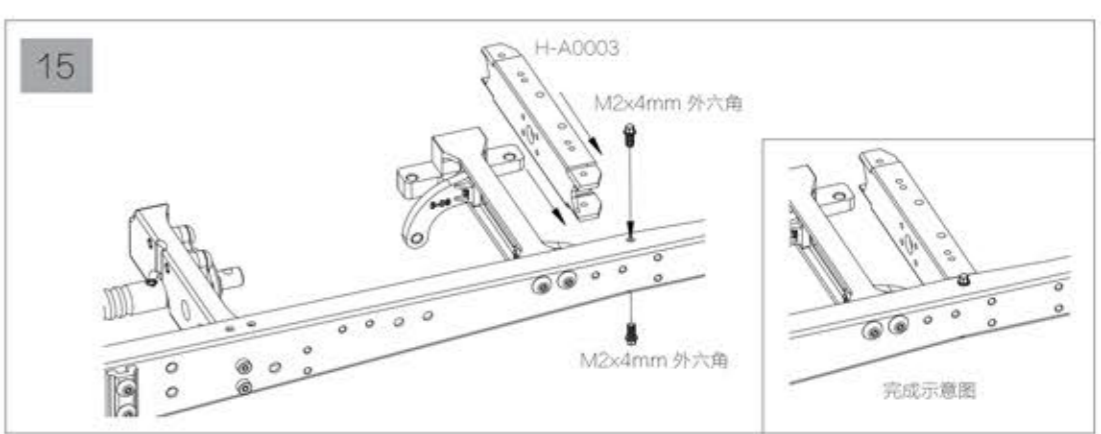

70

M3x8mm 半圆头内六角 x1

71

底盘完成示意图

72

车壳需参考其单独包装内说明书进行安装
View the Body Assembly Manual before start.

15

M2x4mm 外六角 x2

16

M2x4mm 外六角 x4

17

M2x4mm 外六角 x8

18

- M2x4mm 外六角 x 4
- M2x4mm 杯头内六角 x 2

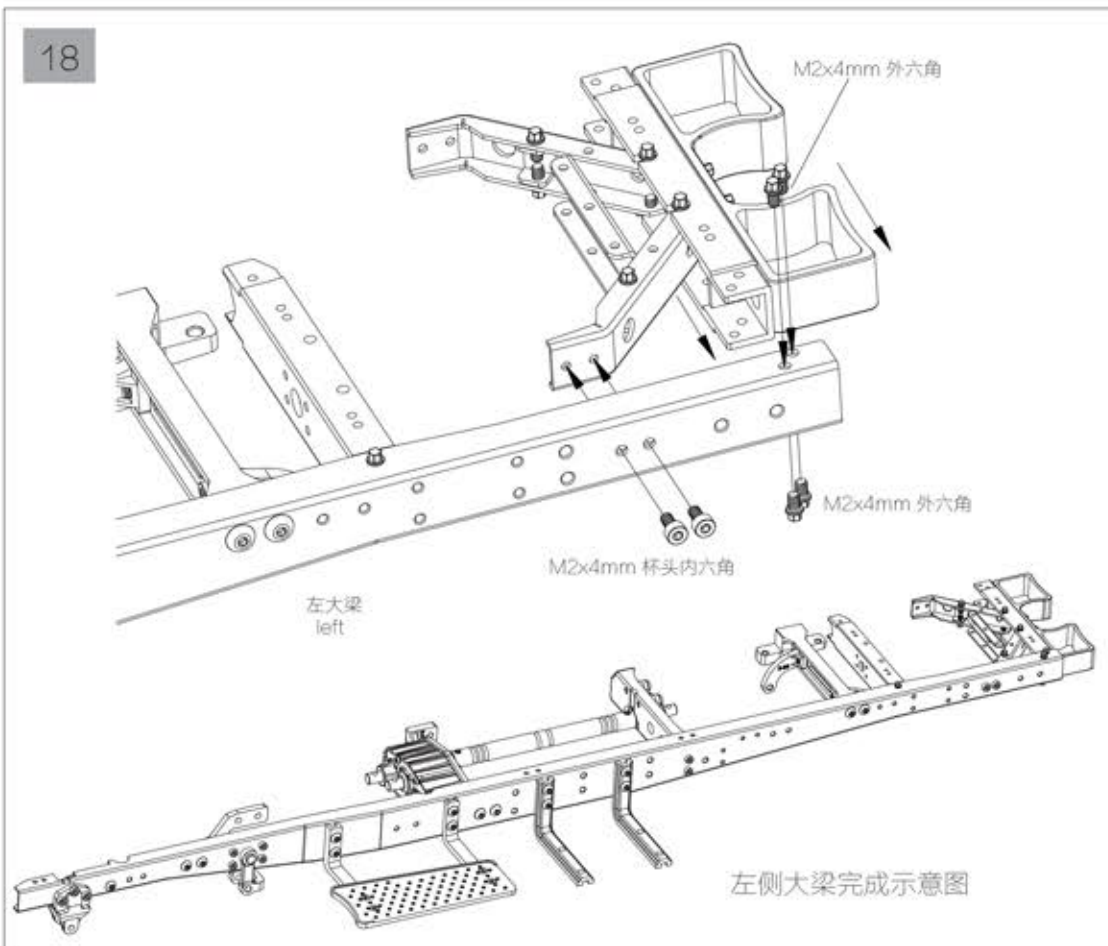

19

- M2.5x6mm 杯头内六角 x 3
- M2.5x6mm 半圆头内六角 x 1

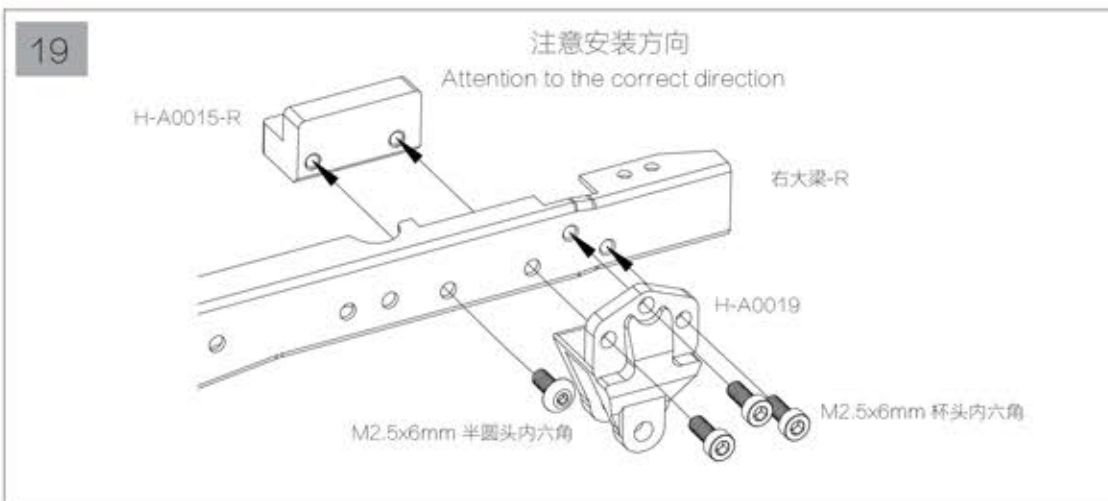

20

- M2x4mm 杯头内六角 x 4
- H-A0021

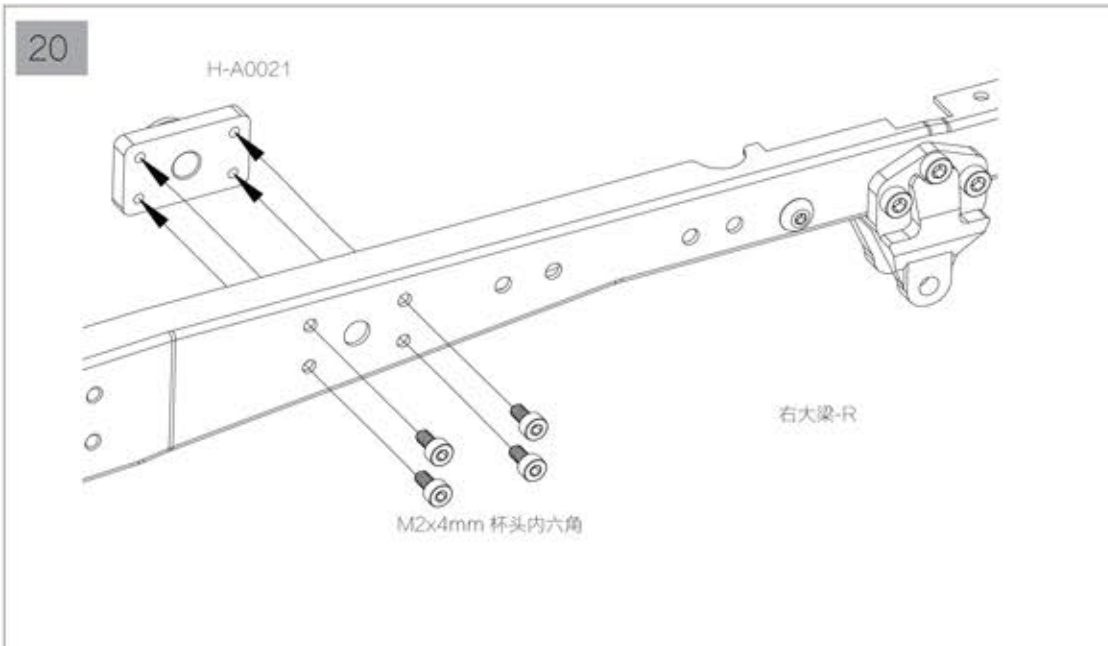

67

- M3x8mm 半圆头内六角 x 4

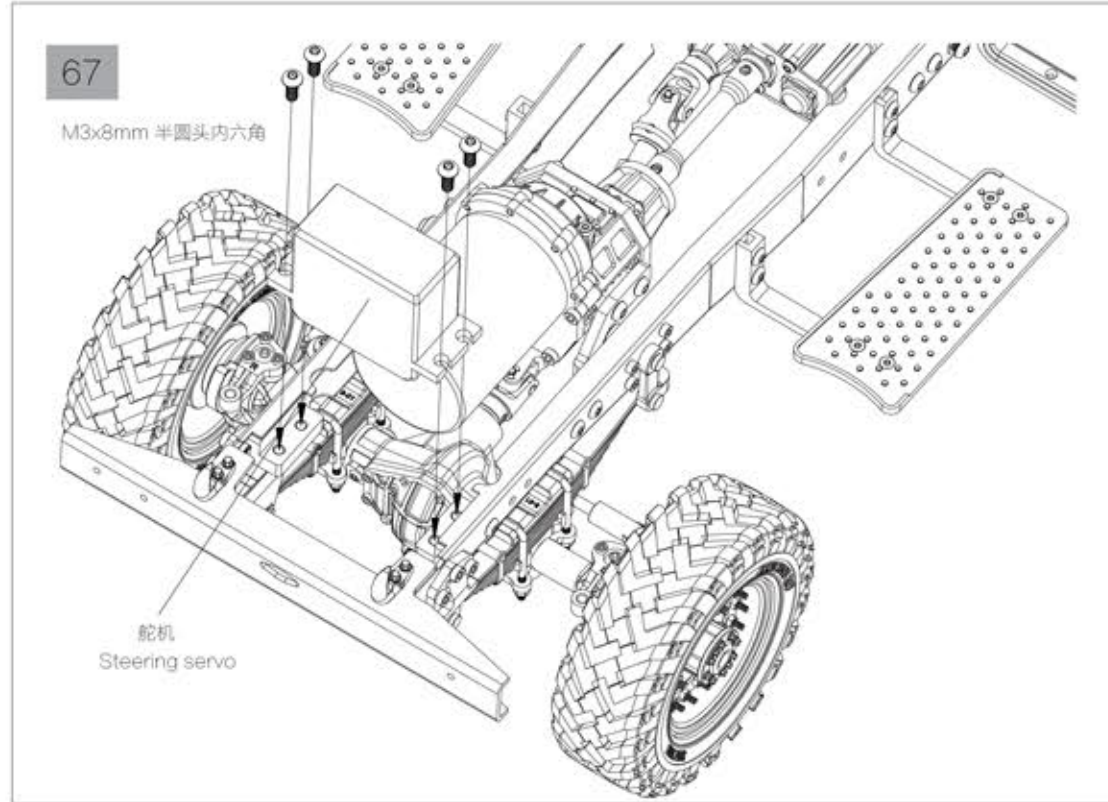

68

- M3x10mm 半圆头内六角 x 1

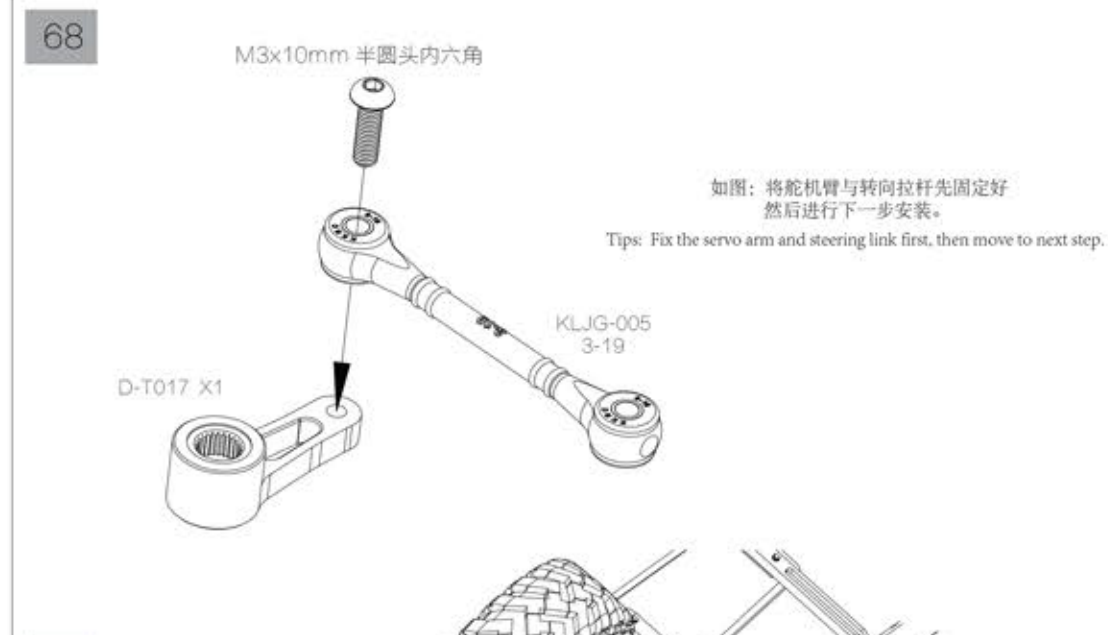

69

- M3x22mm 半圆头内六角 x 1
- 6x11.2mm 圆柱垫片 x 1 KLJG-006

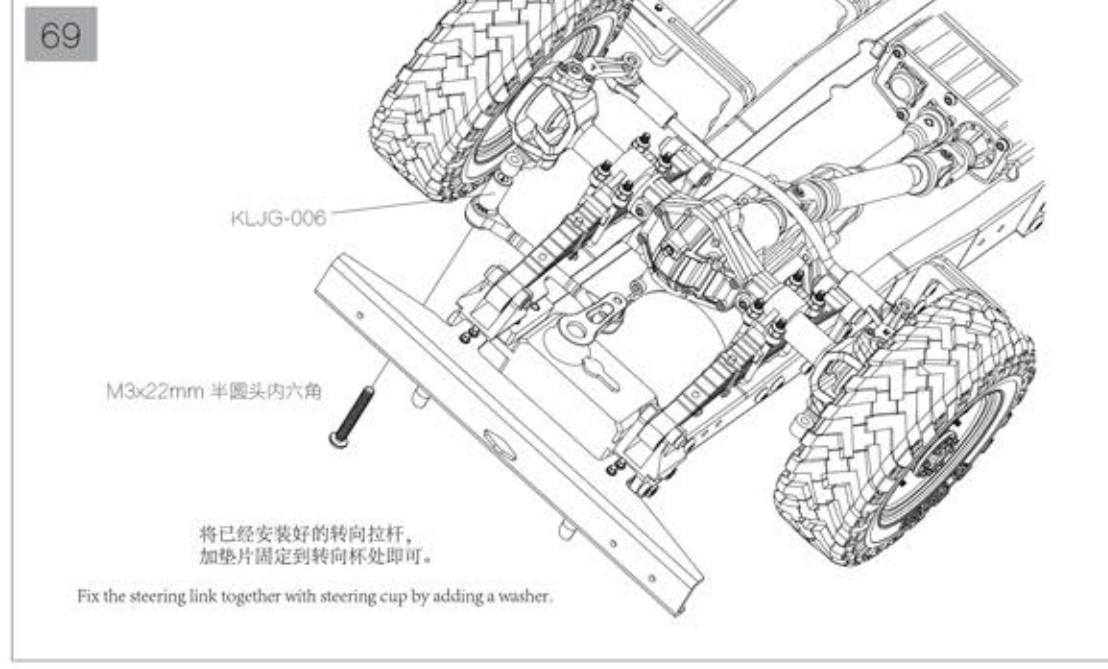

64



M2 螺母 x 12

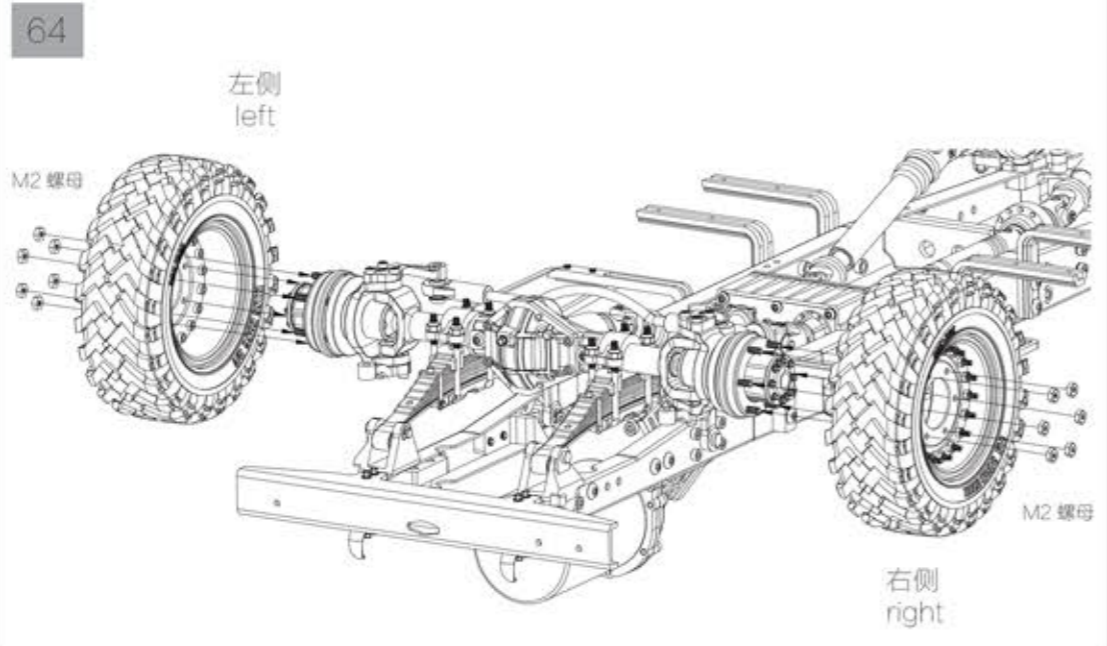

65



M2 螺母 x 12

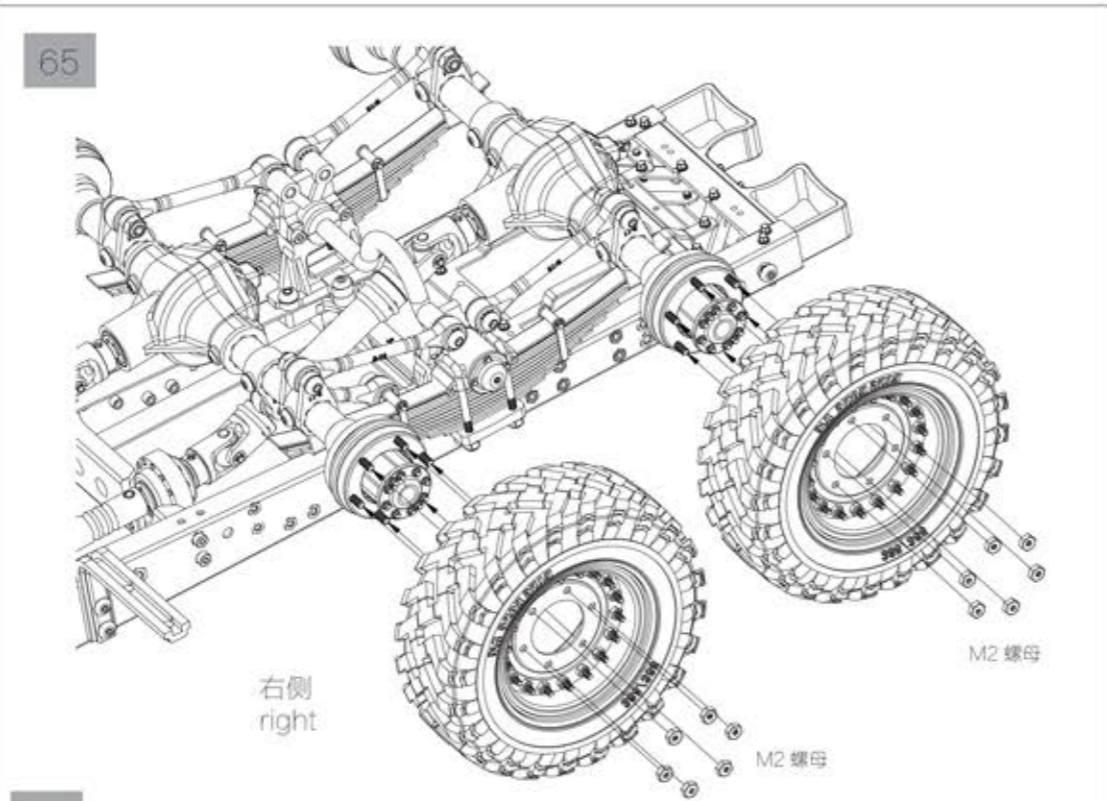

66



M2 螺母 x 12

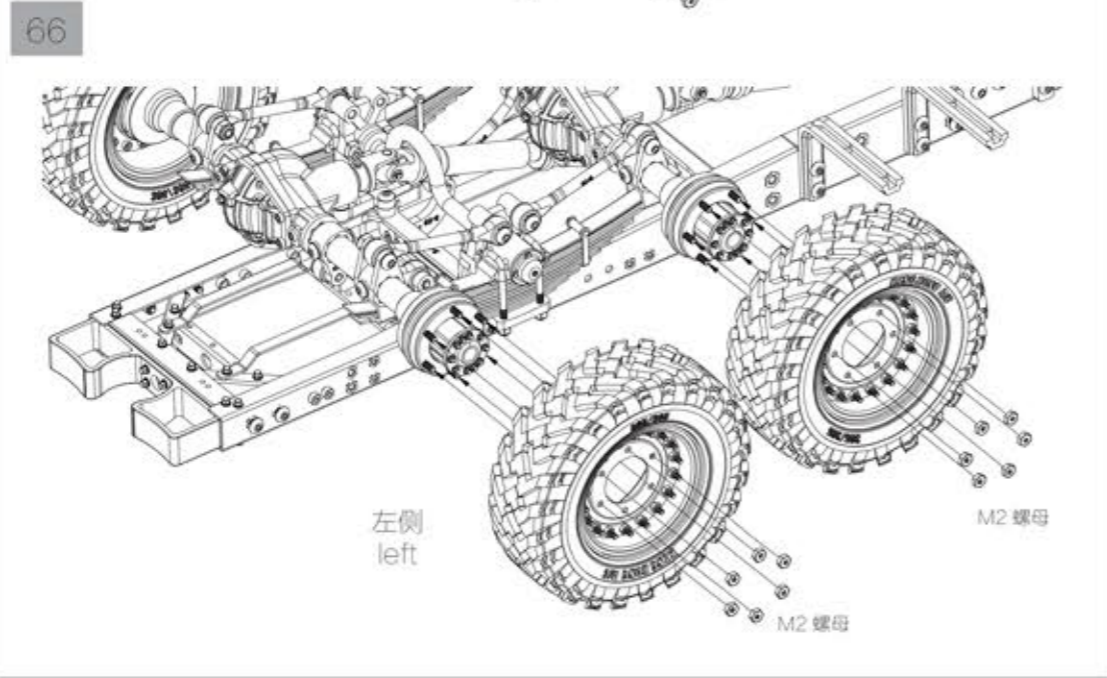

21

21

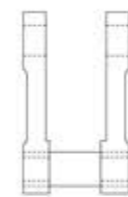

H-A0020-R x 1



H-A0024 x 1



H-A0023 x 1



2mm 卡簧 x 1

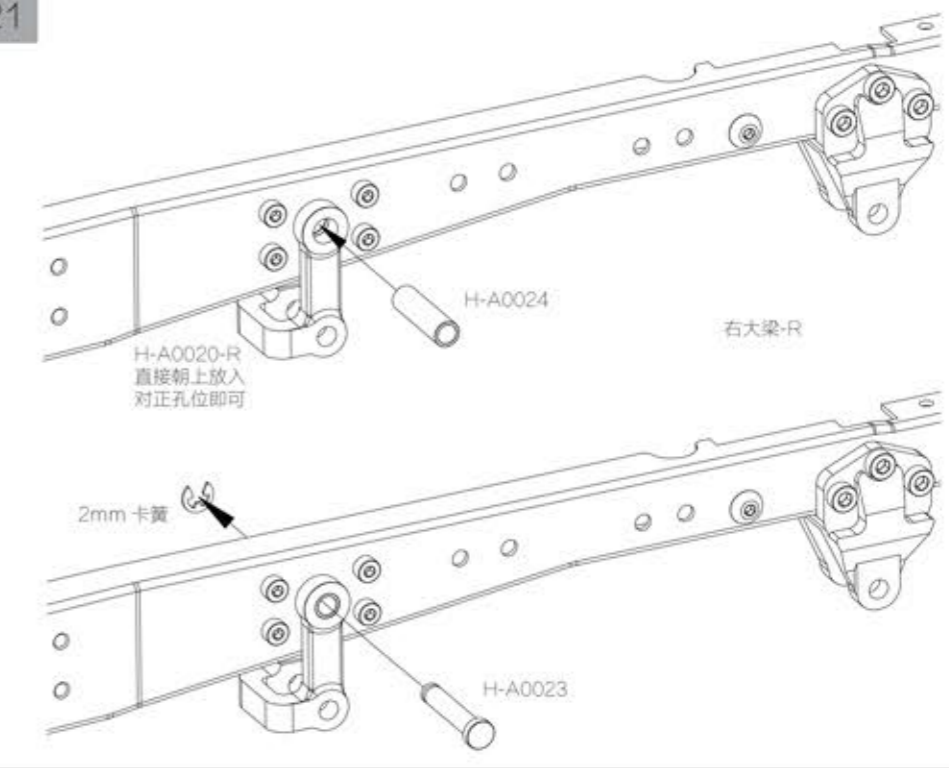

22



M2x6mm 平头内六角 x 4



M2.5x6mm 半圆头内六角 x 2



M2.5x8mm 半圆头内六角 x 2

22

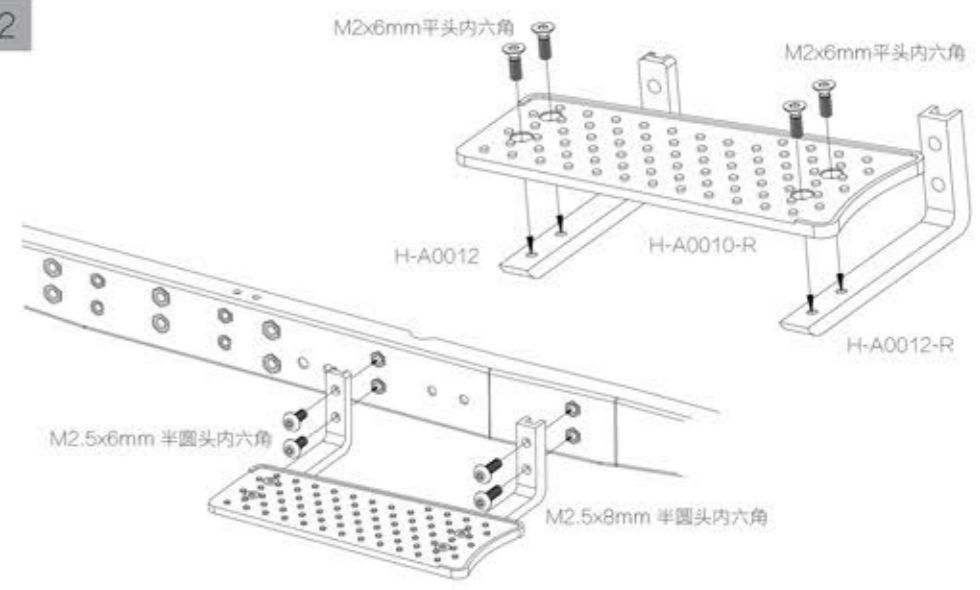

23



M2.5x8mm 半圆头内六角 x 4

23

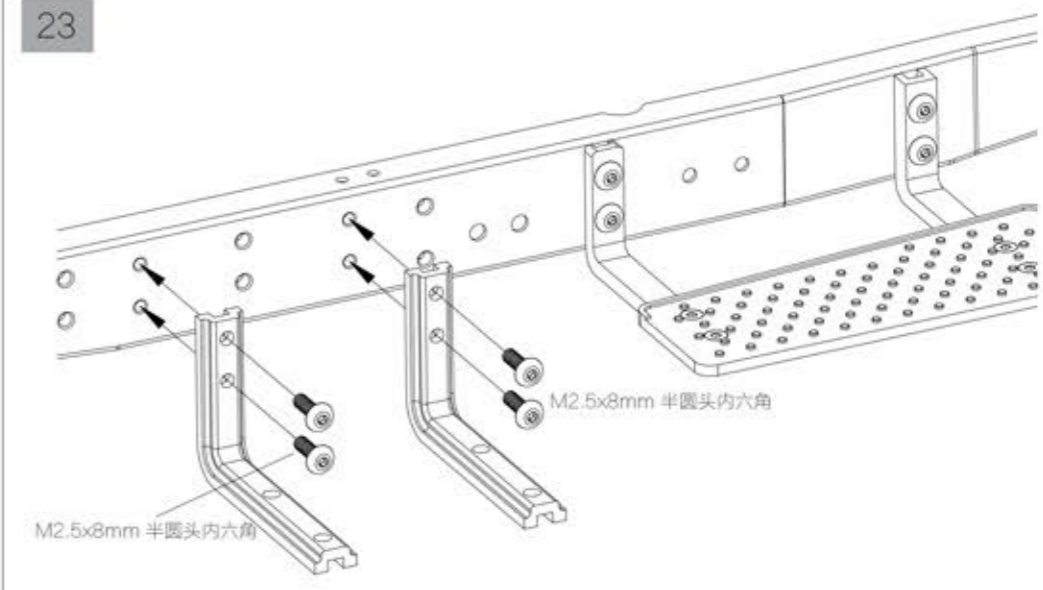

24

-  M2x4mm 杯头内六角 x2
-  M2.5x6mm 半圆头内六角 x2
-  M2x6mm 杯头内六角 x2
-  M3x4mm 半圆头内六角 x2

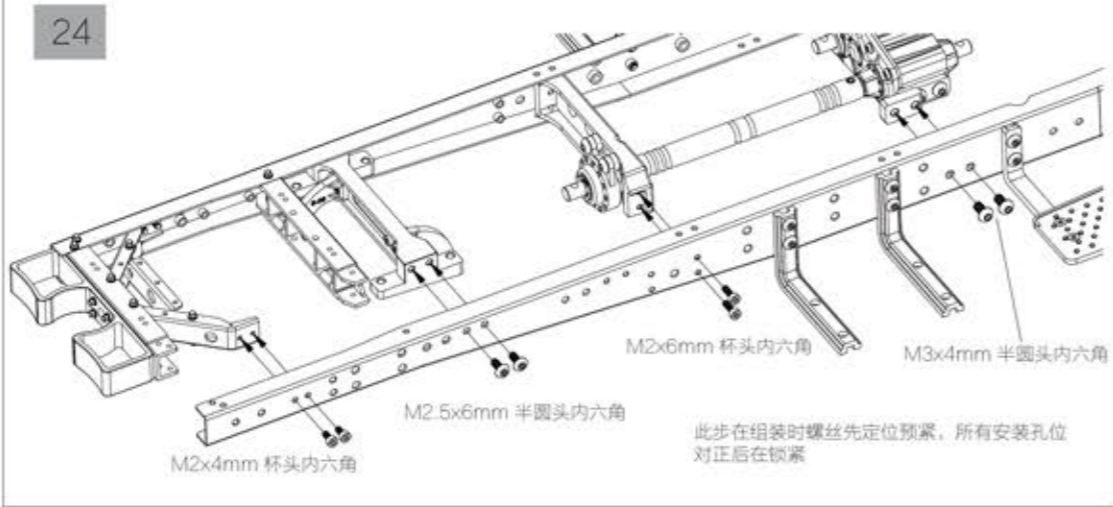

25

-  M2x4mm 外六角 x6

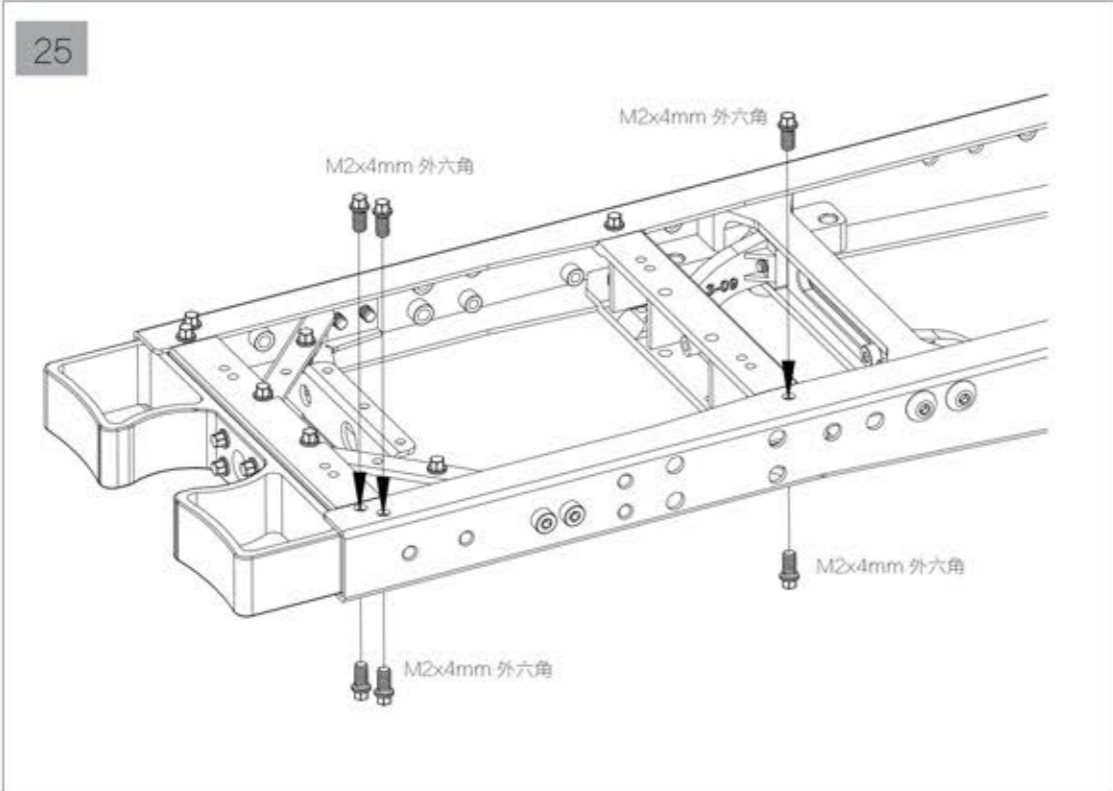

26

-  M2x4mm 外六角 x4

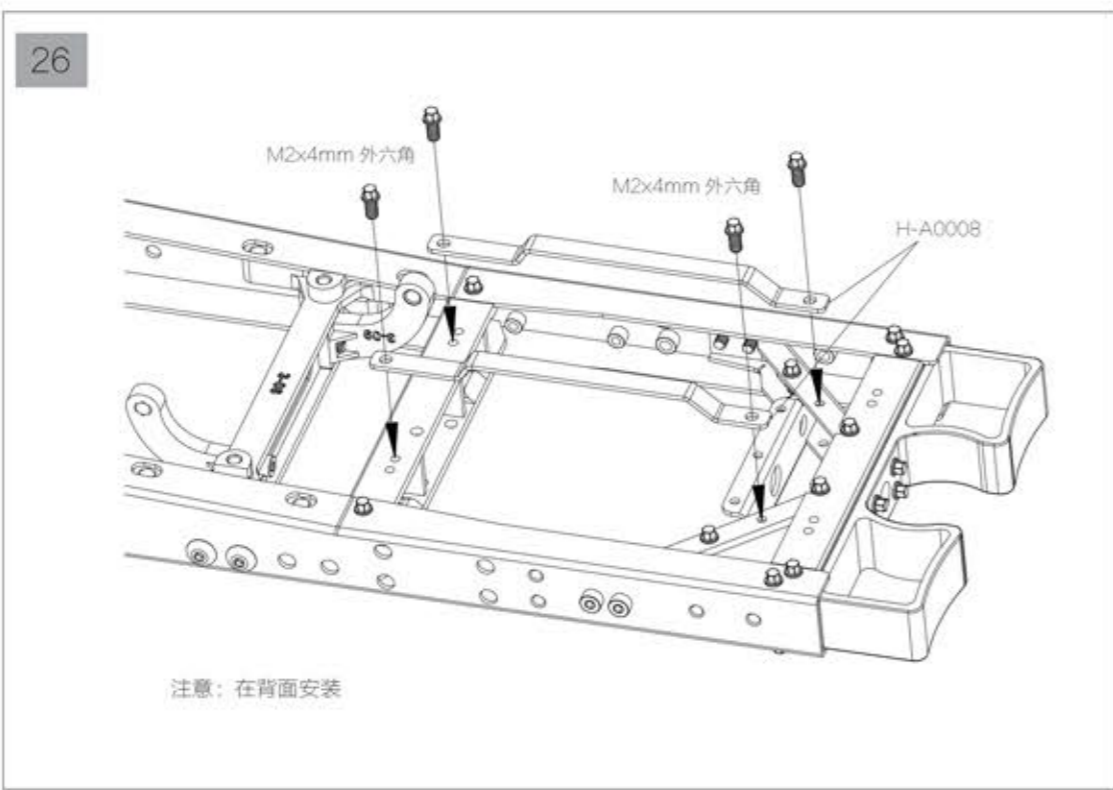

61

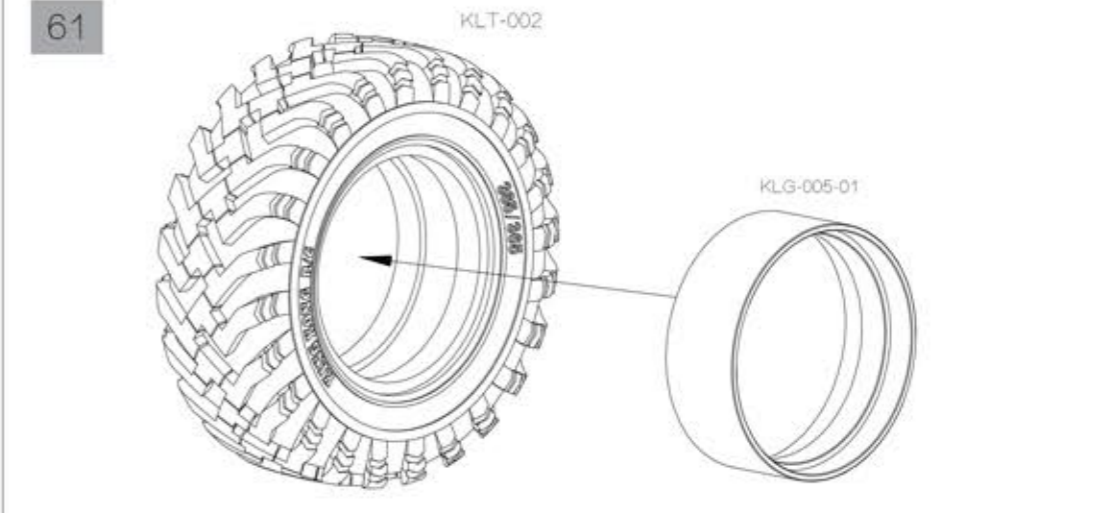

62

-  M1.6x6mm 杯头内六角 x108
-  M1.6螺母 x108

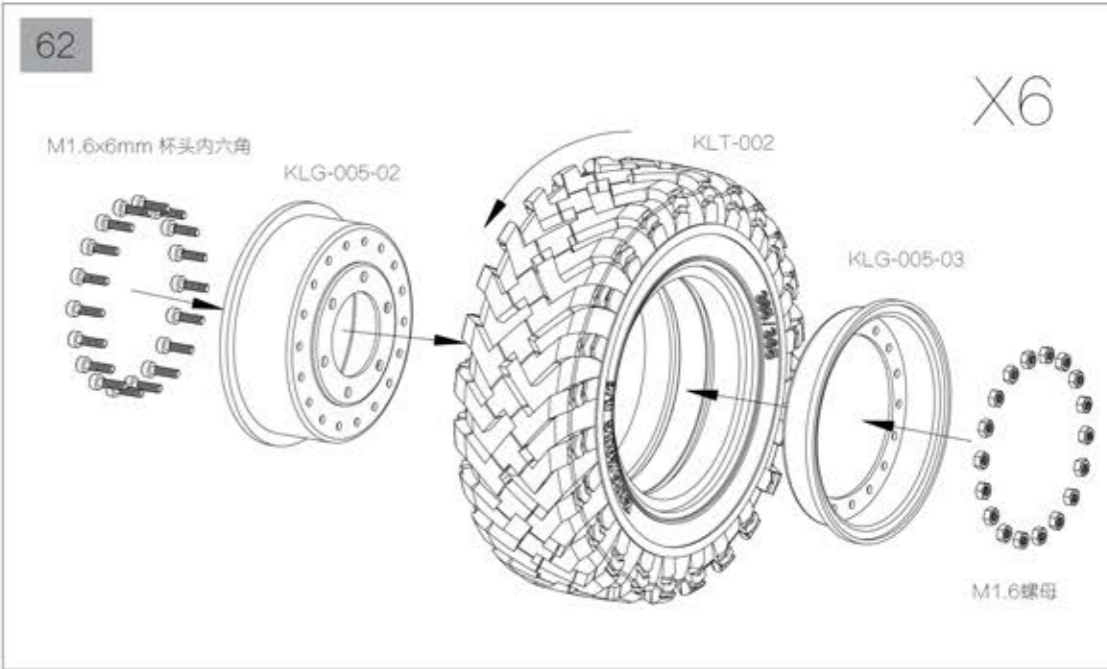

63

轮毂完成示意图

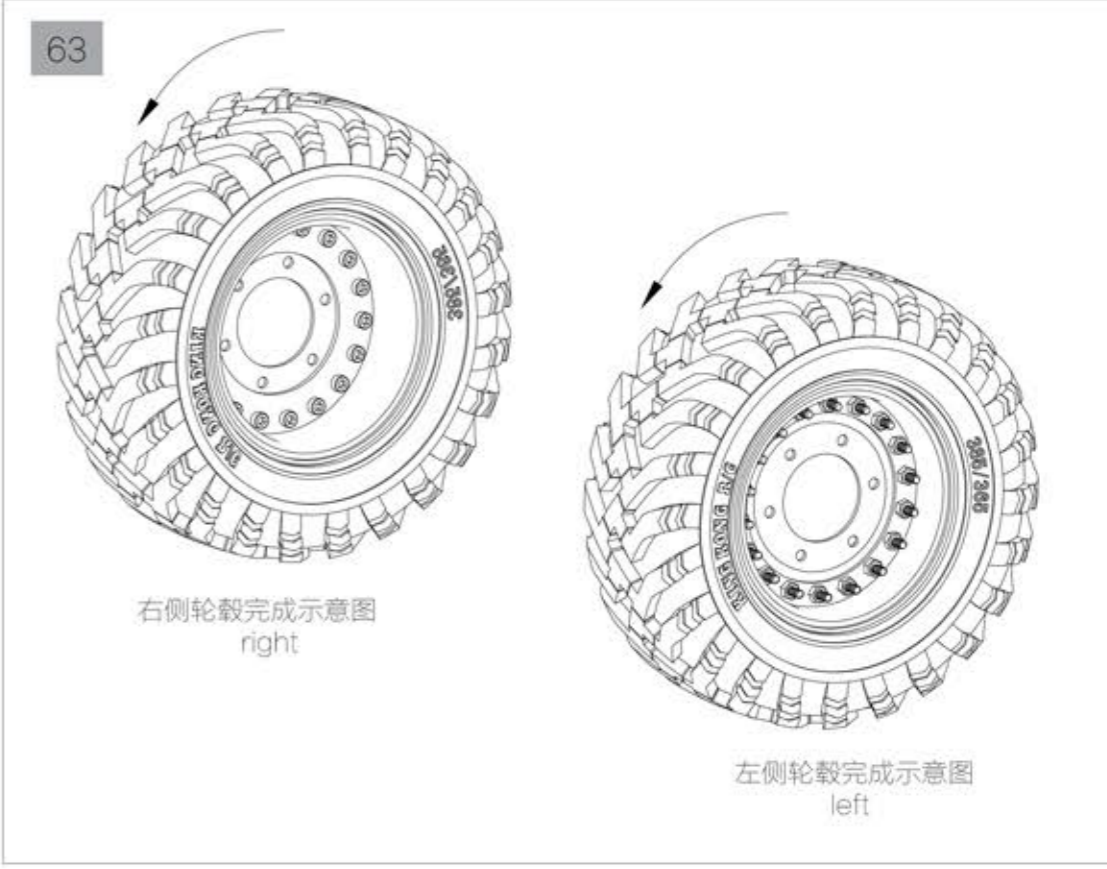

58

M3x8mm 机米螺丝 x1

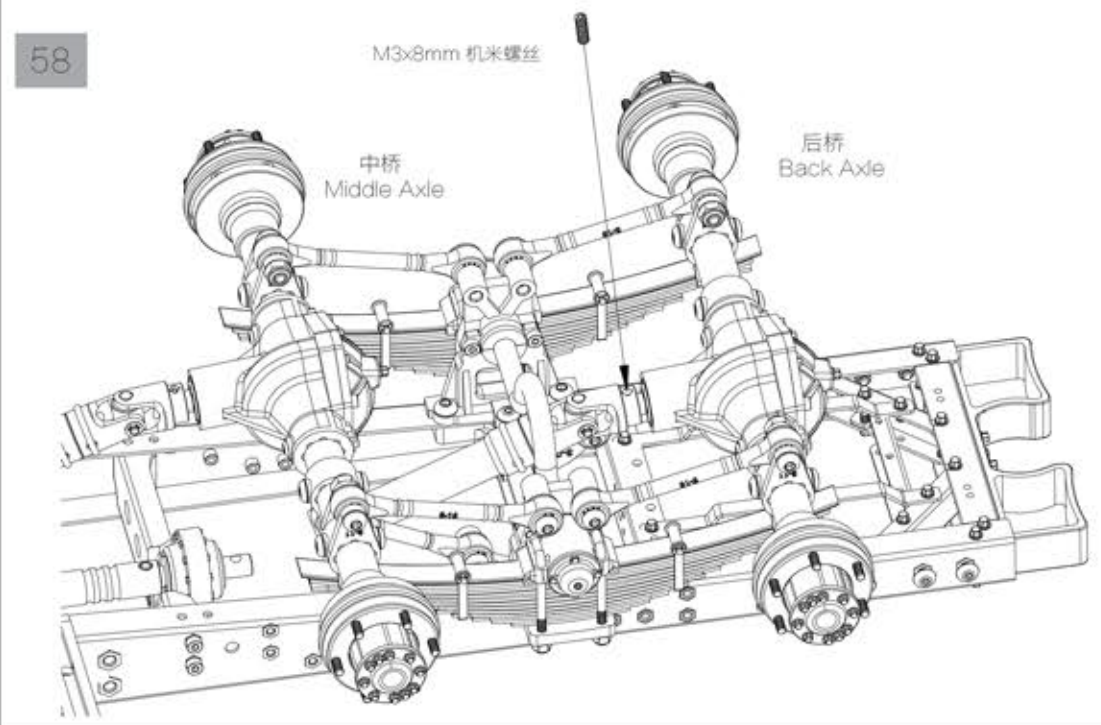

59

M3x8mm 机米螺丝 x1

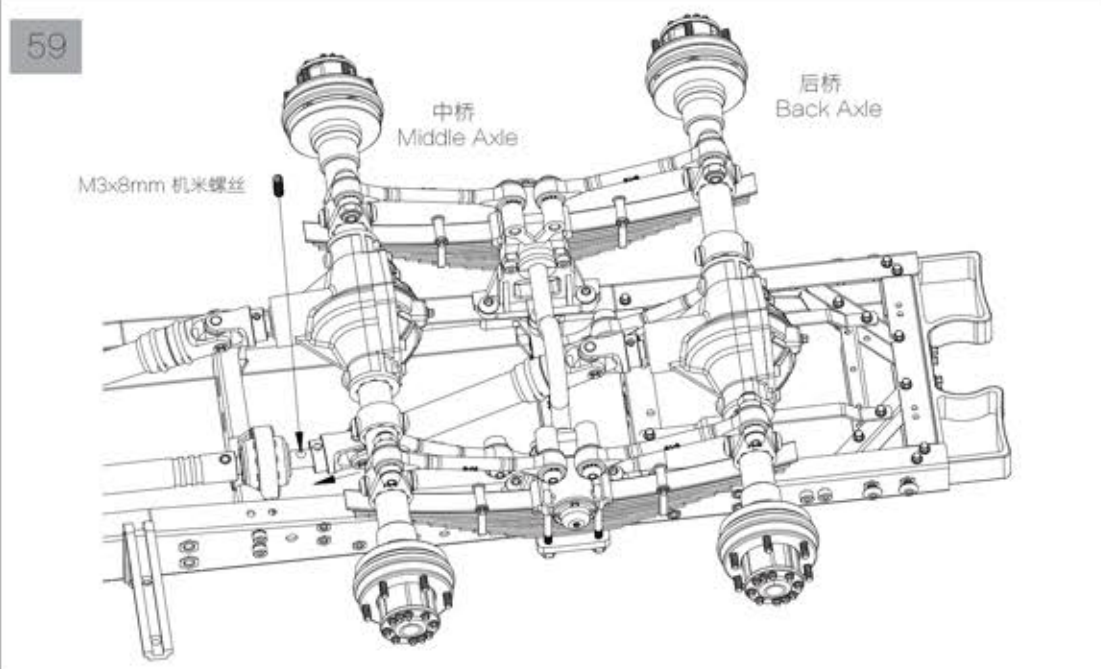

60

底盘安装完成示意图

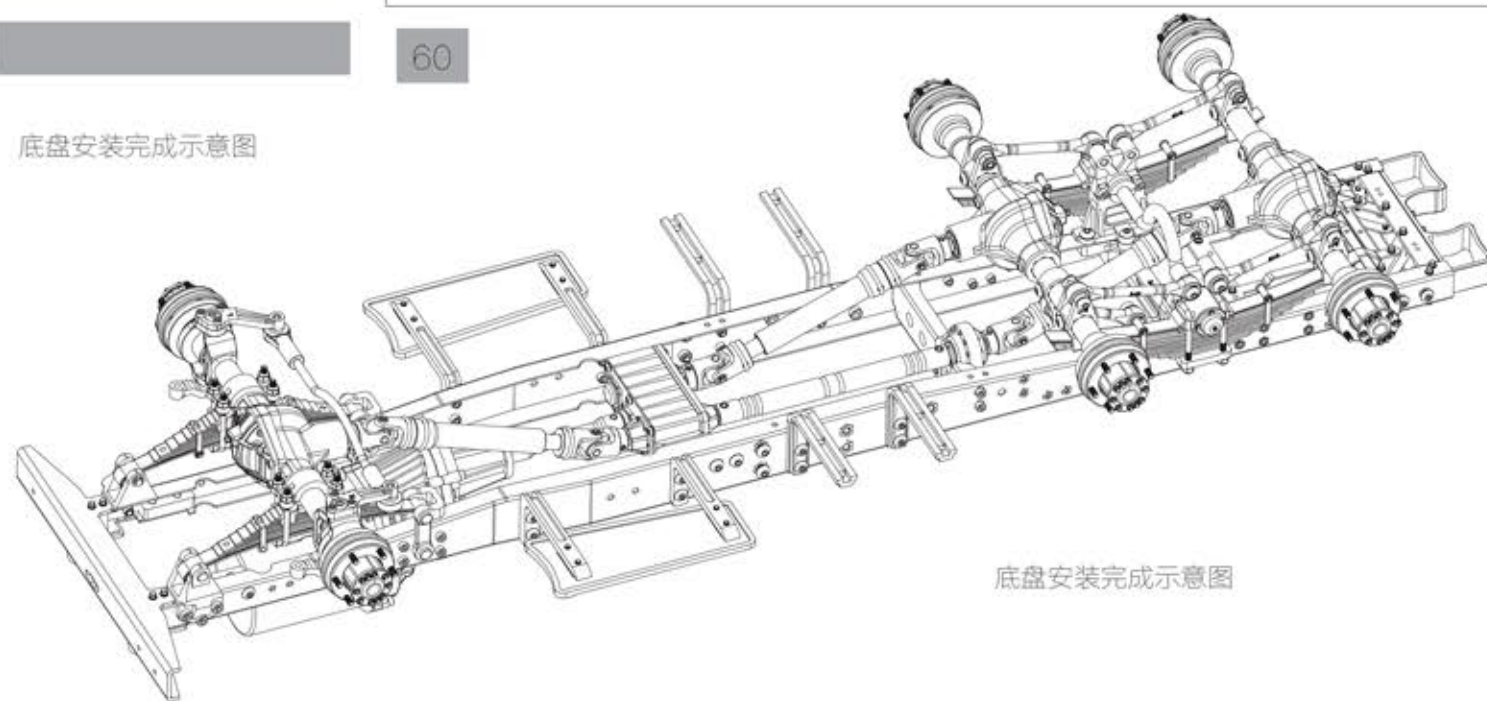

底盘安装完成示意图

27

M2x8mm 外六角 x 4

M2x6mm 外六角 x 4



H-A0031 x 2



H-A0033 x 4

28

前桥、前钢板分解示意图

29

M2 防松螺母 x 8



H-G001-001 x 4

27

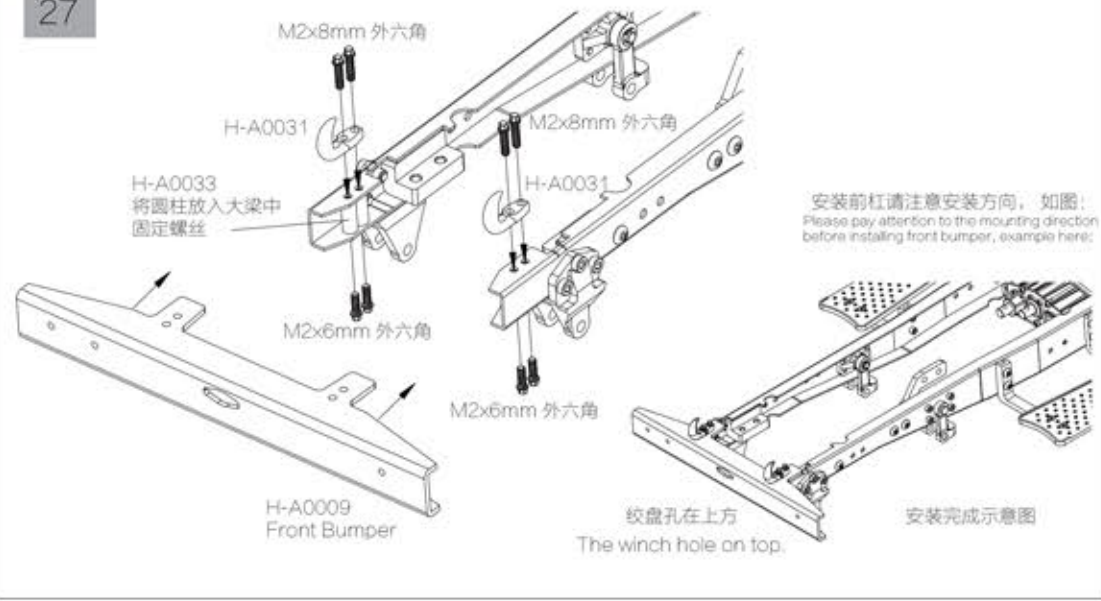

28

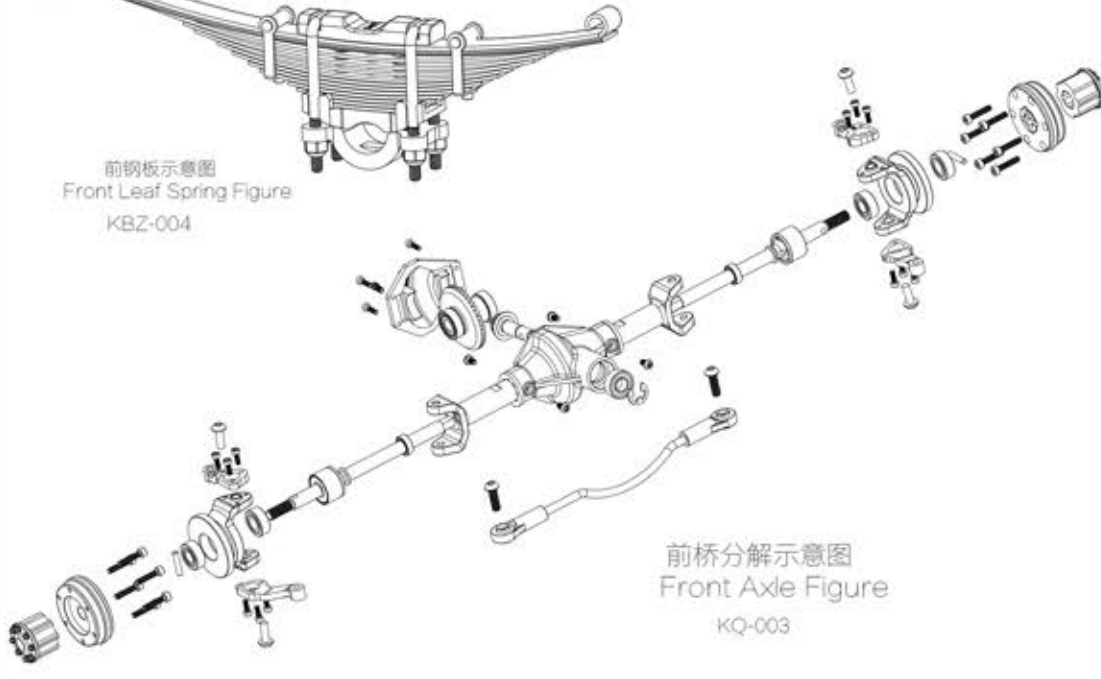

29

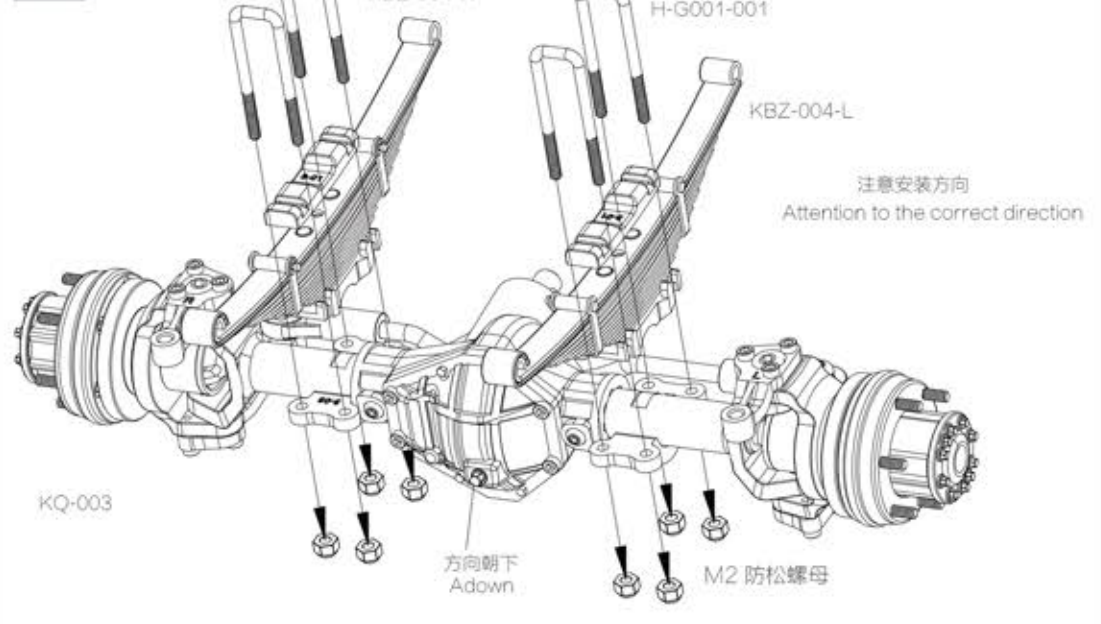

30

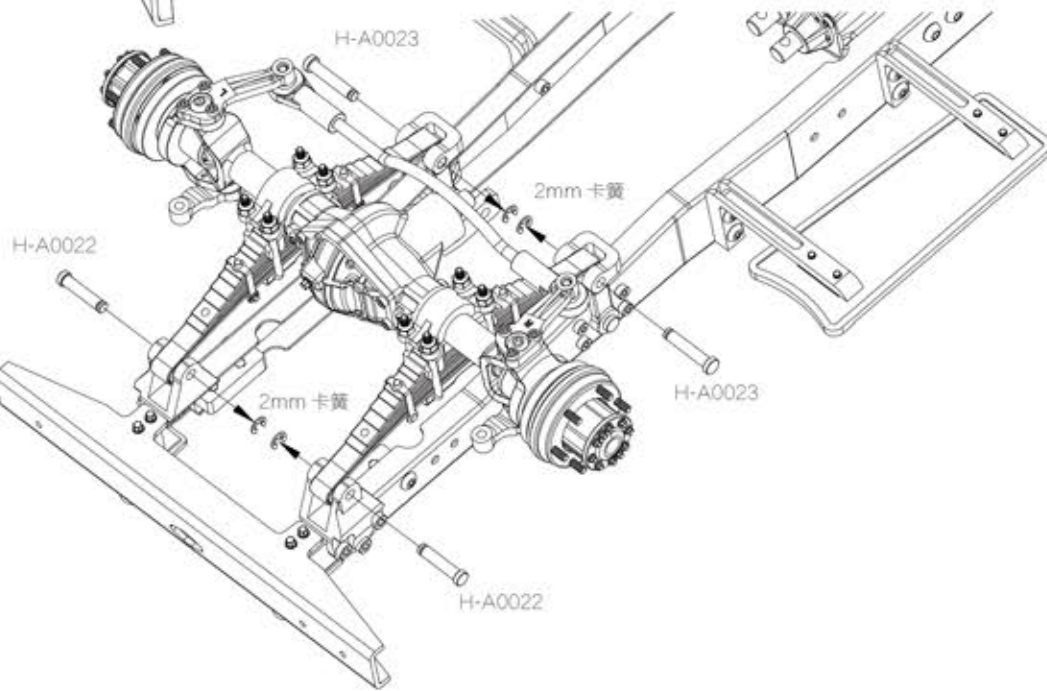
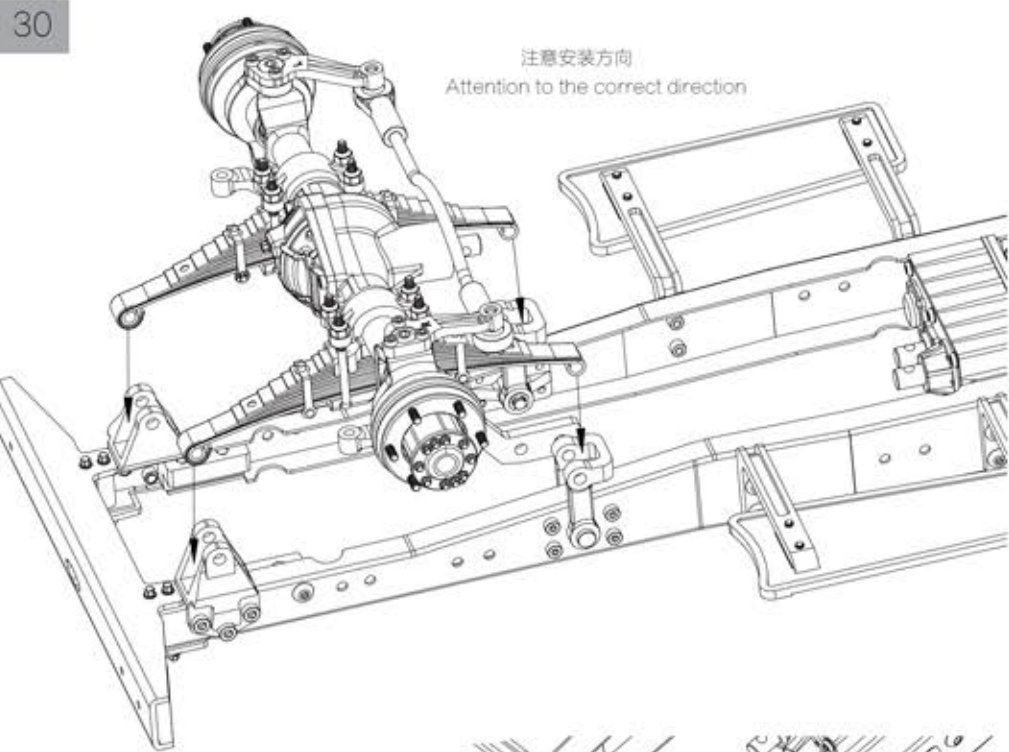

31

中桥分解示意图 Middle Axle Figure

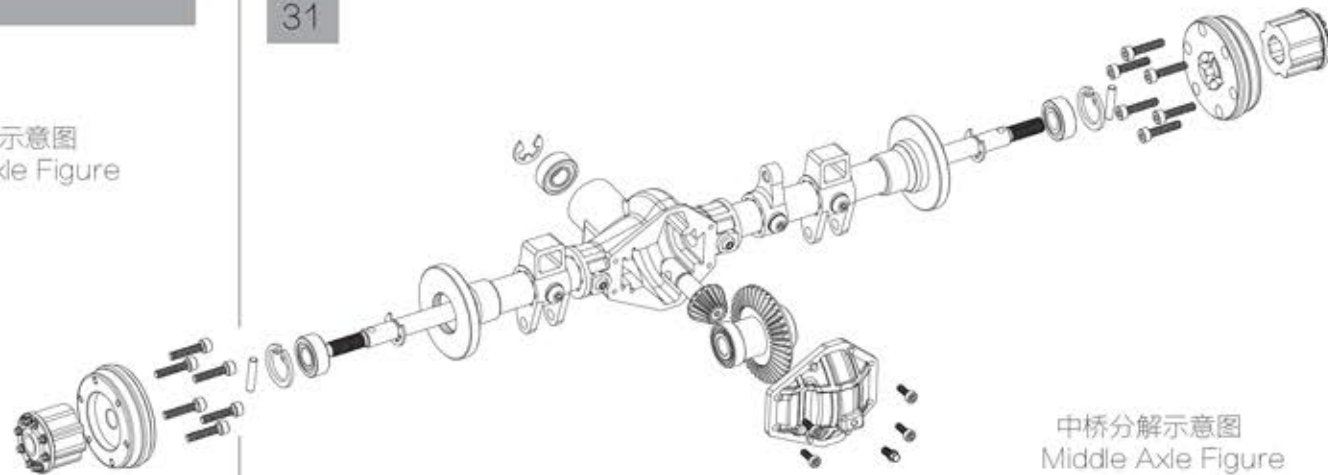

中桥分解示意图 Middle Axle Figure

KQ-004

55

55

M3x8mm 机米螺丝 x 1

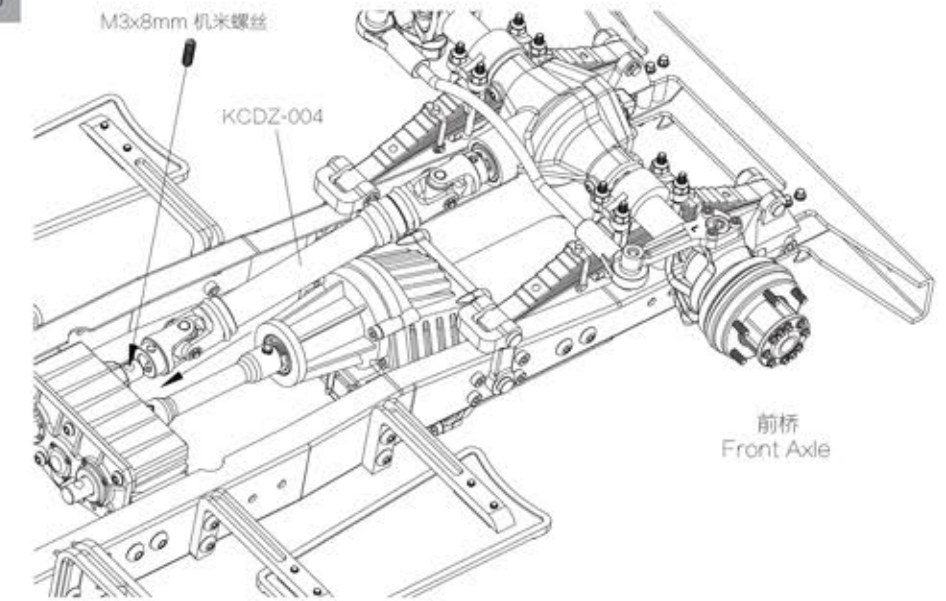

前桥 Front Axle

56

56

M3x8mm 机米螺丝 x 1

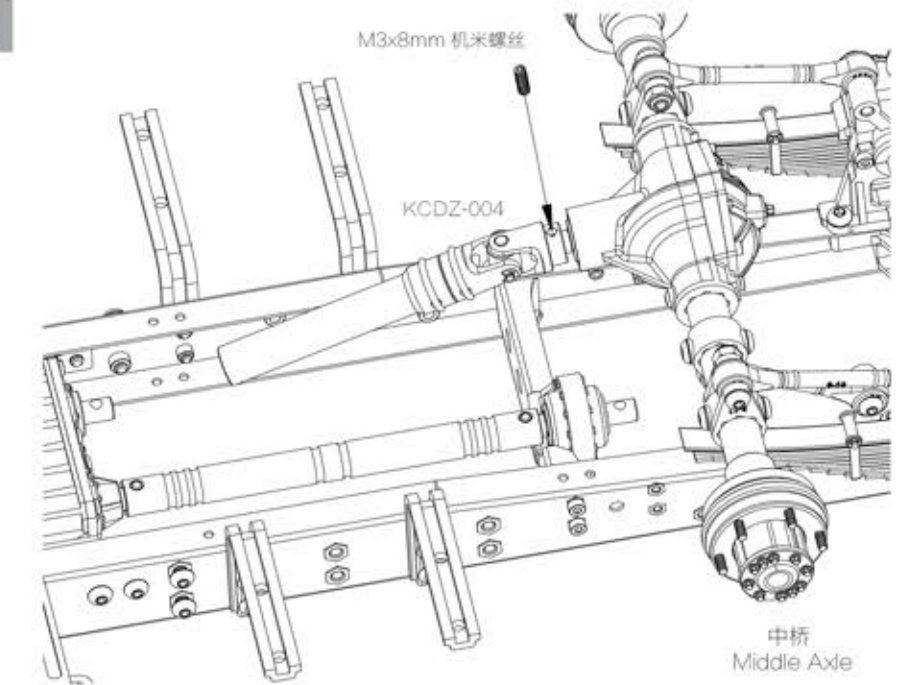

中桥 Middle Axle

57

57

M3x8mm 机米螺丝 x 1

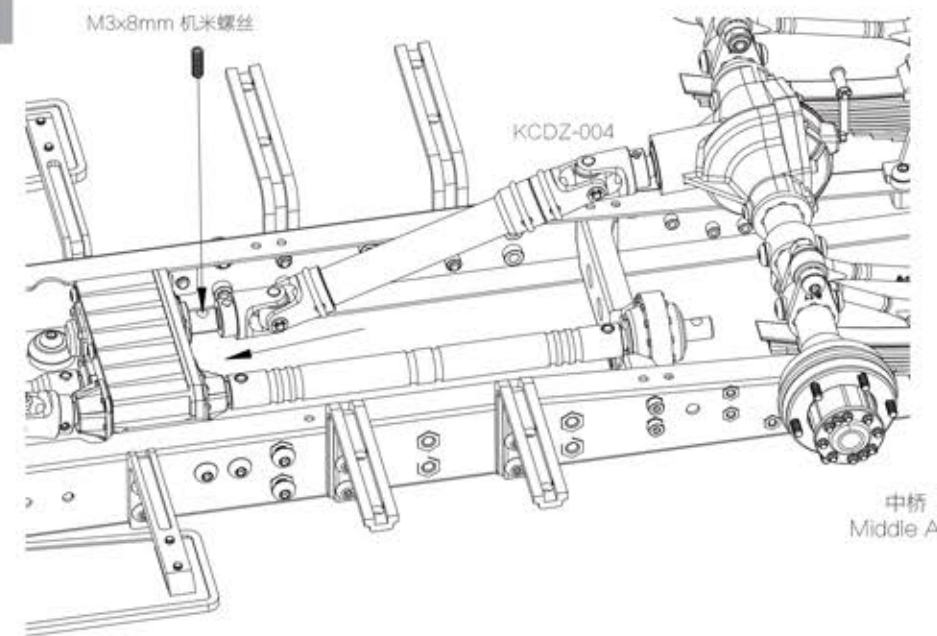

中桥 Middle Axle

52

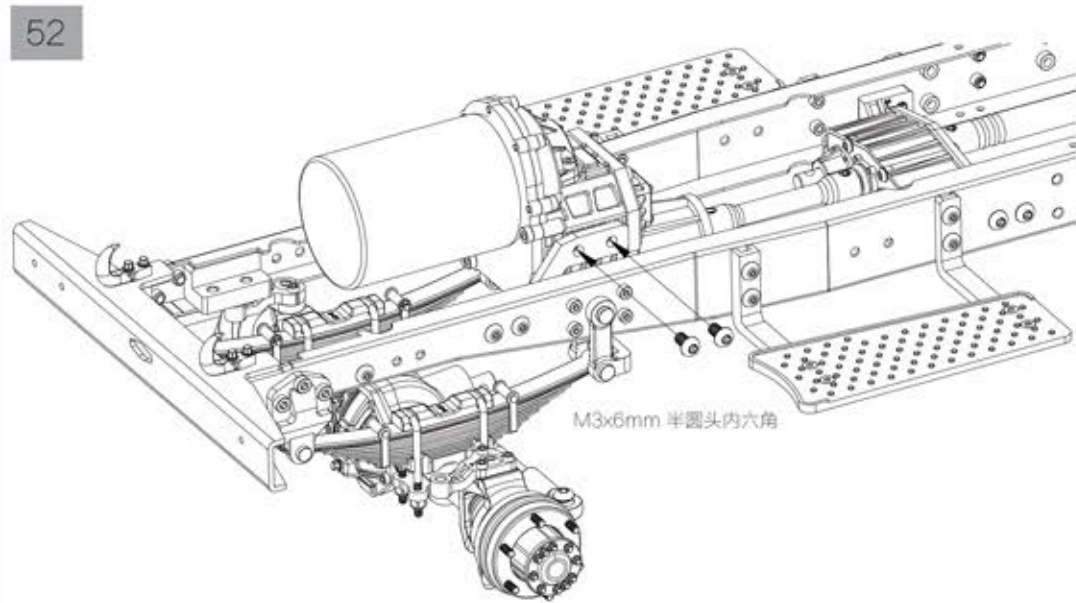

53

传动轴示意图

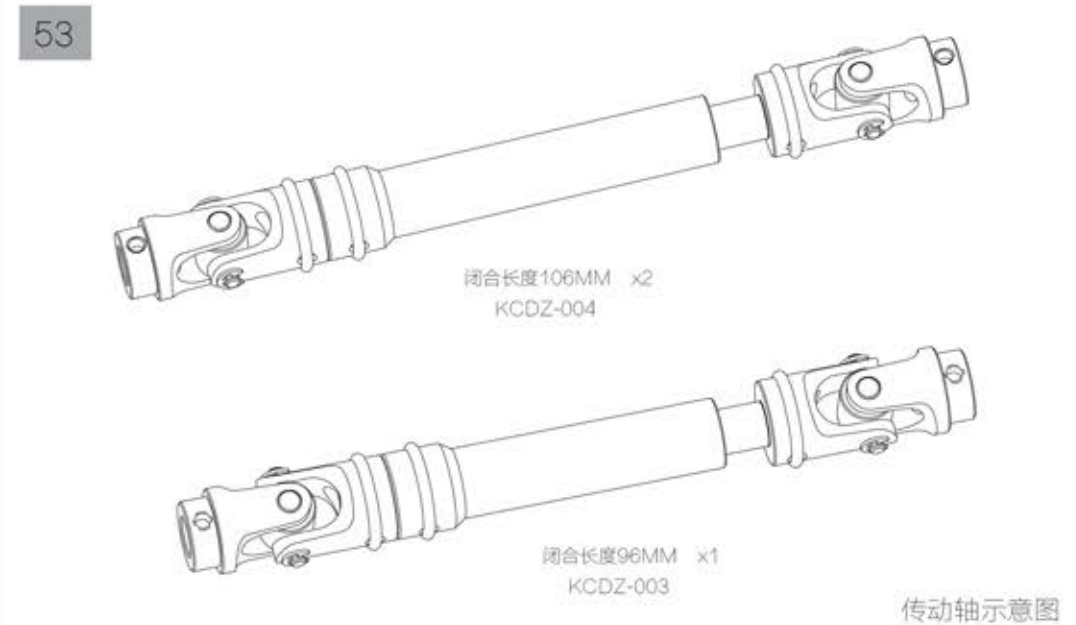

54

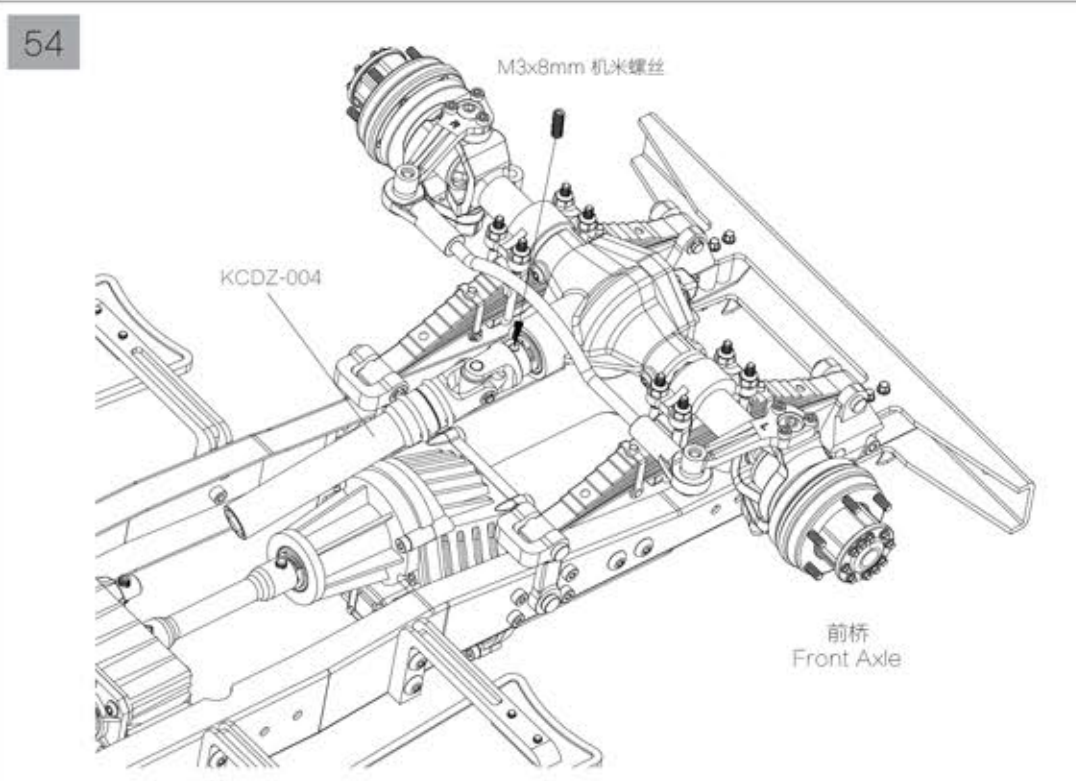

32

后桥分解示意图
Back Axle Figure

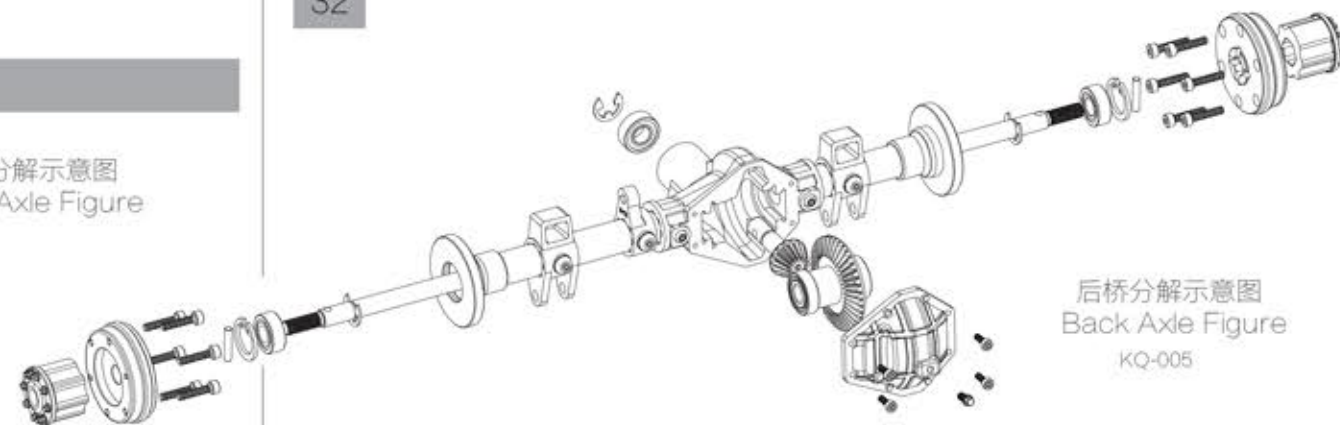

33

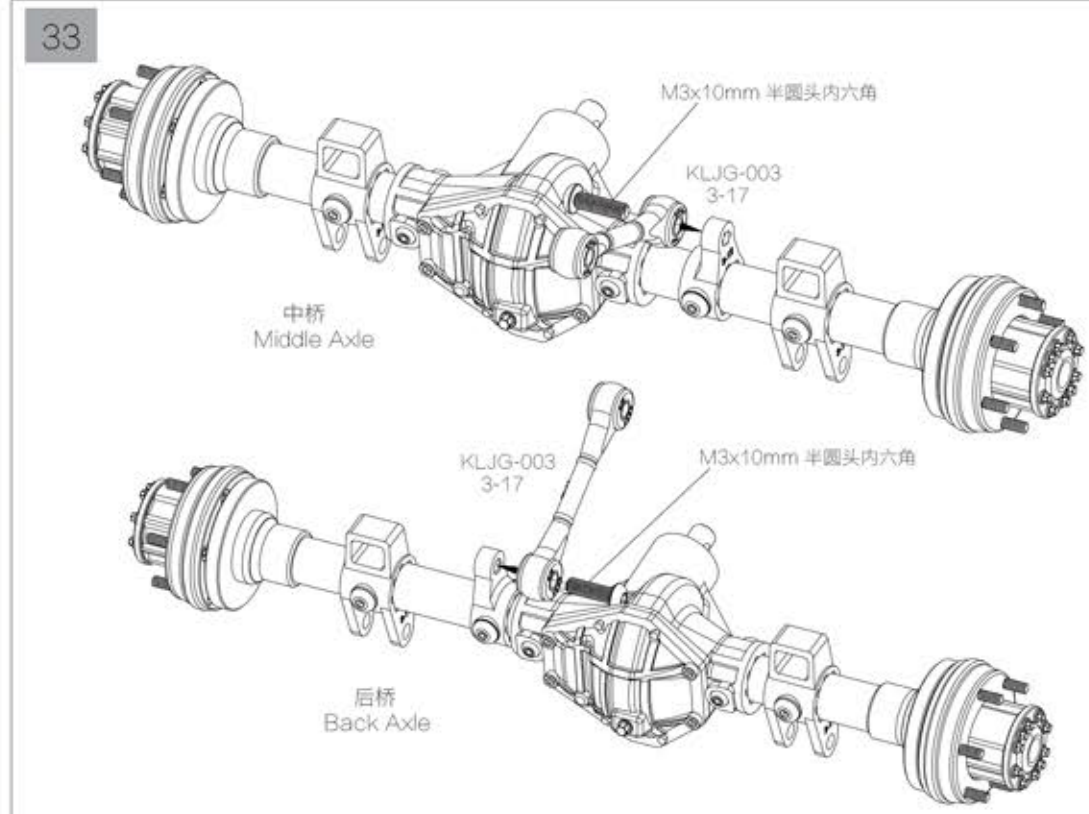

34

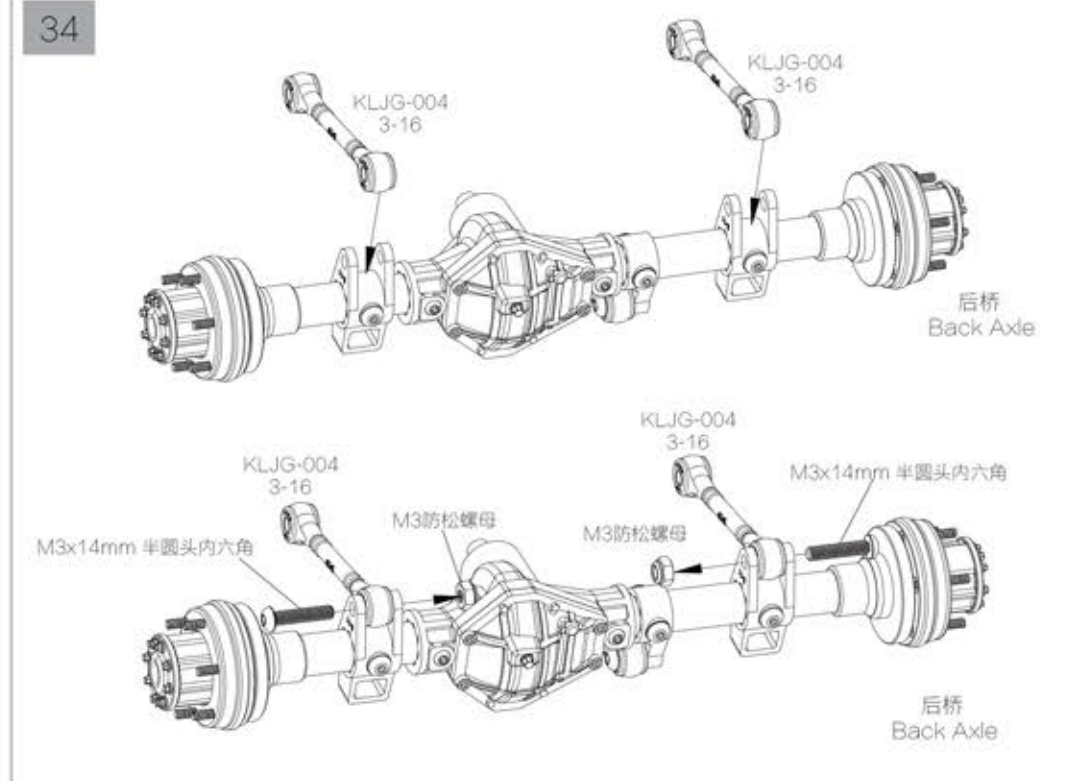

35

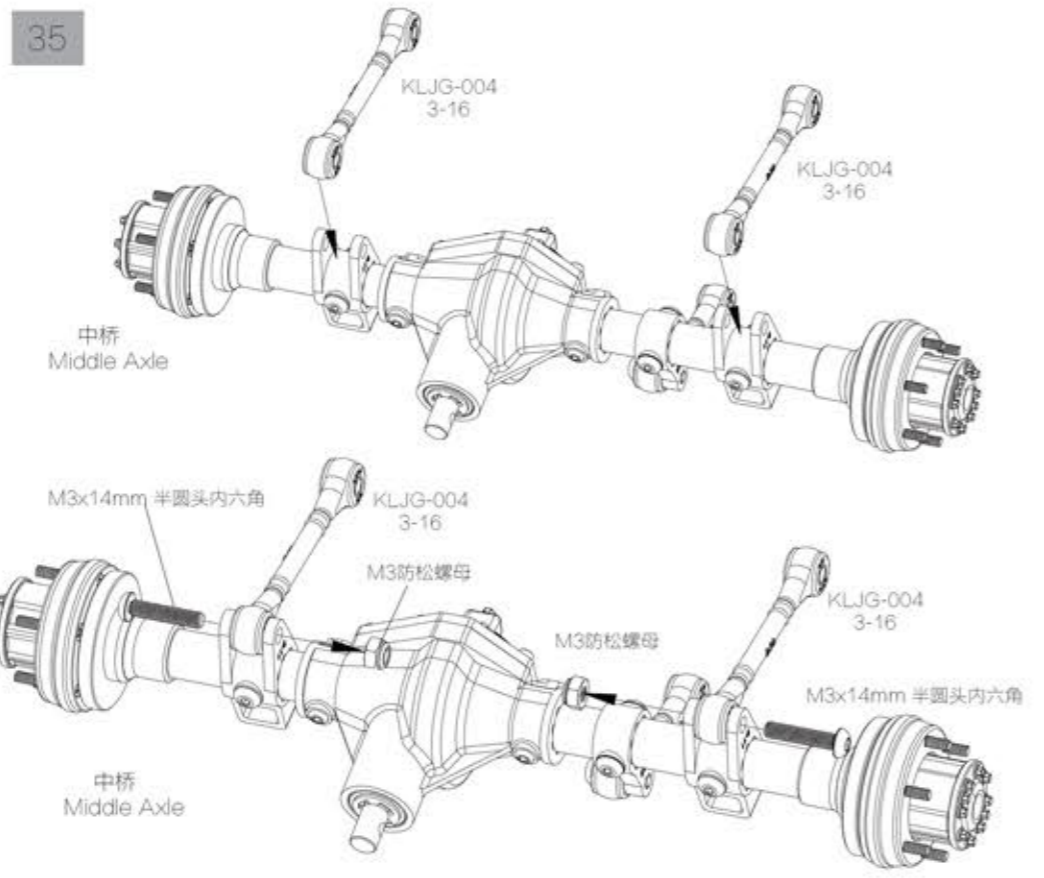

M3x14mm 半圆头内六角 x2
M3防松螺母 x2

36

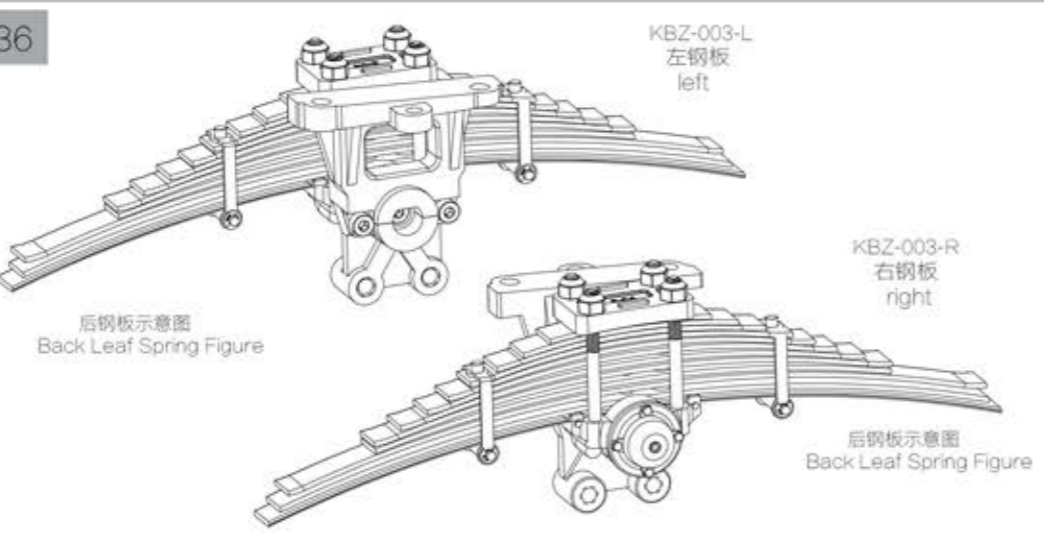

后钢板示意图
Back Leaf Spring Figure

37

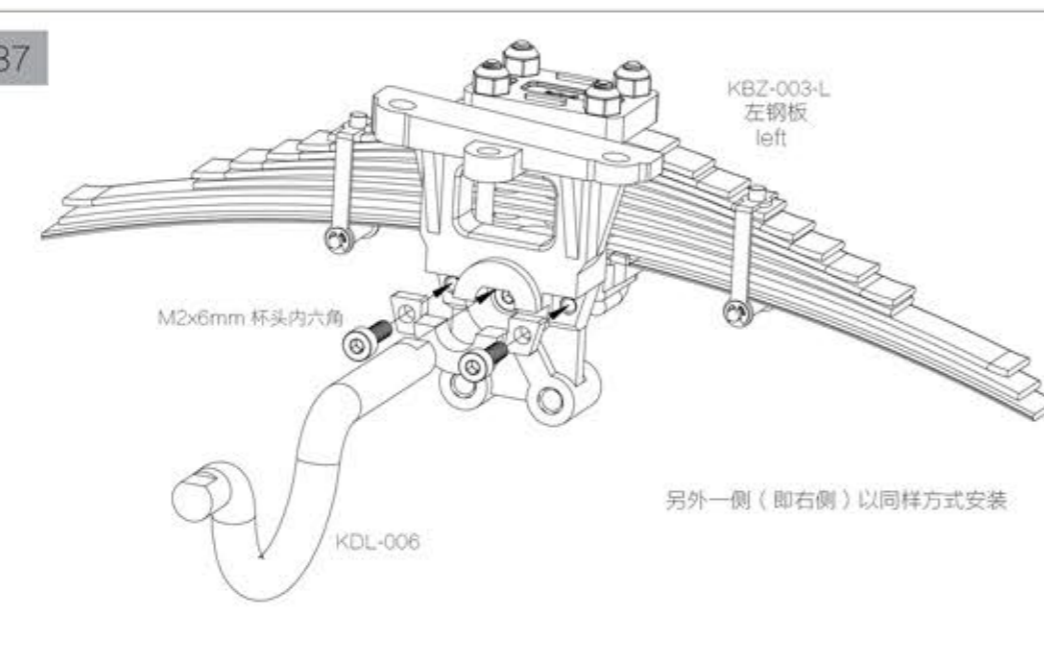

M2x6mm 杯头内六角 x4

49

安装波箱
Transmission installation

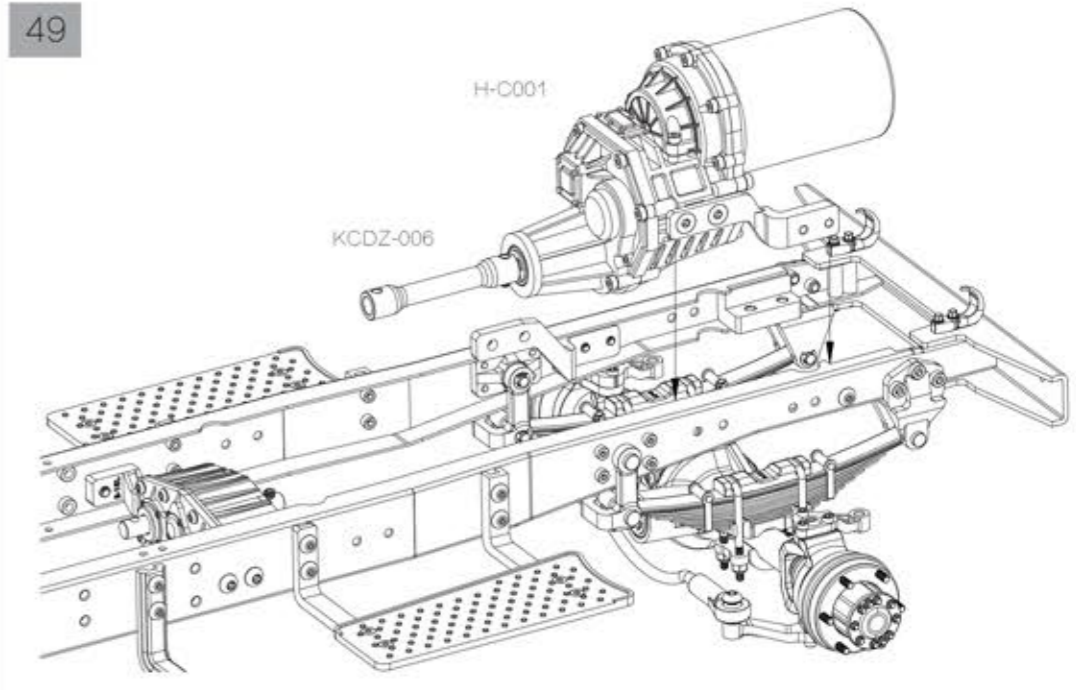

50

M3x8mm 机米螺丝 x1

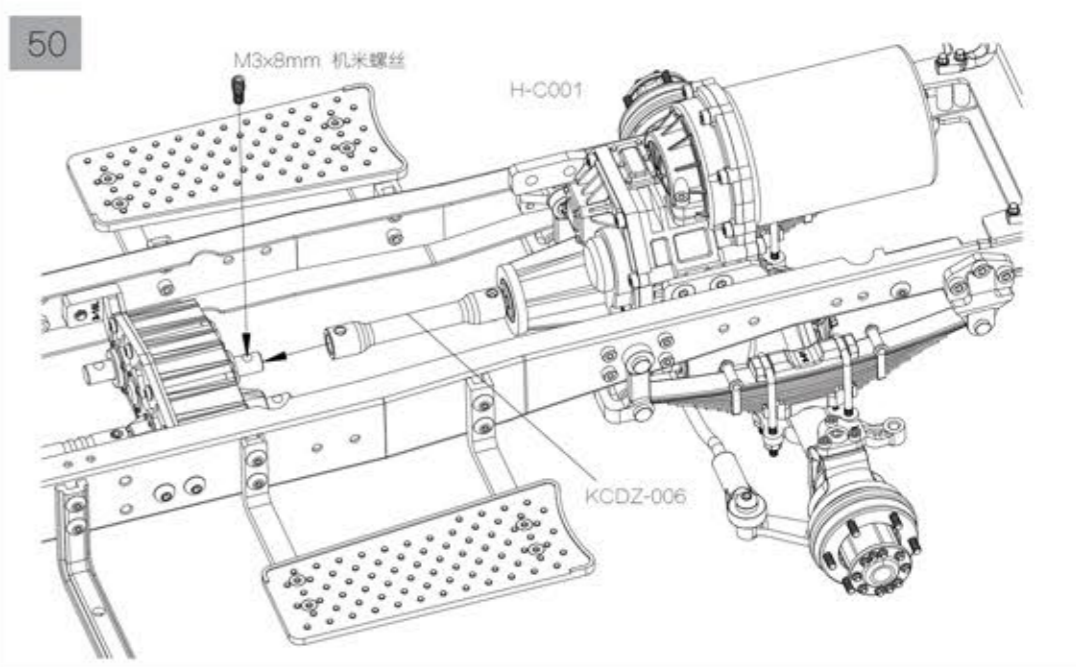

51

M2.5x6mm 半圆头内六角 x2

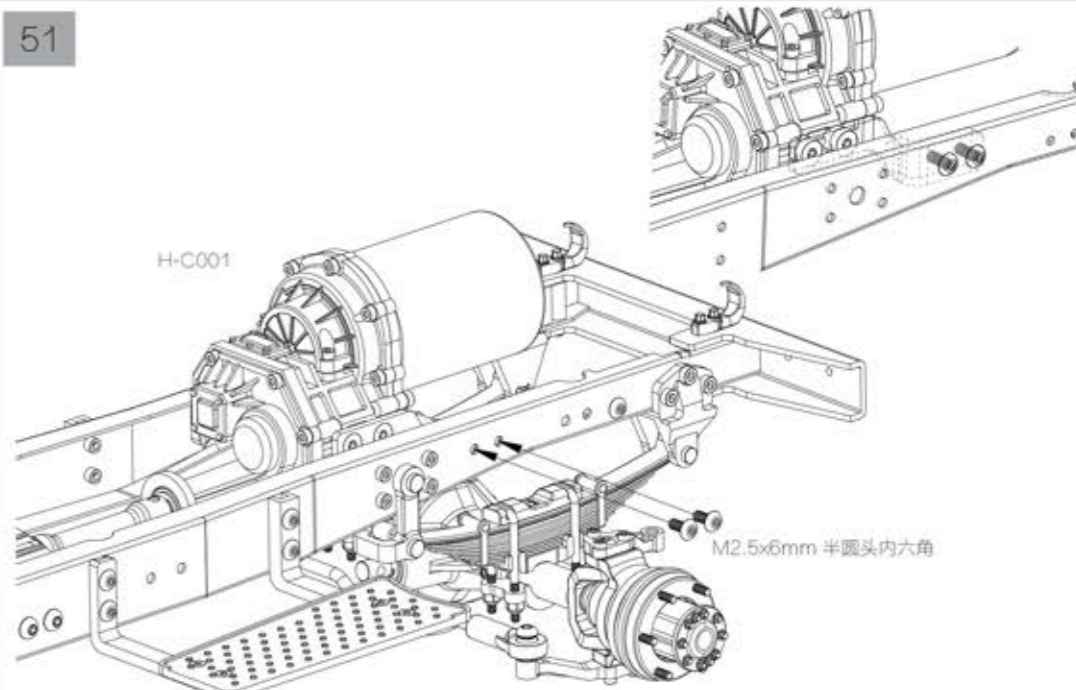

46

46

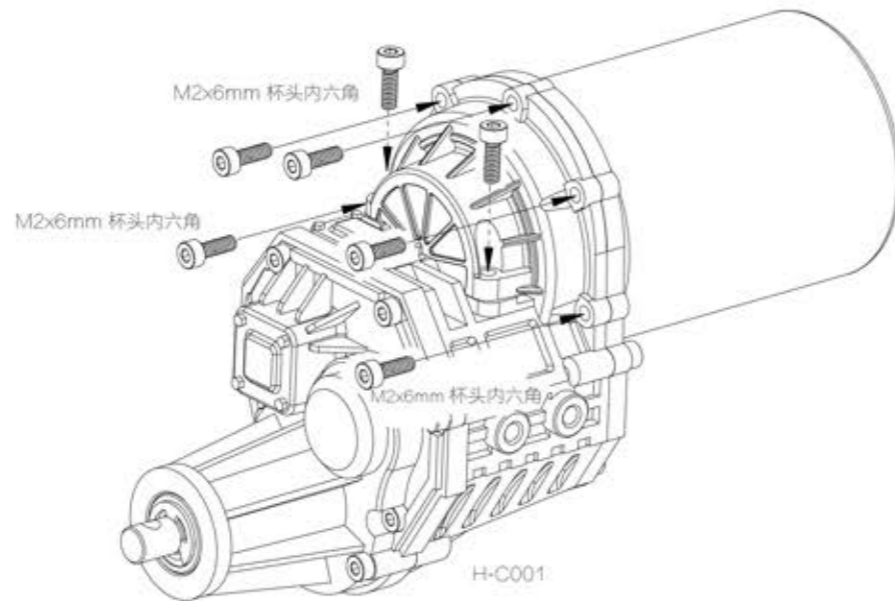

47

47

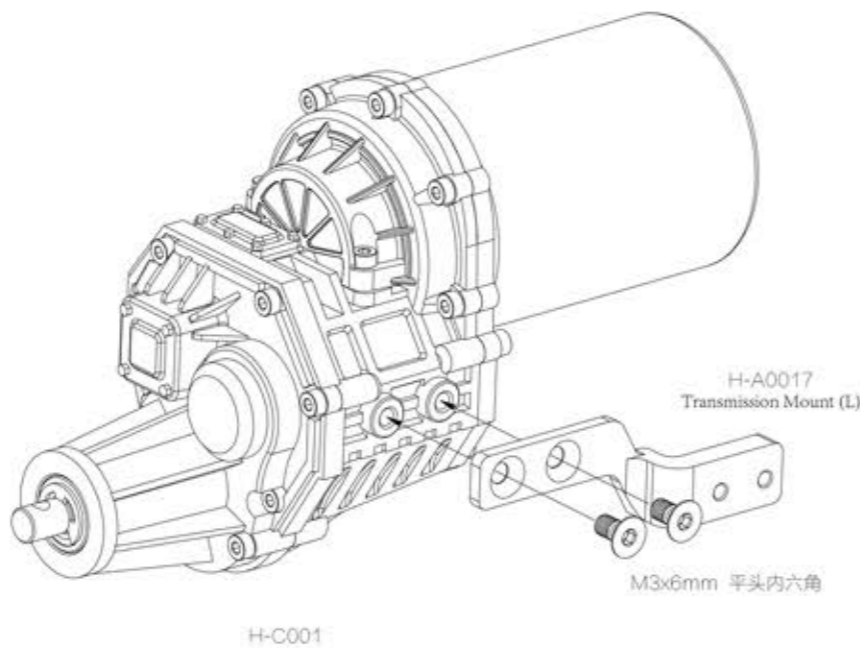

48

48

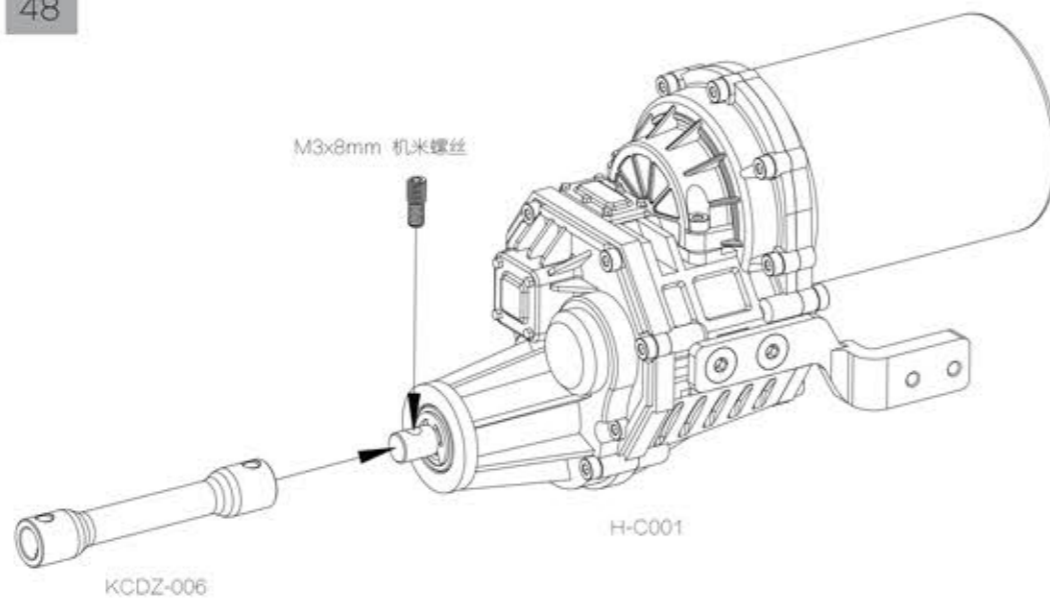

38

悬挂连接安装完成示意图

38

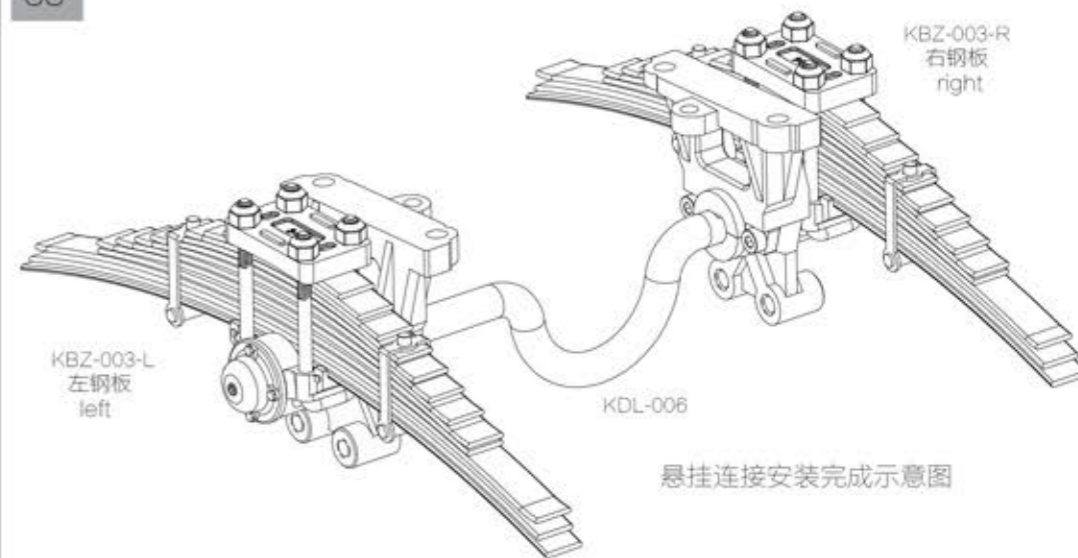

39

中桥、后桥与钢板安装示意图

39

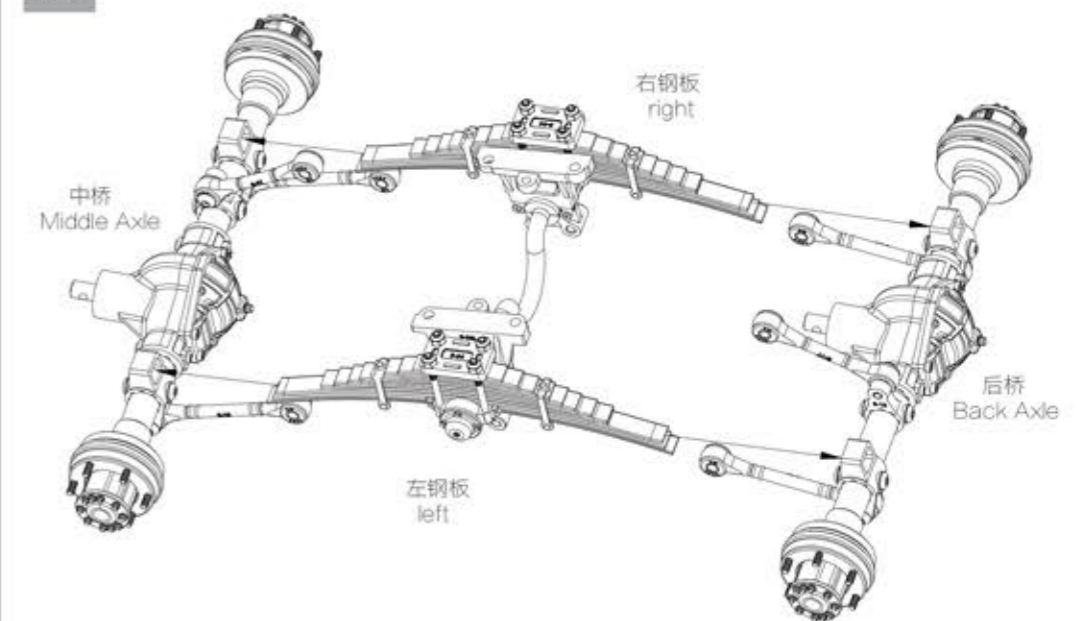

40



40

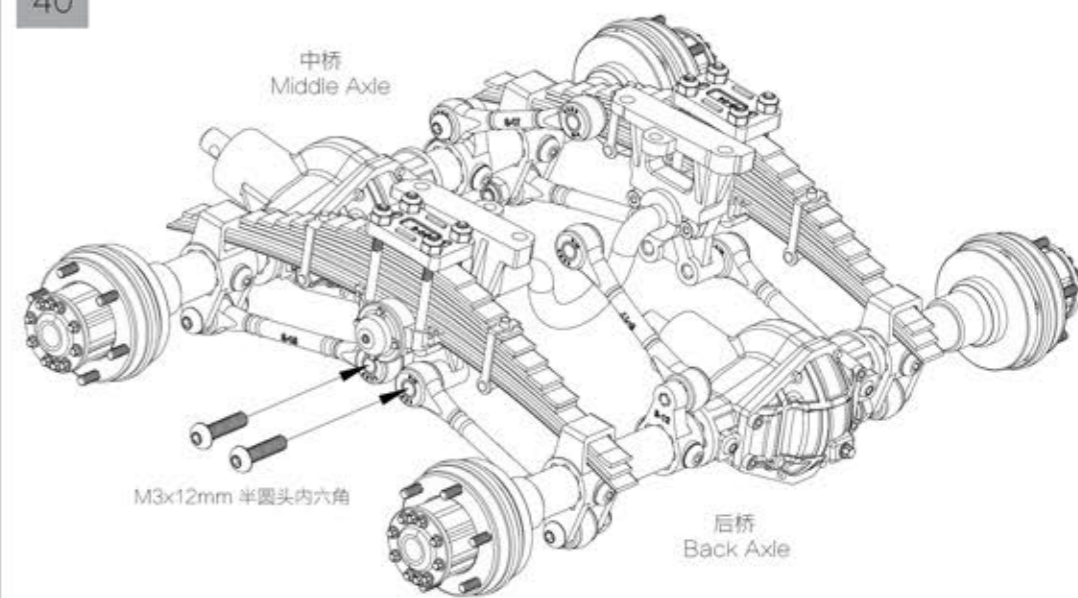

41

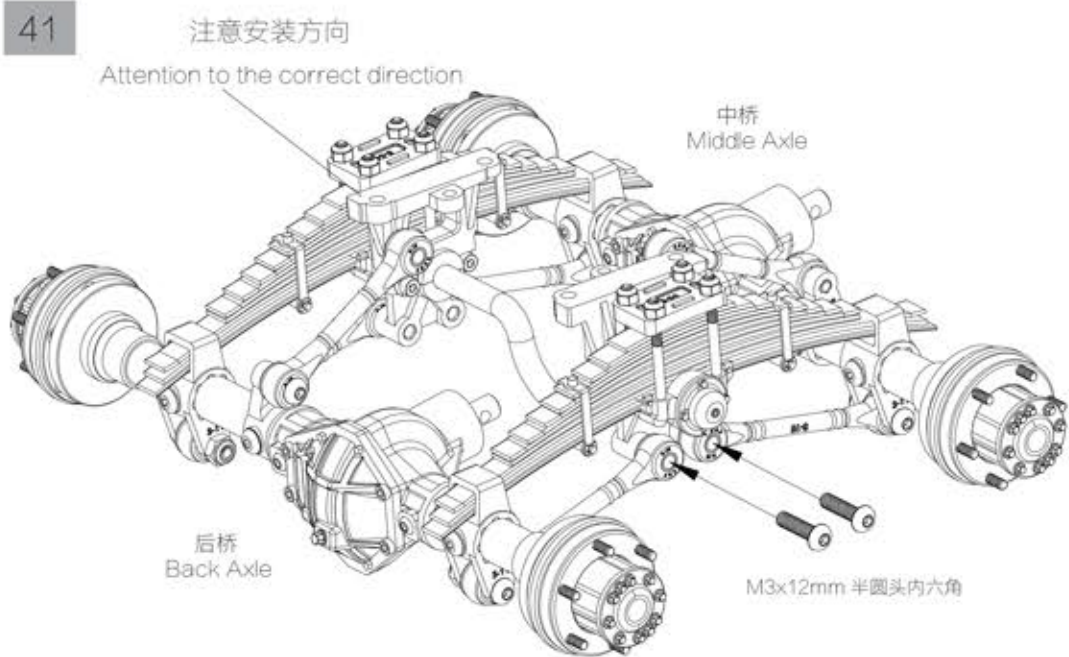

42

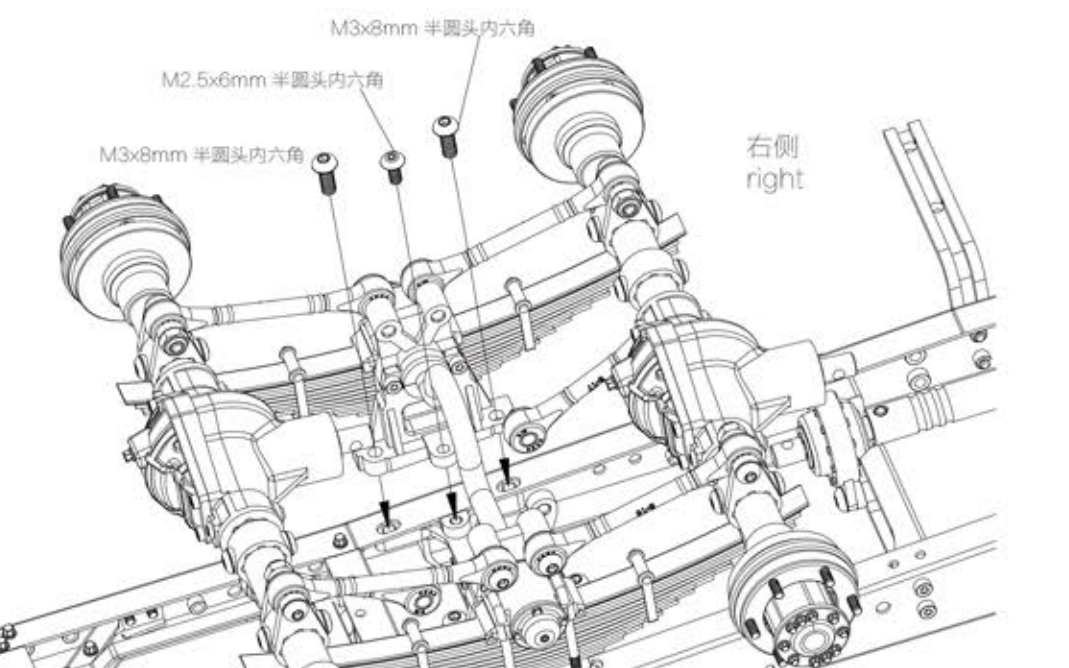
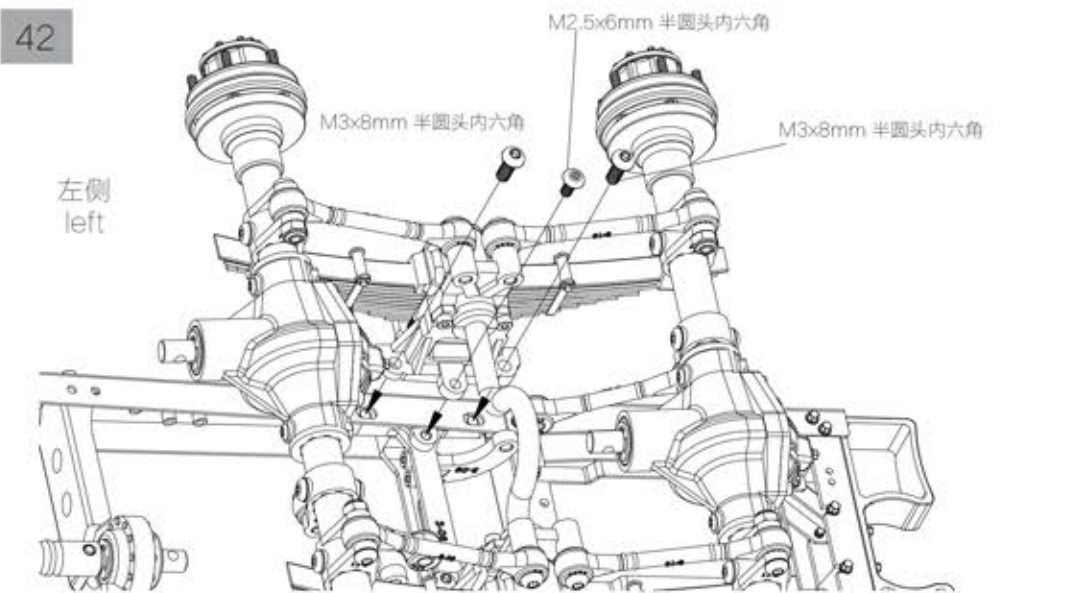

43



43

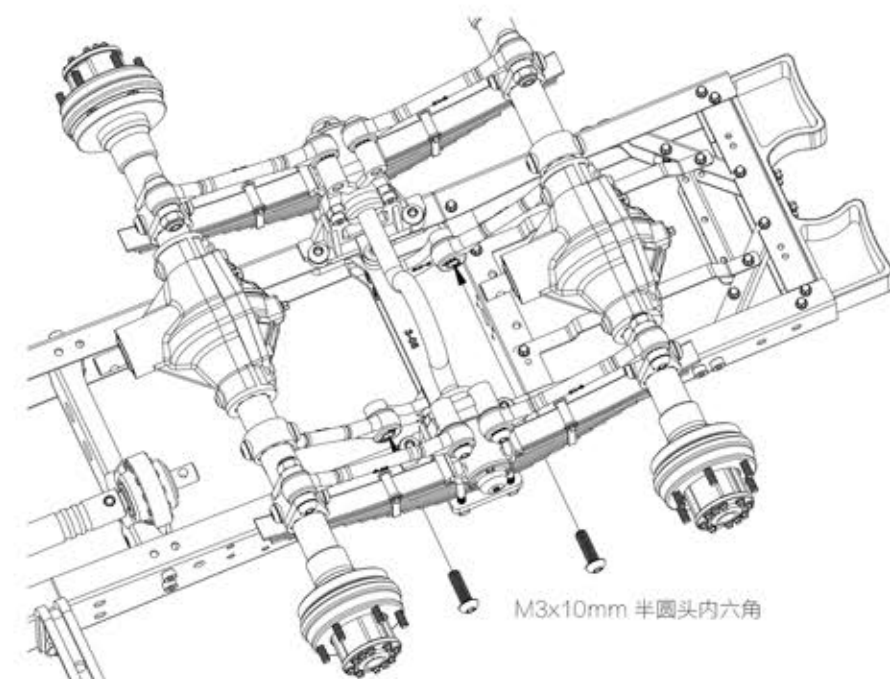

44



44

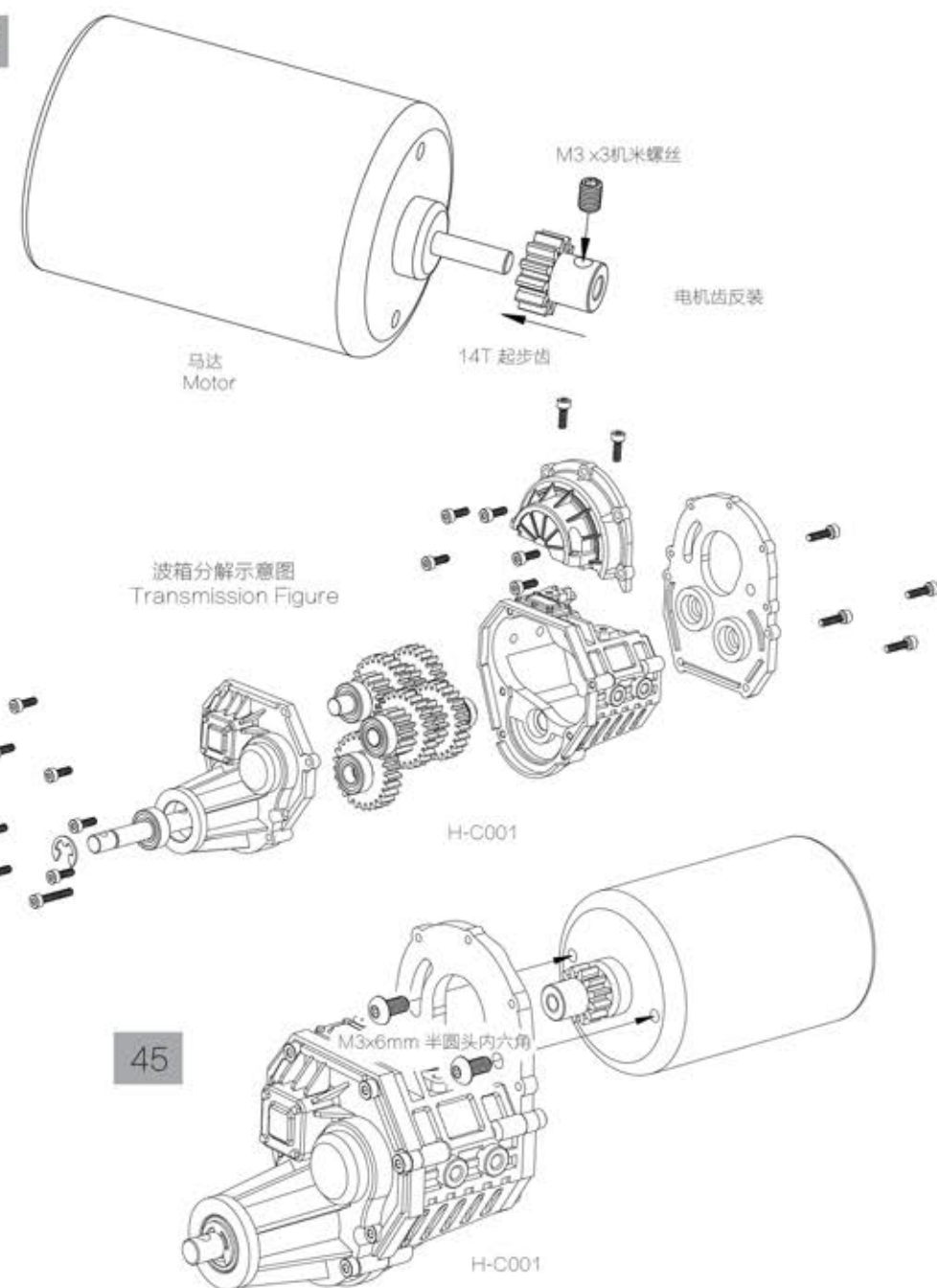

45

