

SCALE **4WD** Series

BOLT-ON KIT
PARTIAL ASSEMBLY REQUIRED

BOOMRACING®
Your Radio Control Car Specialist

BRX02

1/10 4WD RADIO CONTROL CHASSIS KIT FOR SERIES LAND ROVER

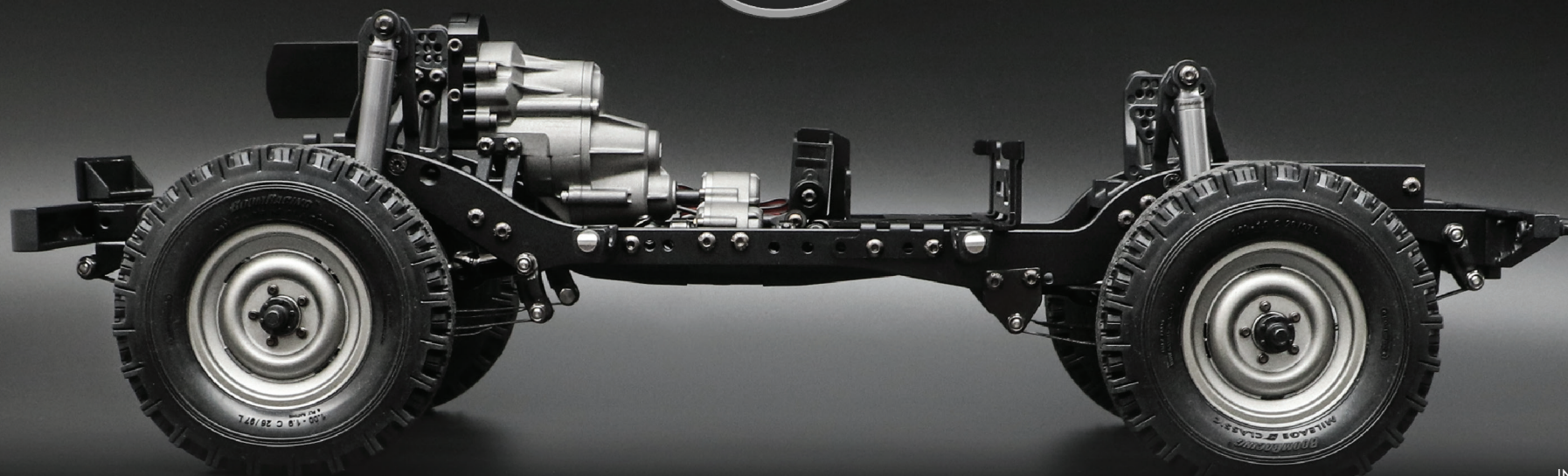

THE SCALE PERFORMANCE CONTINUES

Congratulations on your new BRX02 88 chassis!

Before you begin building, we want to express our gratitude for choosing Boom Racing products. As passionate R/C hobbyists ourselves, we strive to provide you with quality, fun-to-build, and high-performance products that we thoroughly enjoy too. We feel truly blessed to have the opportunity to design and manufacture hobby products for you. Without your support, we wouldn't be able to do what we do. So, thank you! If this is your first BRX vehicle, welcome to the Boom Racing family. Now, sit back, relax, and enjoy the build!

To start off, we'd like to introduce you to your unique license plates and VIN (vehicle identification number) system that identifies your vehicle as yours and only yours. All BRX02 88 chassis kits come with matching license plates, and all BRX chassis have unique VINs.

You can register your vehicle through our official website (<https://www.boomracing.com/vehicleregistration>). By registering your vehicle, you officially claim ownership, and no one else can claim it. As the registered owner, you become eligible to receive special promotions at any events hosted or attended by Boom Racing. Any future recalls, maintenance-related issues, and promotional offers, including priority pre-orders and giveaways, will be notified to you if you're registered. Once registered, vehicle logs will be kept for your future reference.

For a pre-owned vehicle, the new owner can view the history log of that vehicle. The vehicle ownership can be transferred from the registered owner to the new owner directly on our website to enjoy the same benefits, including our factory limited warranty.

Included with your BRX02 88 chassis kit is a set of classic UK license plates. The license plates consist of two groups of alphanumeric characters. The first three characters signify the BRX02 88 chassis. The numerical value following the first three characters, starting from 1, uniquely identifies each vehicle and matches the chassis number. Lastly, the last letter of the license plate identifies the chassis type - S for 88 and L for 109.



Scan to register your BRX02 88



A Bolt-On Kit means parts of the chassis are pre-assembled and require minor assembly for completion. The factory assembled parts offer convenience for builders eager to get started. The BRX02 kit includes factory pre-built axles and shocks. Shocks require oil to be filled (included).



The Scale 4WD Series is Boom Racing's line of scale based 4WD R/C products geared towards realistic appearance.



⚠ NOT RECOMMENDED FOR CHILDREN UNDER 14 ⚠

THIS CHASSIS KIT IS NOT A TOY. FIRST-TIME BUILDERS SHOULD SEEK ADVICE FROM PEOPLE HAVING BUILDING EXPERIENCE IN ORDER TO ASSEMBLE THE MODEL CORRECTLY. ASSEMBLE THIS KIT ONLY IN PLACES OUT OF CHILDREN'S REACH.

⚠ CAUTIONS ⚠

BEFORE YOU PROCEED

Congratulations! Owning the BRX02 88 is a truly special experience.

Carefully read and follow all instructions to prevent serious damage to your model. Failure to follow these instructions will be considered abuse and/or neglect.

Study the instructions thoroughly before assembly.

There are many small screws, nuts and similar parts. Assemble them carefully referring to the drawings. Follow the steps exactly as shown to build the vehicle correctly without issues.

If you decide to return the BRX02 88, do not begin assembly. Your hobby dealer will not accept a model for return or exchange after you have started assembly.

Boom Racing offers Spare Parts & Upgrade Options for improved performance. Visit our website (<https://www.boomracing.com>) or your local Boom Racing dealer for assistance. Please note that specifications, availability and price are subject to change without notice.

SAFETY PRECAUTIONS

All of us here at Boom Racing want you to enjoy your new vehicle. Operate your BRX02 88 sensibly and with care, and it will be exciting, safe and fun for you and those around you. Failure to operate your BRX02 88 in a safe and responsible manner may cause damage and injury and void your warranty.

Follow these outlined rules for safe radio control operation

- Read carefully and fully understand the instructions before assembly.
- ***This model is not intended for use by children (minors) under 14 years of age without the supervision of a responsible and knowledgeable adult who should also read the instructions.***
- When assembling this kit, extra care should be taken to avoid personal injury. Keep out of reach of small children.
- Avoid running the vehicle in crowded areas and near small children.
- BRX02 88 can be very fast and quiet. It could cause injury to those unaware of its presence.

Inspect Your BRX02 88 Before and After Operation

- Make sure that all screws and nuts are properly tightened.
- Use thread lock on screws for any metal on metal surface.
- Adjust steering servo and trim so that the BRX02-88 runs straight with transmitter in neutral.
- Disconnect/remove all batteries after operation.
- Replace any batteries that have been dented, are bloated, or have frayed wires, short circuits can cause fire.
- Completely remove sand, mud, dirt etc after use to prolong the life of the BRX02-88.
- Maintain bearings by cleaning or replacing them regularly.

WARRANTY

Boom Racing's One (1) Year Factory Limited Warranty – A Peace Of Mind Right From The Start

WHO IS COVERED

This warranty is extended to the original end-user that registers it online (<https://www.boomracing.com/vehicleregistration>) only, whether purchased or received as a gift.

FACTORY LIMITED WARRANTY

What Is Covered and For How Long

Boom Racing warrants that all new products are free from defects in manufacturing, materials and workmanship for a period of one (1) year from date of retail purchase. The receipt or invoice at the time of purchase is your proof of purchase and is required for Boom Racing to honor any warranty.

What Is Not Covered

It does not cover defects or malfunction caused by user error of assembly, damages due to normal wear and tear, failure to follow operating instructions, misuse or abuse, users' failure to perform routine maintenance, or use with products with which is not intended to be used. It also does not cover damages caused by unauthorized alteration, modification or repair. It does not cover cosmetic or incidental damages. Boom Racing does not warrant or provide service or support for any third party products.

The JX mini servo warranty will be void if it is disassembled.

What We Will Do

We will, at our discretion, repair or replace any product free of charge that is incorrectly made or proves to be defective in material or workmanship during the warranty period. If your product is no longer being manufactured or is out of stock, we may replace your product with a comparable or improved product at our option.

What We Will Not Do

We will not pay for shipping, insurance or transportation charges from you to us, or any import fees, duties and taxes.

What To Do To Obtain Warranty Service

To obtain warranty service for products purchased from a third-party, retail or directly from Boom Racing you must return the product with proof of purchase using the following procedures:

1. Contact Boom Racing Customer Support for specific warranty instructions via our website, by email, telephone, or our social media accounts:
 - Online @: <https://www.boomracing.com/contact-us>
 - Email: sales@boomracing.com
 - Telephone: 1-209-676-8880

You may be asked to complete a warranty service request form. A copy of your purchase receipt may be required.

2. Our Customer Support may ask you to return and ship the defective product back to us. Label and ship the product, freight prepaid, to the address provided by Boom Racing; and
3. Place any necessary return authorization number prominently on the outside of the return packaging. Return packaging not bearing a return authorization number where required may be refused.

Boom Racing reserves the right to final decision, change or modify this warranty without notice.

Equipment Required



3CH Radio

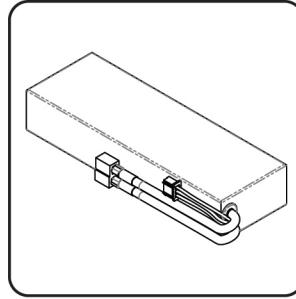

Battery

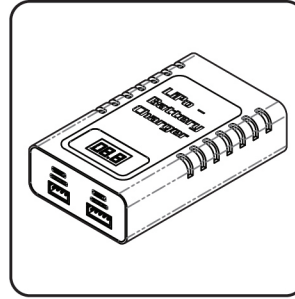

Charger

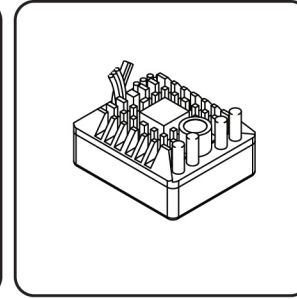

ESC

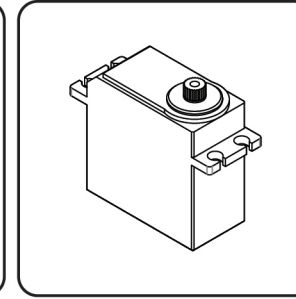

Steering Servo

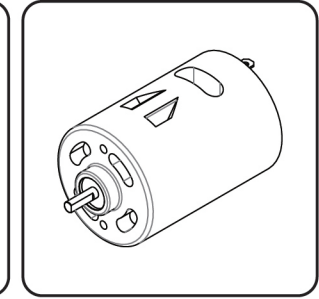

540/550 Motor

Tools Recommended

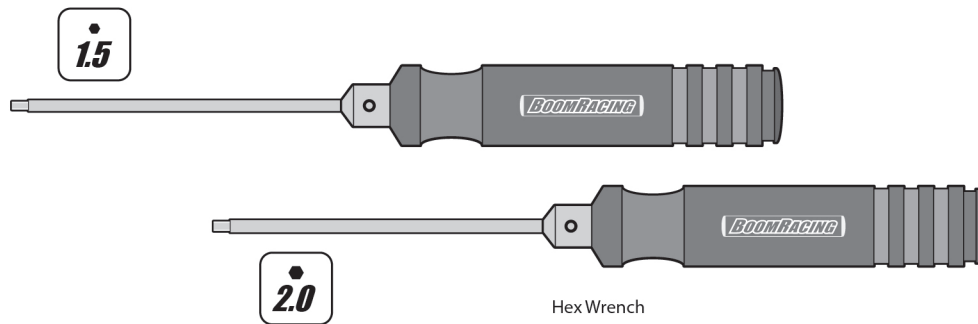

Hex Wrench

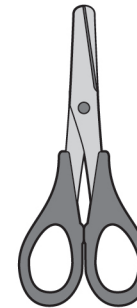

Scissors



Hobby Knife



Slot Screwdriver

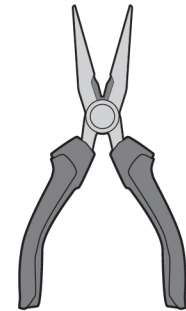

Long Nose Pliers



Thread Lock

Apply thread lock to places shown by this mark.
Apply thread lock first, then assemble.
(Do Not Use Red Loctite)



Black Graphite Grease

Lubricate all gears.
Apply grease to the places shown by this mark.
Apply grease first, then assemble.



Silicone Grease

Lubricate all moving parts including joints and bearings.
Apply grease to the places shown by this mark.
Apply grease first, then assemble.



Shock Oil

Apply shock oil to the places shown by this mark.



Apply Double Side Tape



Item not included.



Pay attention to note on page.

1

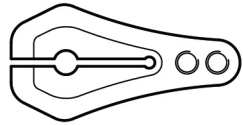

Servo Horn A - 25T x 1
#BR955014BK

3

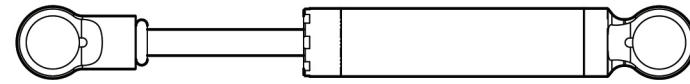

KUDU™ 80mm Scale Shock Absorber x 4
#BRSH0080

2



Shock End Pivot x 8
#BRW750310



Joint Retainer x 10
#BRSHJR

4

#BRX0290011

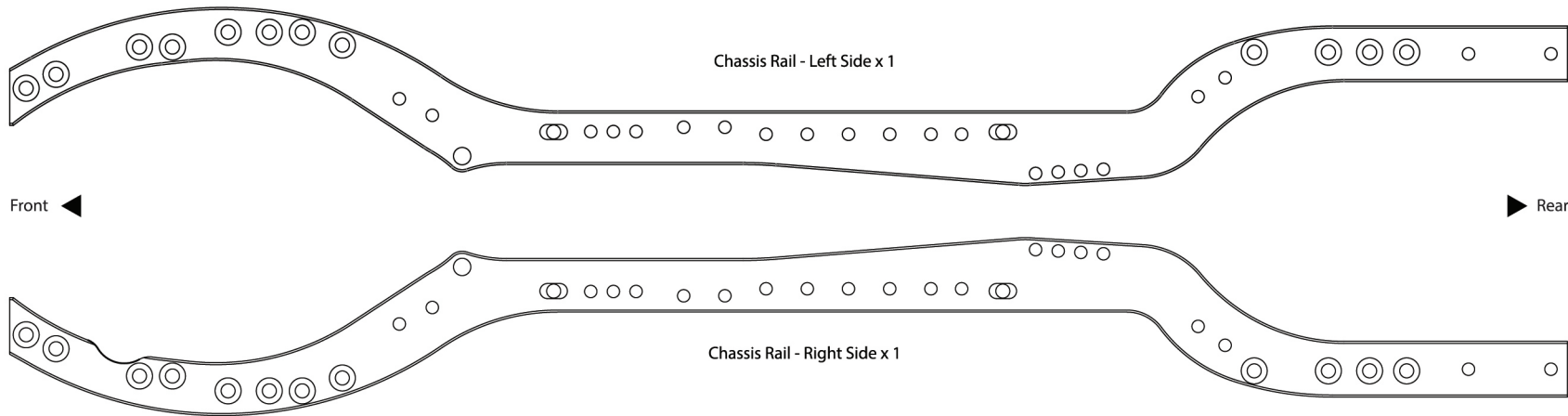

Chassis Rail - Left Side x 1

Chassis Rail - Right Side x 1

Front ◀

▶ Rear

5



Front Anti-Wrap Bar x 2
#BRX020027

6



Brass Washer x 4
#BRX020030

7

#BRLC7064A

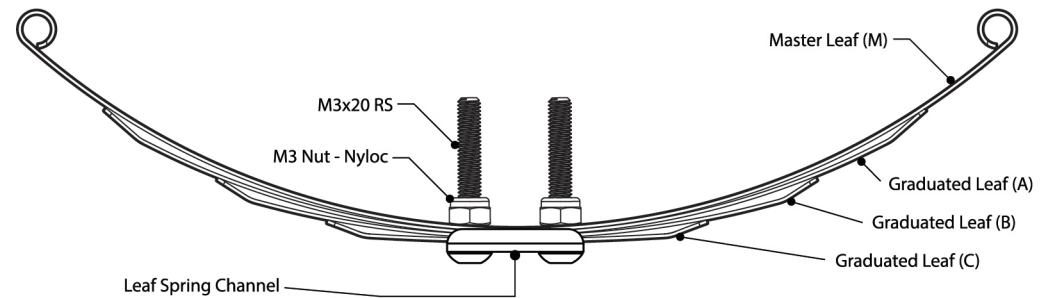

Master Leaf (M)

M3x20 RS

M3 Nut - Nyloc

Graduated Leaf (A)

Graduated Leaf (B)

Graduated Leaf (C)

Leaf Spring Channel

8

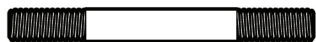

Stainless Steel M4x40 Anti-Wrap Bar x 2
#BRLC7064C

4 sets

9

#BRX020064B



Front Leaf Retainer
- Left x 1

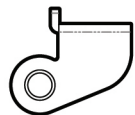

Front Leaf Retainer
- Right x 1

10

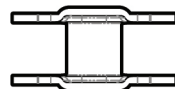

Leaf Spring Shackle Type-B x 4
#BRX020064A

11

#BRLC7064F

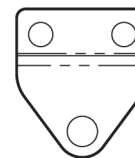

Rear Leaf Retainer - Outside x 2

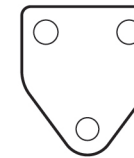

Rear Leaf Retainer - Inside x 2

12

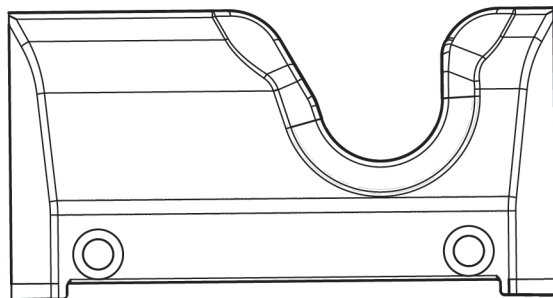

Front Center Skid Slider x 1
#BRX0290107F

13

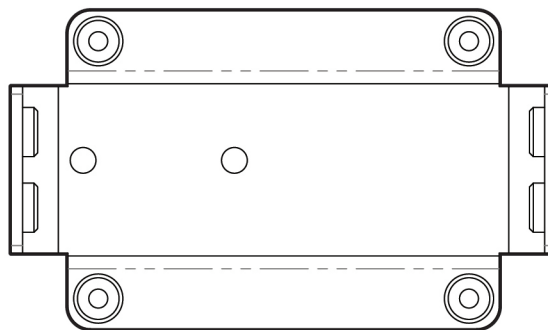

Center Skid Plate x 1
#BRX020020LF

14

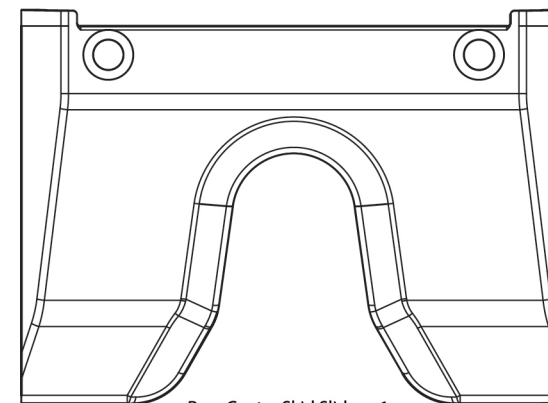

Rear Center Skid Slider x 1
#BRX0290107R

13

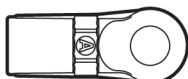

KUDU™ Nylon Rod End
(Straight 18.5mm) x 4
#BRW750306A



KUDU™ Nylon Rod End
(Straight 21.8mm) x 2
#BRW750309B



KUDU™ Nylon Rod End
19.5mm (Sideways) x 1
#BRW750308C



KUDU™ Nylon Rod End
(Upwards 20.0mm) x 1
#BRW750307D



BADASS™
Stainless Steel Pivot Ball x 8
#BRW750300



D2 Ball & Rod End x 1
#BRQ90351

15 **B LEAFS / SHOCKS**



M3x24 RS x 3
#BRASBH3024



M3x16 RS x 8
#BRASBH3016



M3x14 RS x 1
#BRASBH3014



M3x10 RS x 1
#BRASBH3010



M4x16 SS x 2
#BRASST4016



3x6x3
Tapper Spacer x 8
#BRLC7041



D4x7x1 Nylon Spacer x 2
#BRASSPD471/N



D6x1.5 O-Ring x 2
#BRORD6-15



M3 Nut - Nyloc x 1
#BRASNUTM3

15 **C LEAF SPRINGS**



M3x22 RS x 2
#BRASBH3022



M3x12 RS x 4
#BRASBH3012



M3 Nut - Nyloc x 20
#BRASNUTM3



M2.5 Nut x 2
#BRASNUTM25



M3x8 RS x 2
#BRASBH3008



M2.5x14 RS x 2
#BRASBH2514



D6x1.5 O-Ring x 8
#BRORD6-15



3x6x3
Tapper Spacer x 2
#BRLC7041

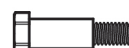

M3x14 Bolt x 12
#BRLC7064E



D4x7x1 Nylon Spacer x 4
#BRASSPD471/N

15 **A CHASSIS**



M3x14 RS x 4
#BRASBH3014/ST



M3x12 RS x 8
#BRASBH3012



M3x10 RS x 9
#BRASBH3010



M3x8 RS x 4
#BRASBH3008



M3x6 RS x 2
#BRASBH3006



M2.5x4 RS x 8
#BRASBH2504



M3x10 CSS x 28
#BRASFH3010



M3x6 CSS x 4
#BRASFH3006



M2x4 SC x 4
#BRASCH2004



M3x4 SS x 2
#BRASST3004



M3x3 SS x 4
#BRASST3003



M3 Nut - Nyloc x 4
#BRASNUTM3



M3x5 Hex Cap Screw x 2
#BRASHS3005

15 **D WHEELS**



M4 Nuts - Nyloc x 4
#BRASNUTM4



D4x7x2
Steel Spacer x 4
#BRASSP472



D2x10 Pin x 4
#BRASPIN210

16

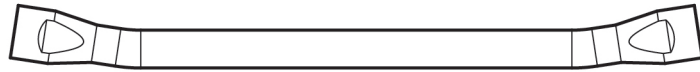

Stainless Steel Tie Rod x 1
#BRD8022A

17

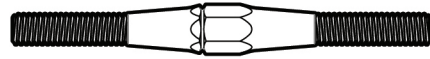

Fine Tunable Link - 55mm x 1
#BRLC7050

18

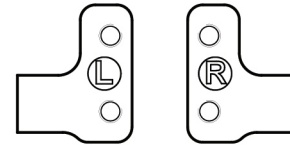

Steering Servo Mount x 2
#BRX020108

19



Body Latch Pin x 4
#BRX020034

20

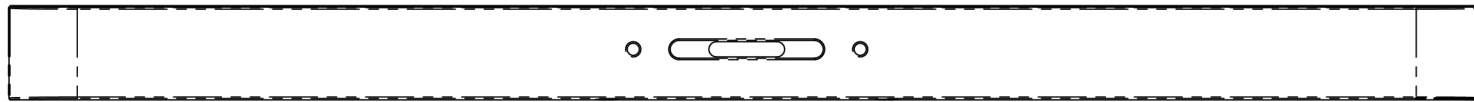

Front Bumper x 1
#BRX020109F

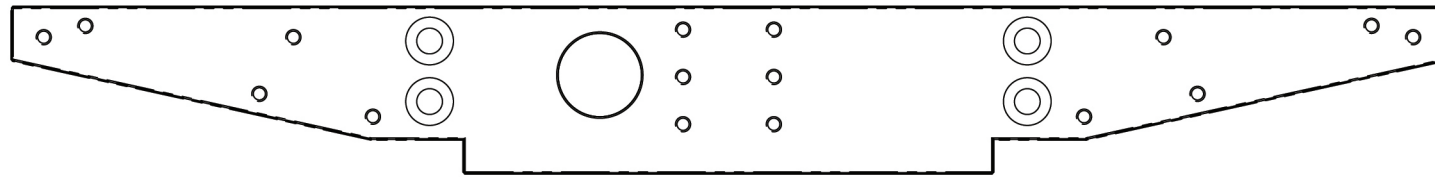

Rear Bumper x 1
#BRX020109R

21

#BRX020018F

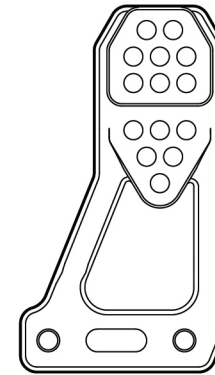

Front Shock Mount - Left x 1

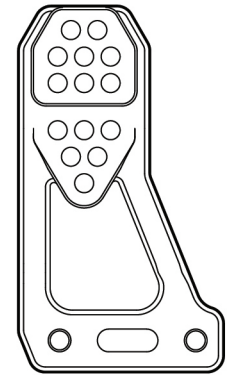

Front Shock Mount - Right x 1

22

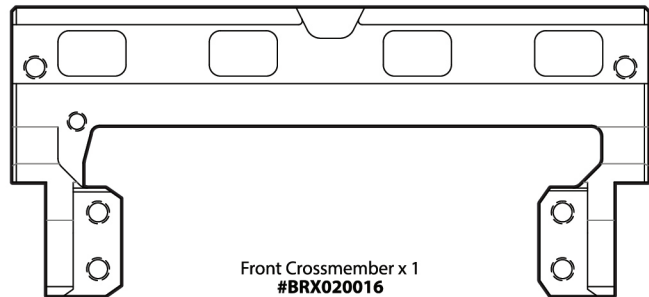

Front Crossmember x 1
#BRX020016

23

#BRX020110

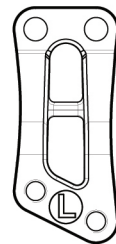

Side Gearbox Mount
- Left x 1

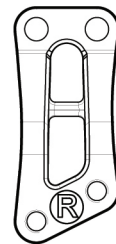

Side Gearbox Mount
- Right x 1

24



D3x6x9 Spacer x 2
#BRX0290016

25

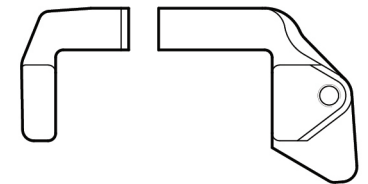

Mini Servo Mount x 1
#BRX0290012

26

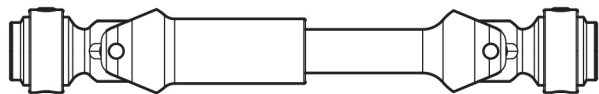

KUDU™ HD CVD Front Center Drive Shaft x 1
#BRX029043

28

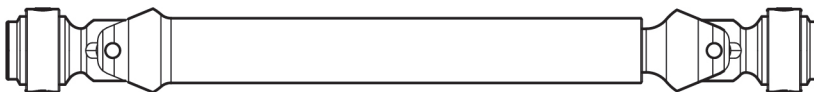

KUDU™ HD CVD Rear Center Drive Shaft x 1
#BRX029043

27

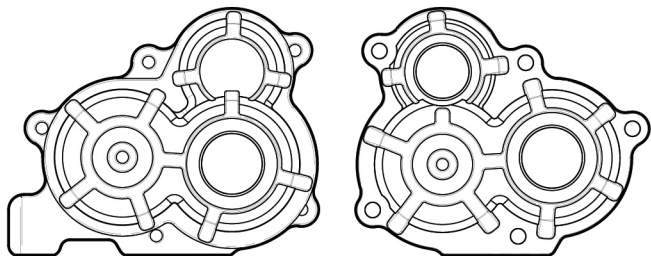

B2X™ Transfer Case Housing x 1
#BRX020111

29

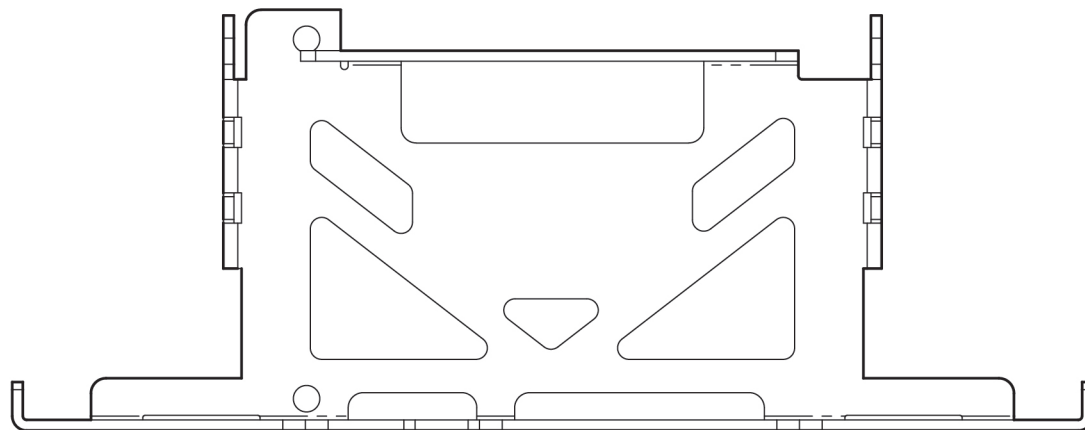

Battery Tray x 1
#BRX029021

31

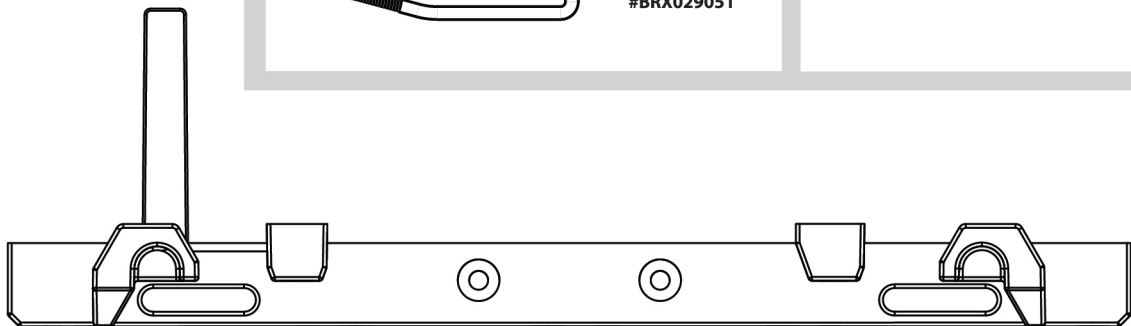

Aluminum Body Brace
⚠ (Provided with Series Land Rover Body Kit)

30



Shift Rod x 1
#BRX029051

#BRX020112

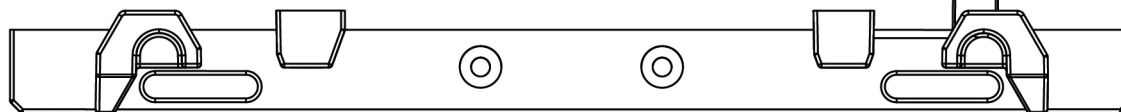

34

#BRX020113



Rear Bumper Guard x 2

32

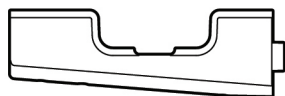

Body Post x 4
#BRX020039

33



Quick Release Body Latch x 2
#BRX020061

35



Mid Crossmember x 1
#BRX020014

36



Rear Crossmember x 1
#BRX020012

39

#BRX029019

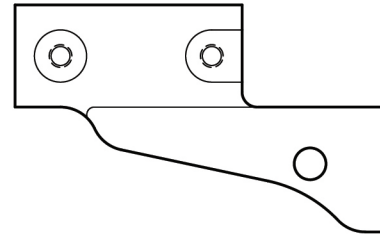

Rear Bumper Mount - Left x 1

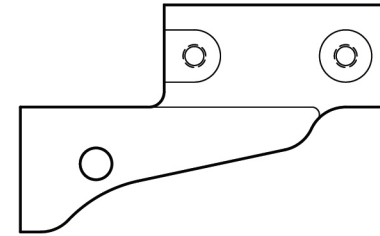

Rear Bumper Mount - Right x 1

37

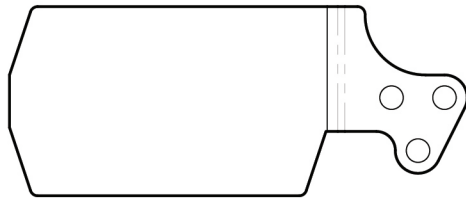

ESC Mount Bracket
#BRX020106

40

#BRLC7033

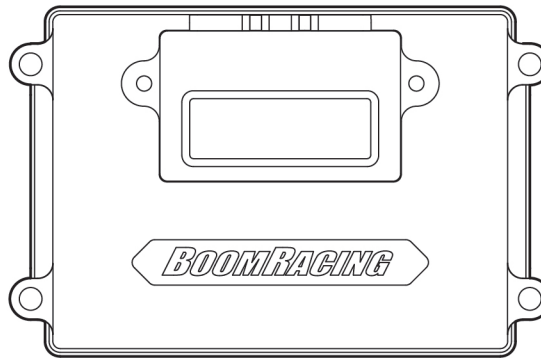

Receiver Box Lid x 1



Stainless Steel Sealing Plate x 1

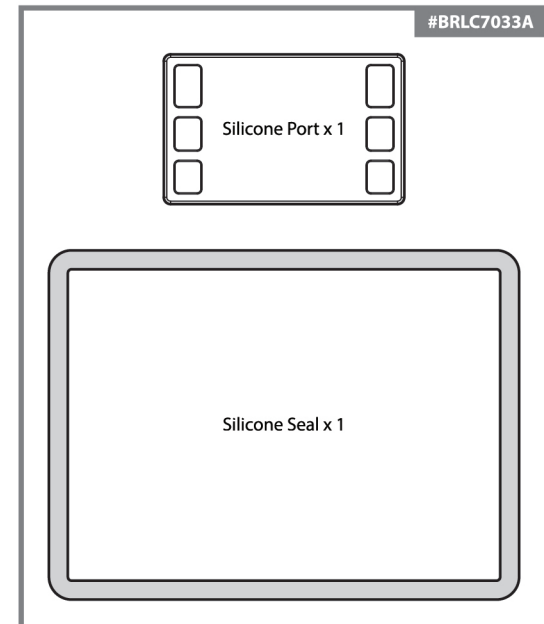

Receiver Box x 1

#BRLC7033A

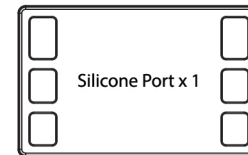

Silicone Port x 1

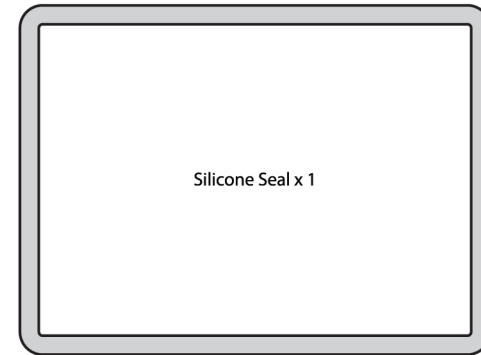

Silicone Seal x 1

38

#BRX020018R

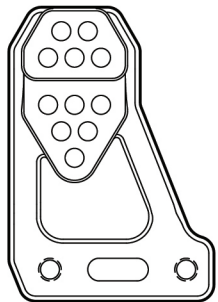

Rear Shock Mount - Left x 1

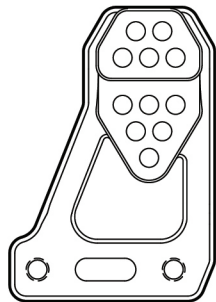

Rear Shock Mount - Right x 1

41

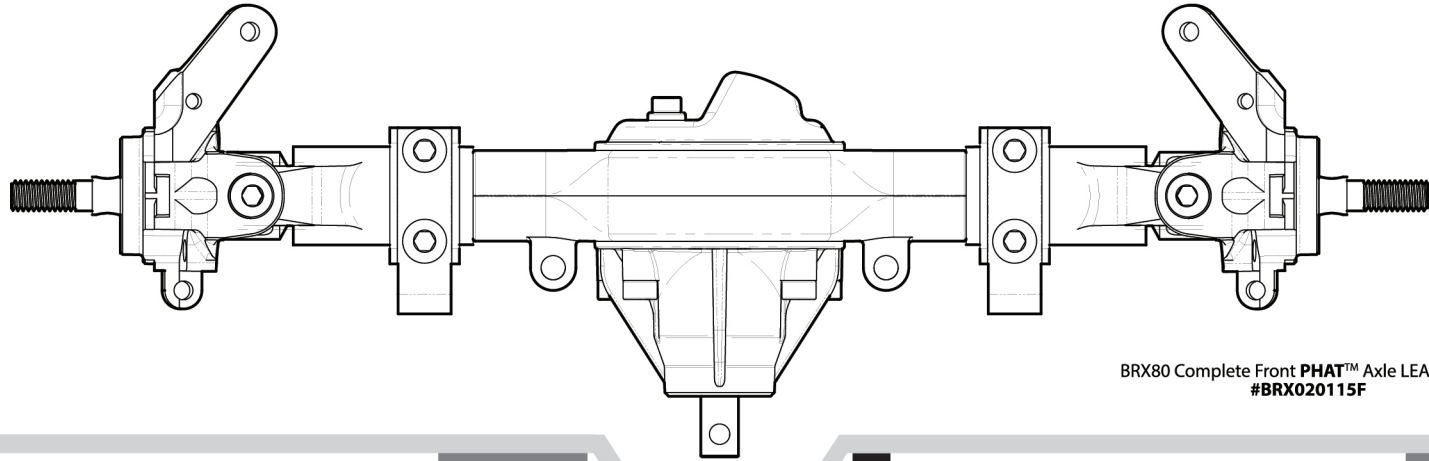

BRX80 Complete Front **PHAT™** Axle LEAF Ver. x 1
#BRX020115F

45

#BRW780944

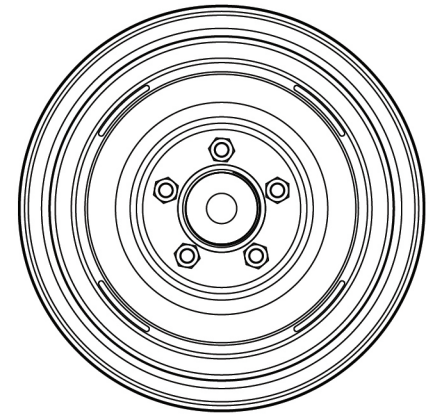

SLR™ 1.9 Classic Steel Wheel x 4
w/ Cap and Scale Hardware

42

BCF2™ Gearbox Housing (2pcs)

#BRX020029

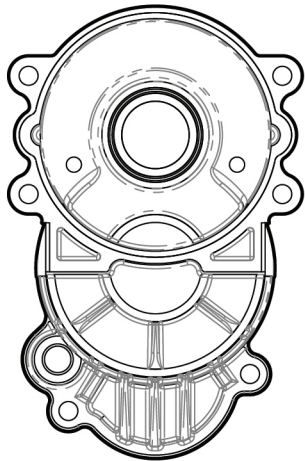

Gearbox Housing A

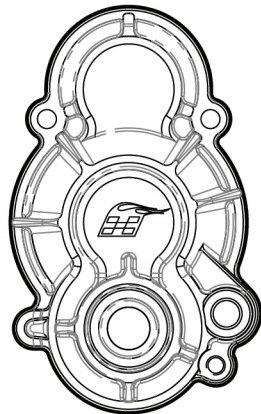

Gearbox Housing B

43

#BRLC7027

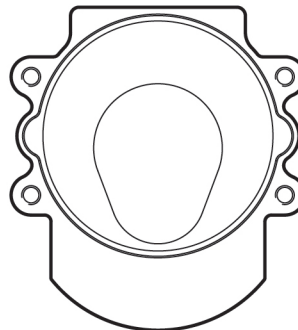

Gearbox Adapter x 1

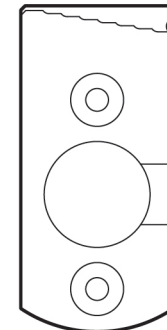

Motor Mount x 1

44

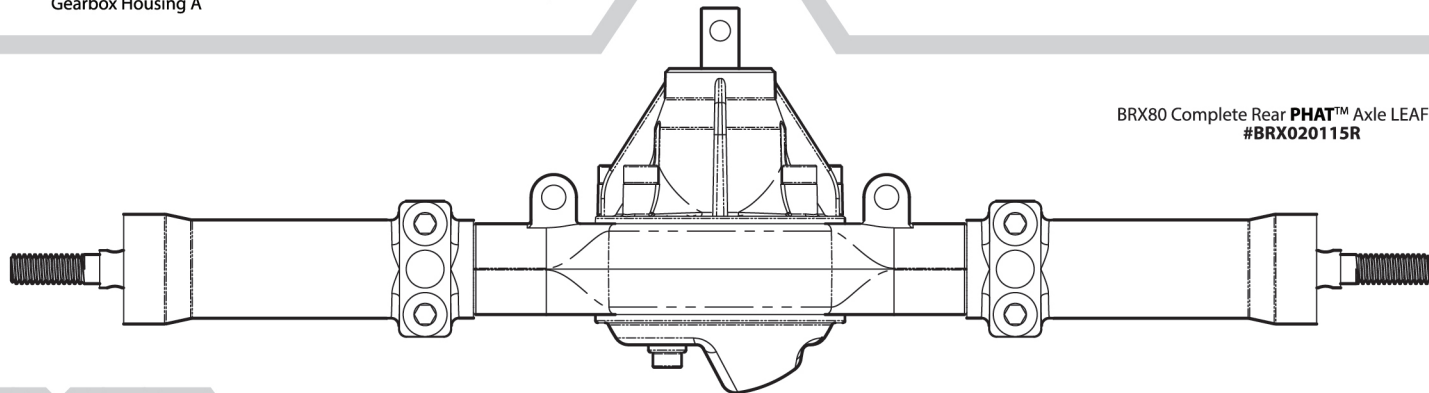

BRX80 Complete Rear **PHAT™** Axle LEAF Ver. x 1
#BRX020115R



Wheel Caps installation Tool x 1
#BRW780944D

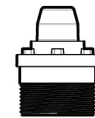

Nylon Wheel Caps x 4
#BRW780944C

45

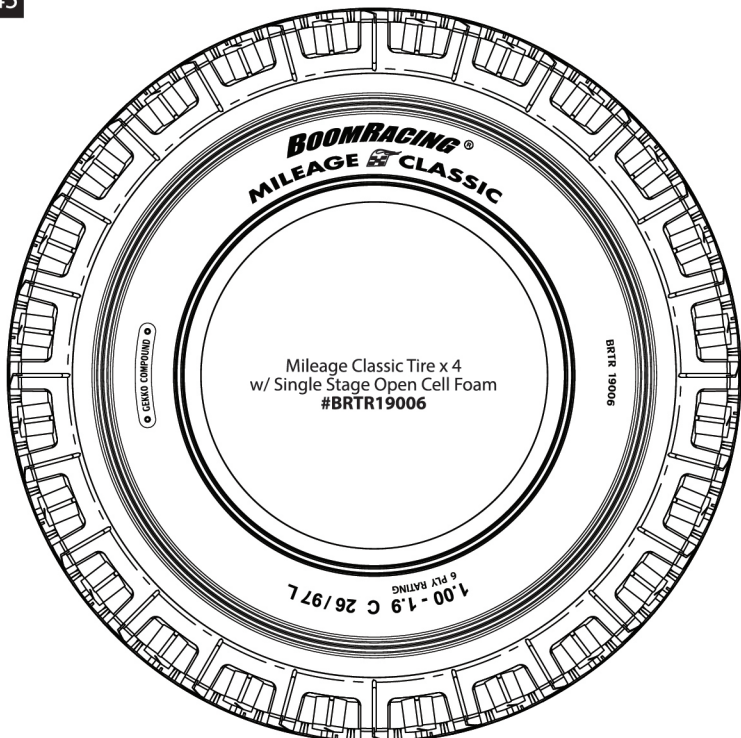

46

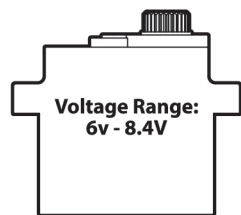

JX Waterproof HV Mini Servo x 1
#JX/PDI-HV1151MG

47

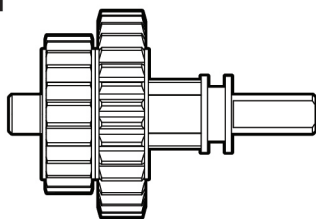

2-Speed Gear Unit x 1
#BRLC7044E



Spur Gear Mount x 1
#BRLC7030

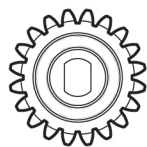

Spur Gear 20T x 2
#BRLC7029-20T

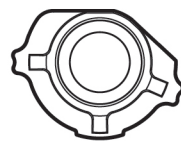

Bearing Holder x 1
#BRX020029A

47 **E** GEARBOX / TRANSFER CASE

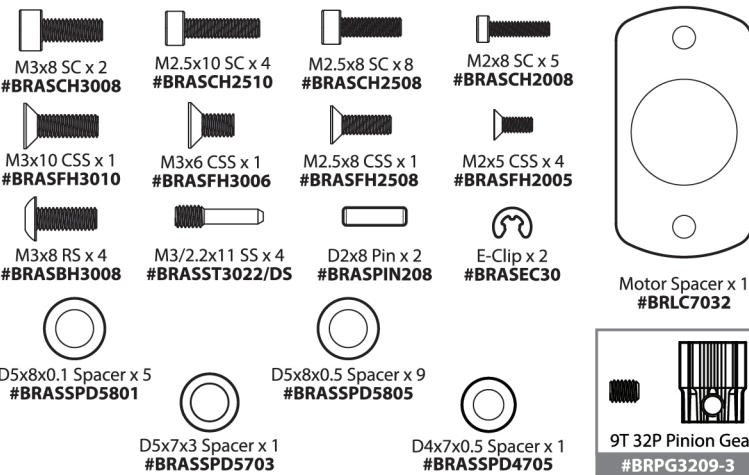

47 **F** RECEIVER BOX

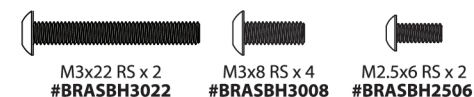

47 **G** BODY MOUNTS

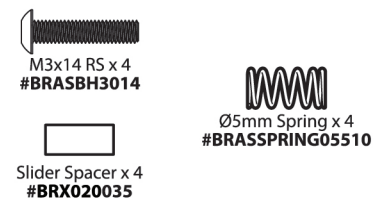

47 **H** SERVOS

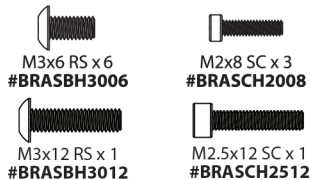
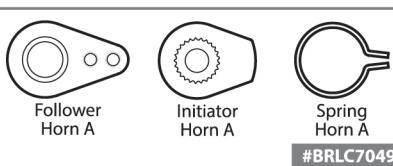

47 **I** GEARS, SHAFTS & BEARINGS - TRANSFER CASE

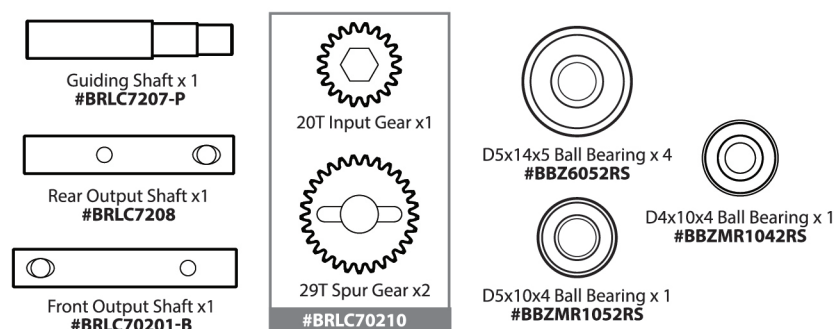

47 **J** GEARS, SHAFTS & BEARINGS - GEAR BOX

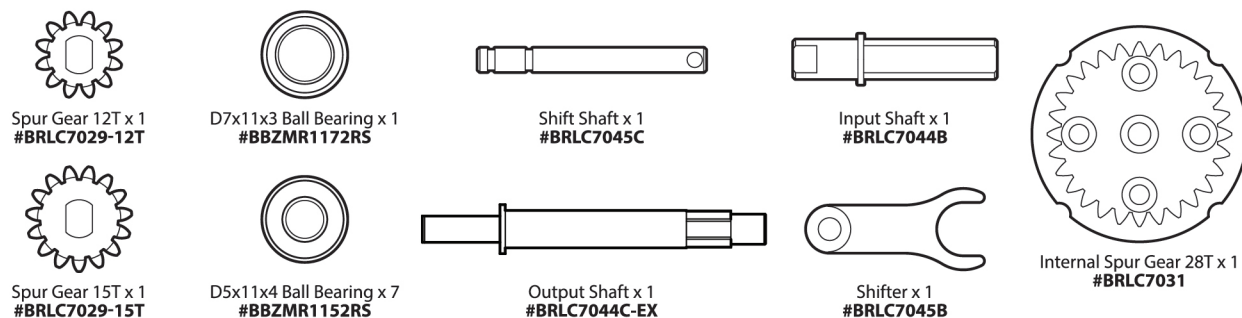

47



Extension Cable x 2
#BRLC7059

47

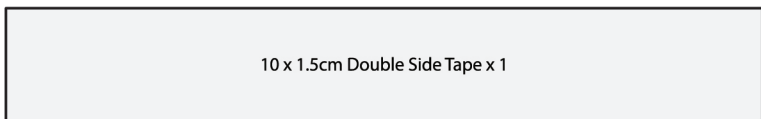

10 x 1.5cm Double Side Tape x 1



47

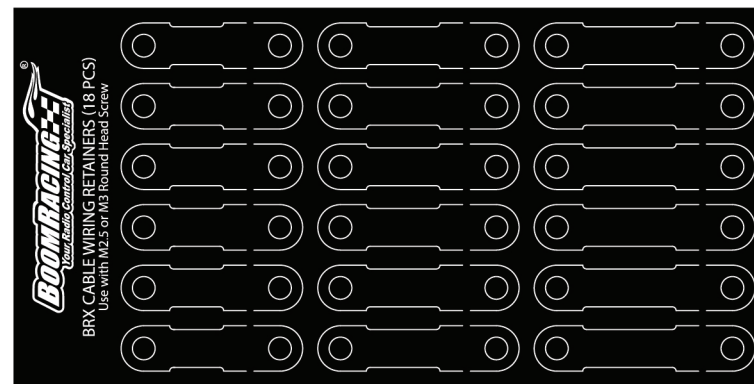

BOOMRACING
Your Radio Control Car Specialist
BRX CABLE WIRING RETAINERS (18 PCS)
Use with M2.5 or M3 Round Head Screw

Cable Wiring Retainers
#BRT10037

47

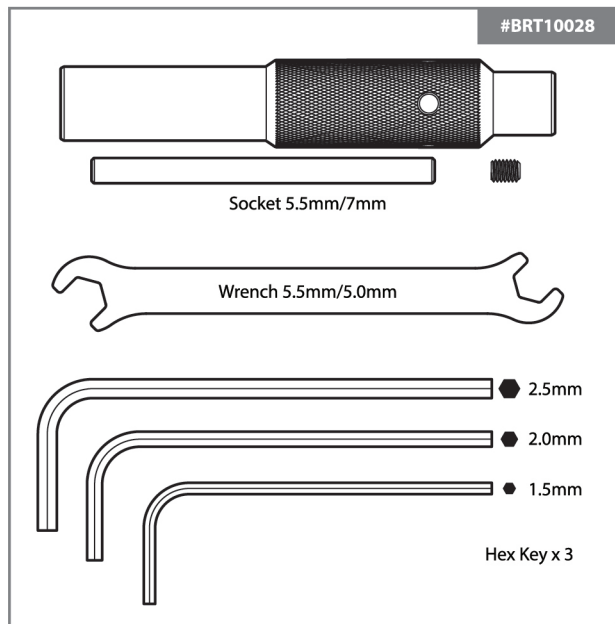

#BRT10028

Socket 5.5mm/7mm

Wrench 5.5mm/5.0mm

2.5mm

2.0mm

1.5mm

Hex Key x 3

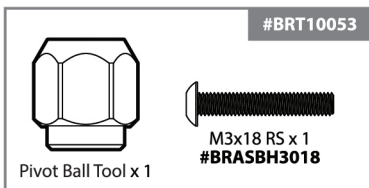

#BRT10053

Pivot Ball Tool x 1

M3x18 RS x 1
#BRASBH3018

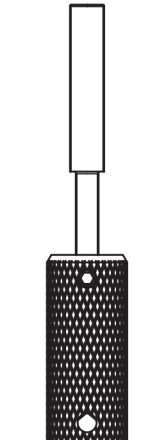

3.0mm Scale Socket
Thumb Driver x 1
#BRPROB-17

47

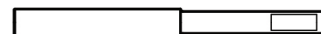

2.0mm Socket Driver Bit X 1



M2x9 Scale Hex Bolt x 4
#BRPROB-06BK

47



Black Graphite Grease 10g x 1
#BRGRS1055-10

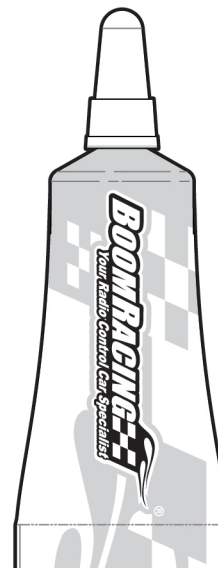

Silicone Grease 10g x 1
#BRGRS10274-10



30WT Shock Oil 15ml x 1
(Available separately in 60ml)
#BRSHK030



242 Thread Lock 2g x 1
(Available separately in 10g)
#BRGRS242



1- CHASSIS RAIL

Parts Needed:



Body Latch Pin x 4
#BRX020034

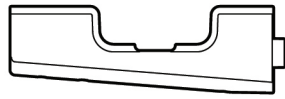

Body Post x 4
#BRX020039

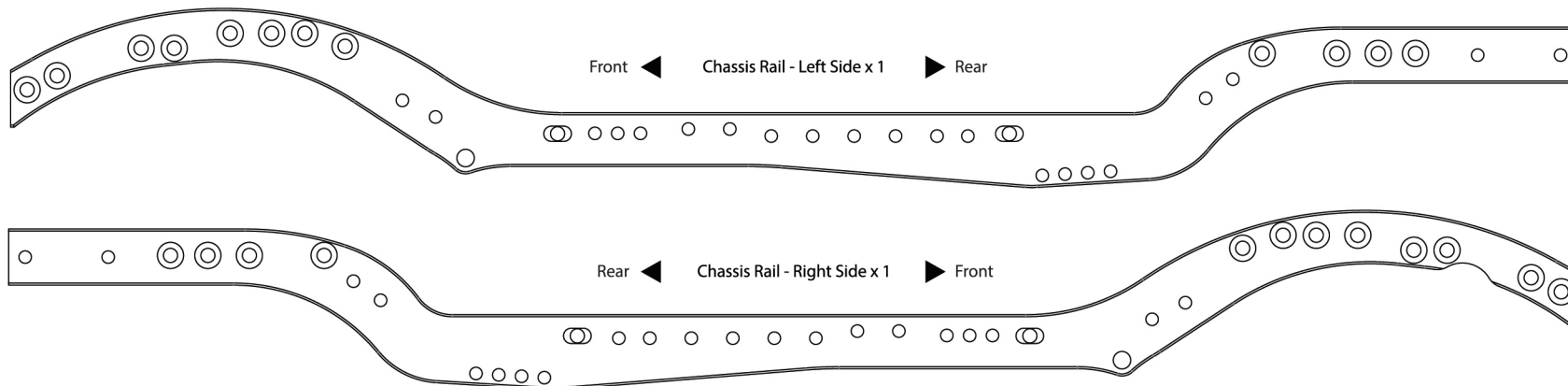
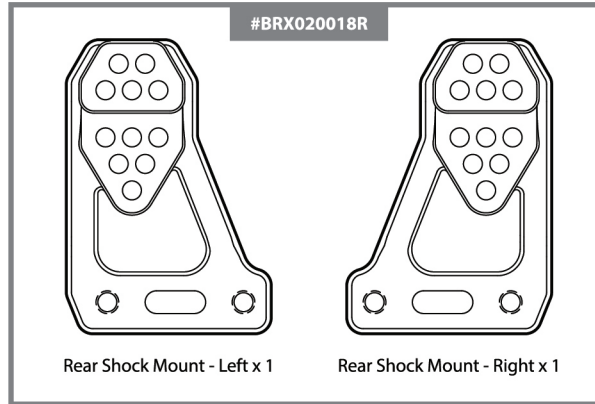
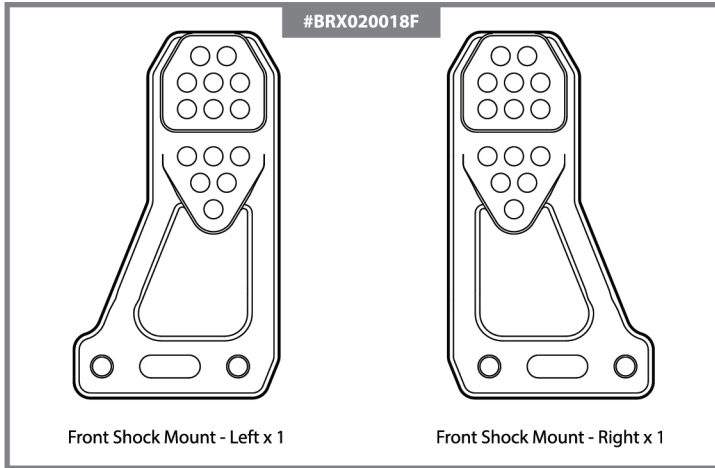
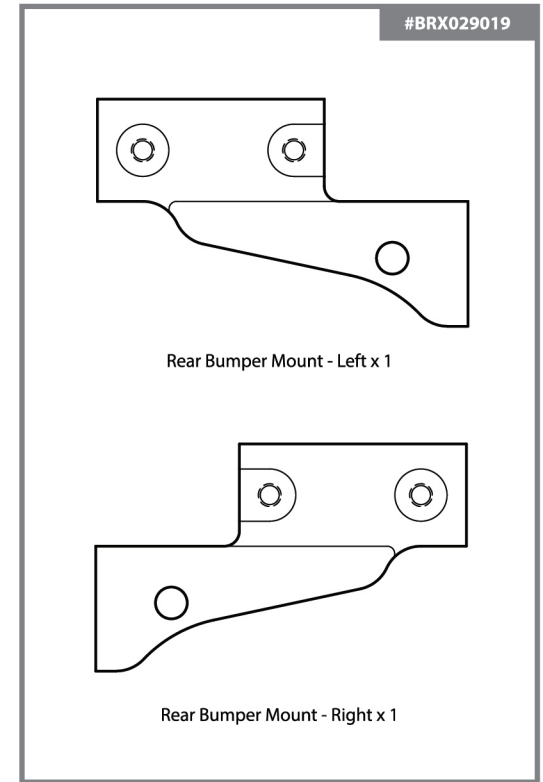
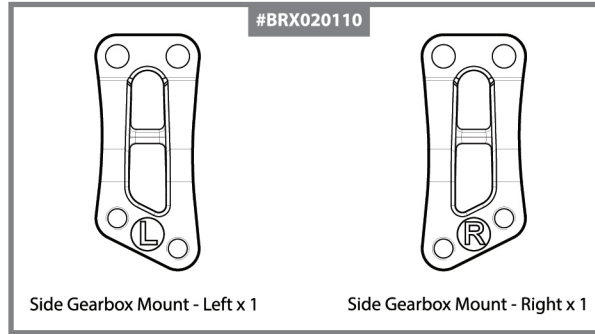

#BRX0290011





CHASSIS RAIL

CHASSIS RAIL

A CHASSIS



Apply Thread Lock to all screws.
(Do Not Use Red Loctite)

-  M3x10 RS x 4
#BRASBH3010
-  M3x8 RS x 4
#BRASBH3008
-  M3x10 CSS x 12
#BRASFH3010
-  M3x3 SS x 4
#BRASST3003

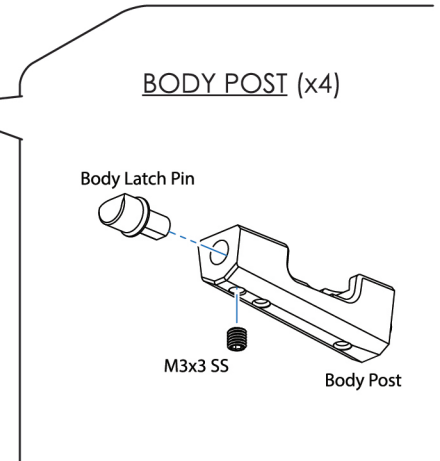
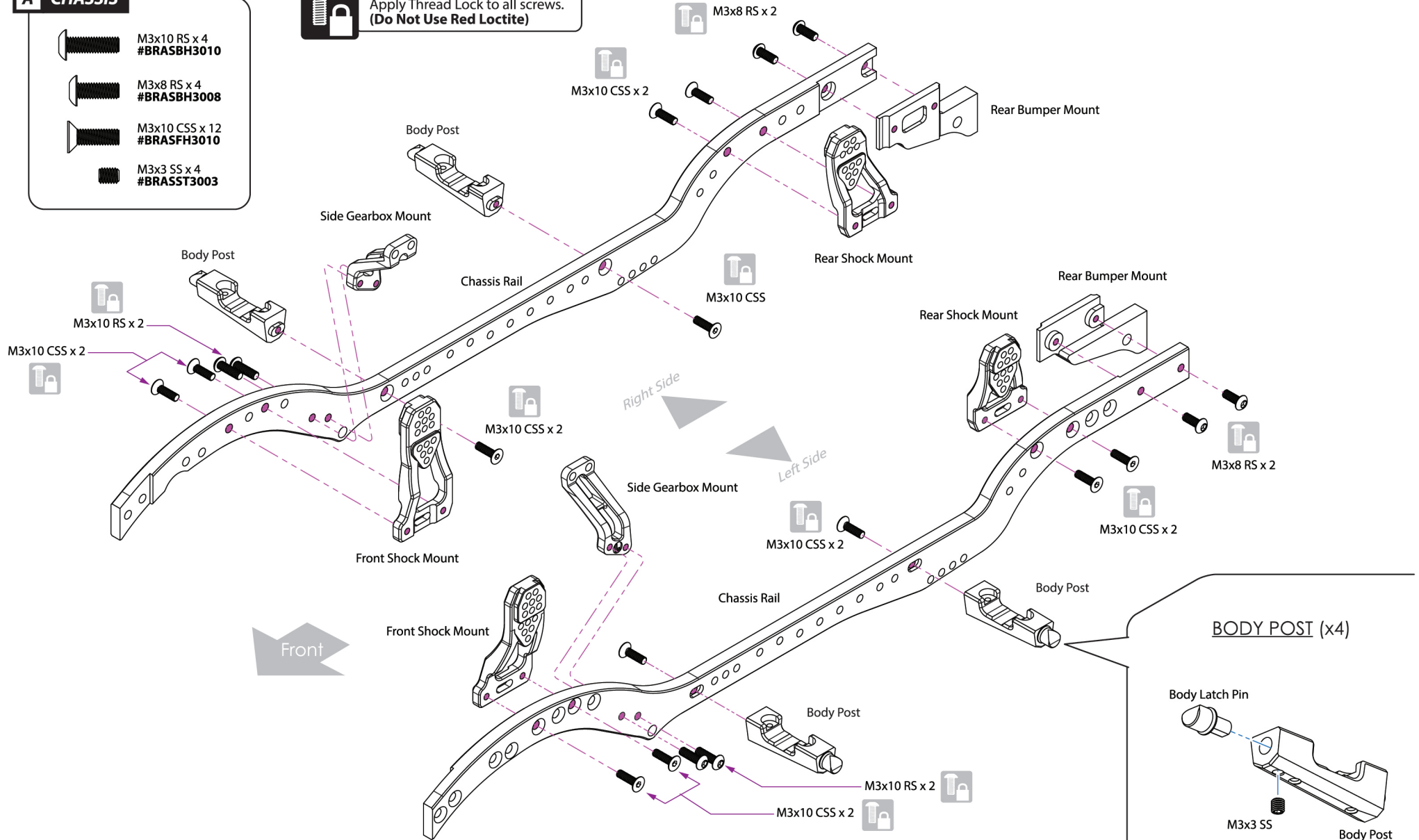

2 - CHASSIS

Parts Needed:

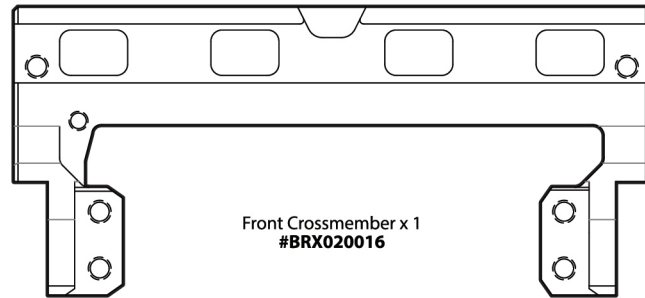

Front Crossmember x 1
#BRX020016

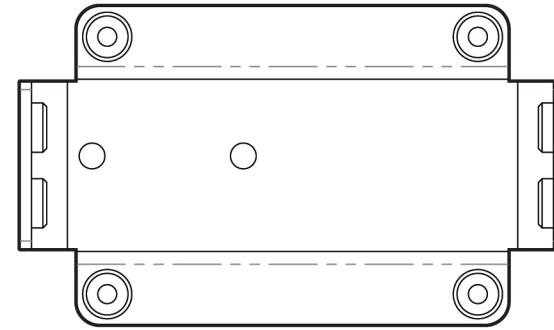

Center Skid Plate x 1
#BRX020020LF



Mid Crossmember x 1
#BRX020014

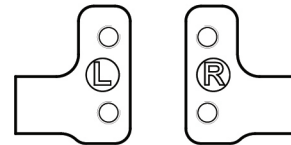

Steering Servo Mount x 2
#BRX020108

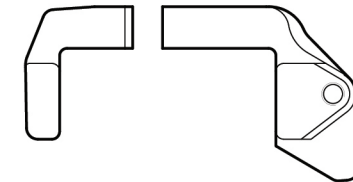

Mini servo Mount x 1
#BRX0290012

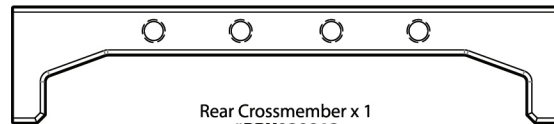

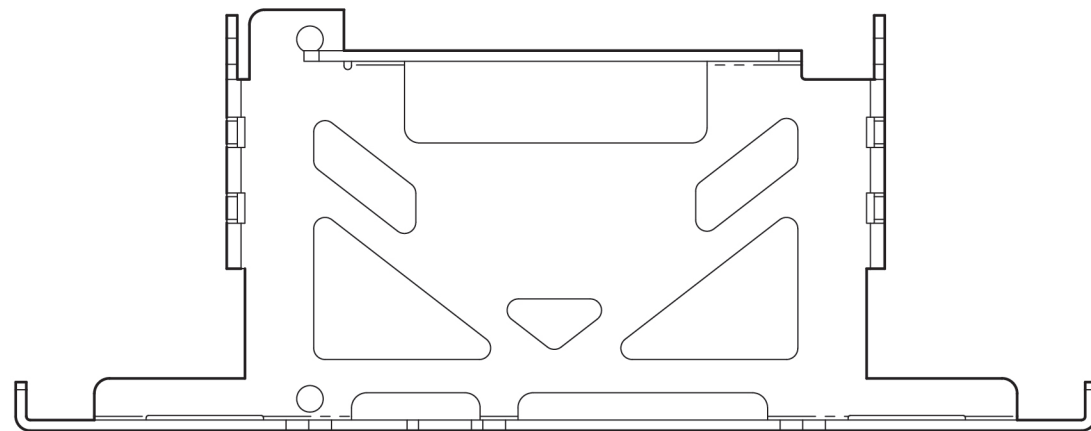

Rear Crossmember x 1
#BRX020012



Battery Tray x 1
#BRX029021

A CHASSIS

-  M3x12 RS x 4
#BRASBH3012
-  M3x10 RS x 4
#BRASBH3010
-  M3x10 CSS x 8
#BRASFH3010

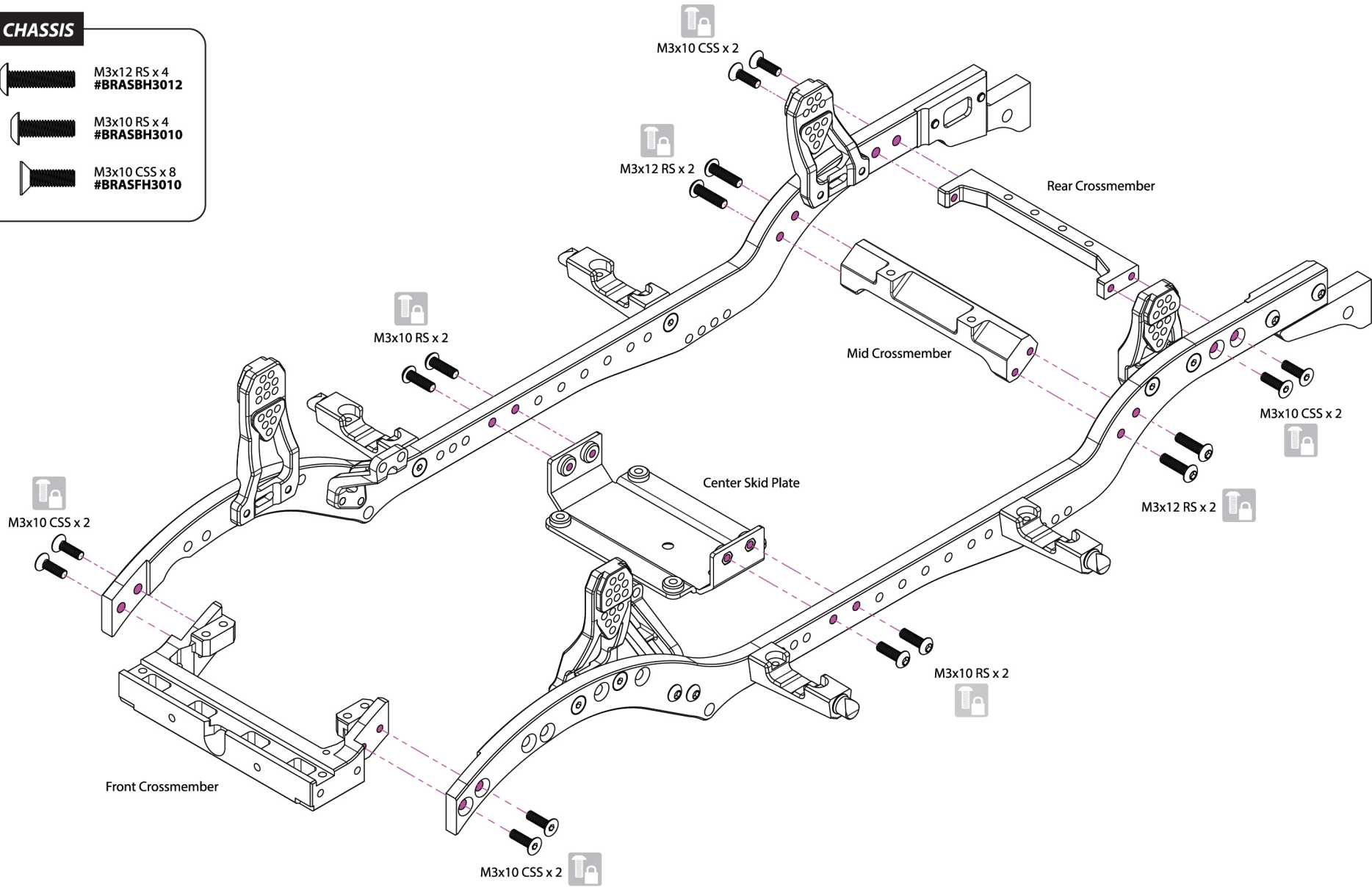

A CHASSIS

 M3x10 CSS x 4
 #BRASFH3010

 M3x12 RS x 2
 #BRASBH3012

 M3 Nut - Nyloc x 2
 #BRASNUTM3

Hard case battery with size 139x47x25mm is ideal for the battery tray. We recommend using self-adhesive velcro tape for the battery pack.

 M3x12 RS x 2

M3 Nut x 2

M3x10 CSS x 4

Servo Mount x 2

Battery Tray



Bend both tabs as shown to install the optional winch mount.

The battery tray is designed to fit a standard size servo winch if you wish to install one. A smaller sized battery pack is required to provide enough space to do so (maximum 95x47x25mm).

3 - BUMPERS

Parts Needed:

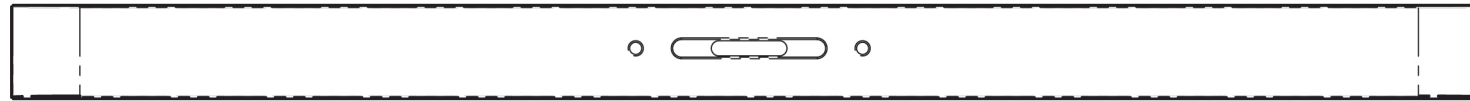

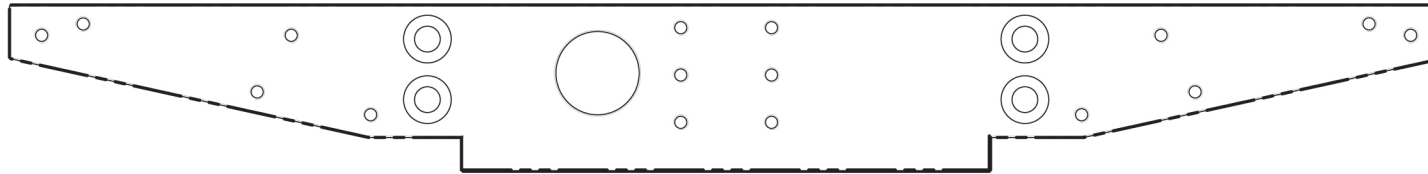

Front Bumper x 1
#BRX020109F



Rear Bumper x 1
#BRX020109R

A CHASSIS

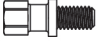
-  M3x10 CSS x 4
#BRASFH3010
-  M3x4 SS x 2
-  M3x5 Hex Cap Screw x 2
#BRASH53005

FRONT BUMPER

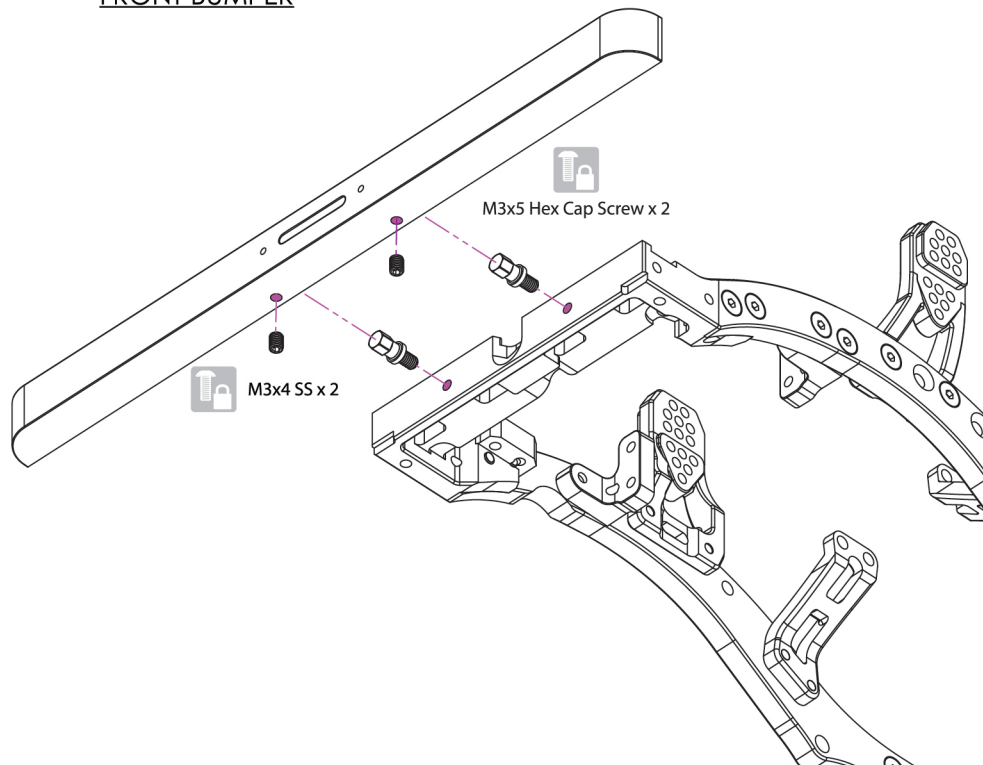

REAR BUMPER

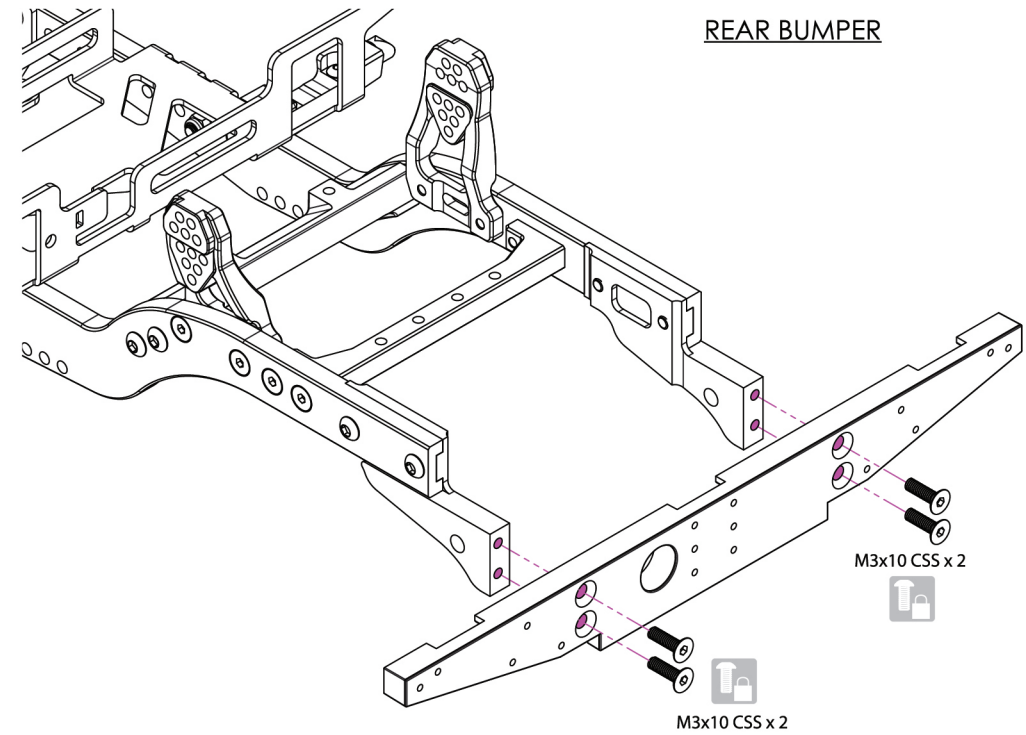

BUMPERS

BUMPERS

4 - GEARBOX / TRANSFER CASE

Parts Needed:

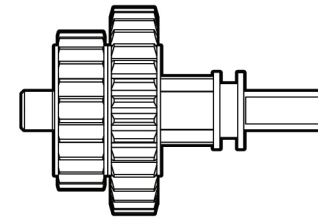
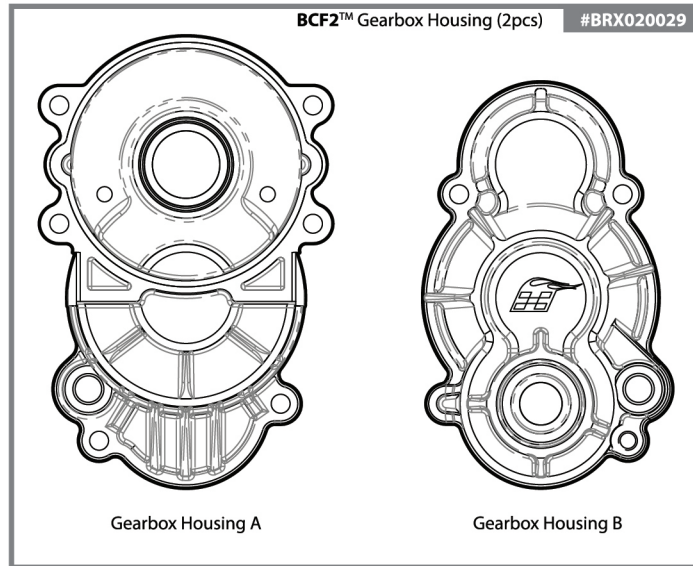

2-Speed Gear Unit x 1
#BRLC7044E

J GEARS, SHAFTS & BEARINGS - GEAR BOX

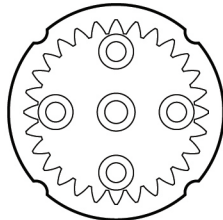

Internal Spur Gear 28T x 1
#BRLC7031

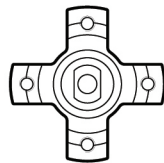

Spur Gear Mount x 1
#BRLC7030



Spur Gear 12T x 1
#BRLC7029-12T

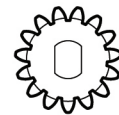

Spur Gear 15T x 1
#BRLC7029-15T

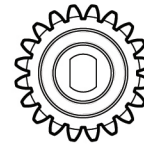

Spur Gear 20T x 2
#BRLC7029-20T



D5x11x4 Ball Bearing x 7
#BBZMR1152RS



D7x11x3 Ball Bearing x 1
#BBZMR1172RS

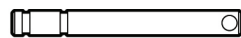

Shift Shaft x 1
#BRLC7045C

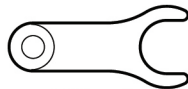

Shifter x 1
#BRLC7045B



Input Shaft x 1
#BRLC7044B

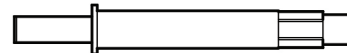

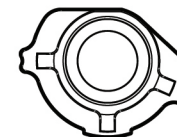

Output Shaft x 1
#BRLC7044C-EX



Bearing Holder x 1
#BRX020029A

4.1

E GEARBOX / TRANSFER CASE

-  M2.5x8 CSS x 1
#BRASFH2508
-  M2x5 CSS x 4
#BRASFH2005

 Fit the Spur Gear Mount onto the Spur Gear by tightening M2x5 countersunk screws.

To install or remove the spur gear from the gearbox, align the spur gear as pictured and temporarily insert two M3 screws** to act as stoppers.

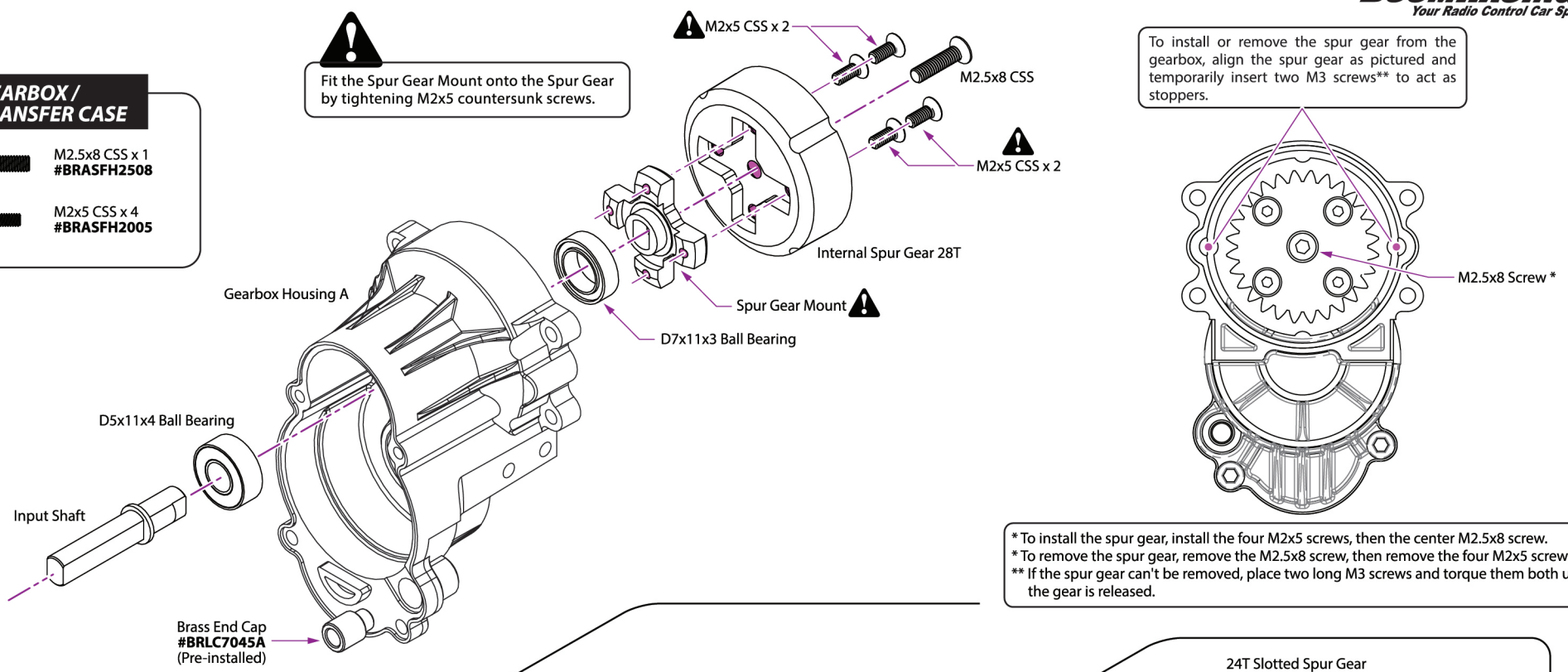

*To install the spur gear, install the four M2x5 screws, then the center M2.5x8 screw.
*To remove the spur gear, remove the M2.5x8 screw, then remove the four M2x5 screws.
** If the spur gear can't be removed, place two long M3 screws and torque them both until the gear is released.

4.2

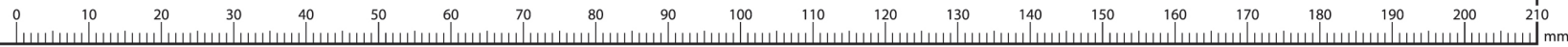
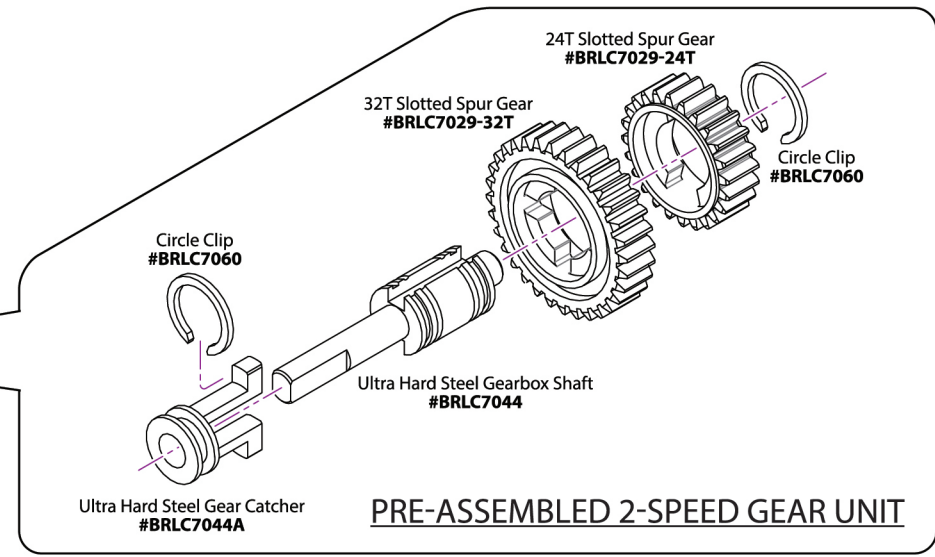
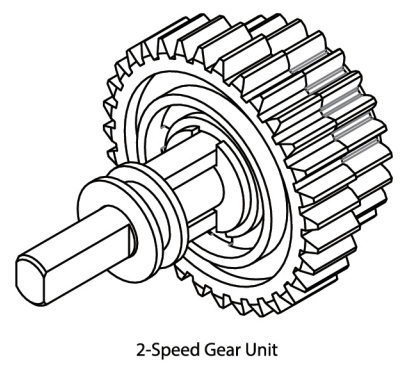



GEARBOX

GEARBOX

4.3

E GEARBOX / TRANSFER CASE

-  D5x8x0.5 Spacer x 3
#BRASSPD5805
-  M3 E-Clip x 2
#BRASEC30
-  D5x8x0.1 Spacer x 4
#BRASSPD5801

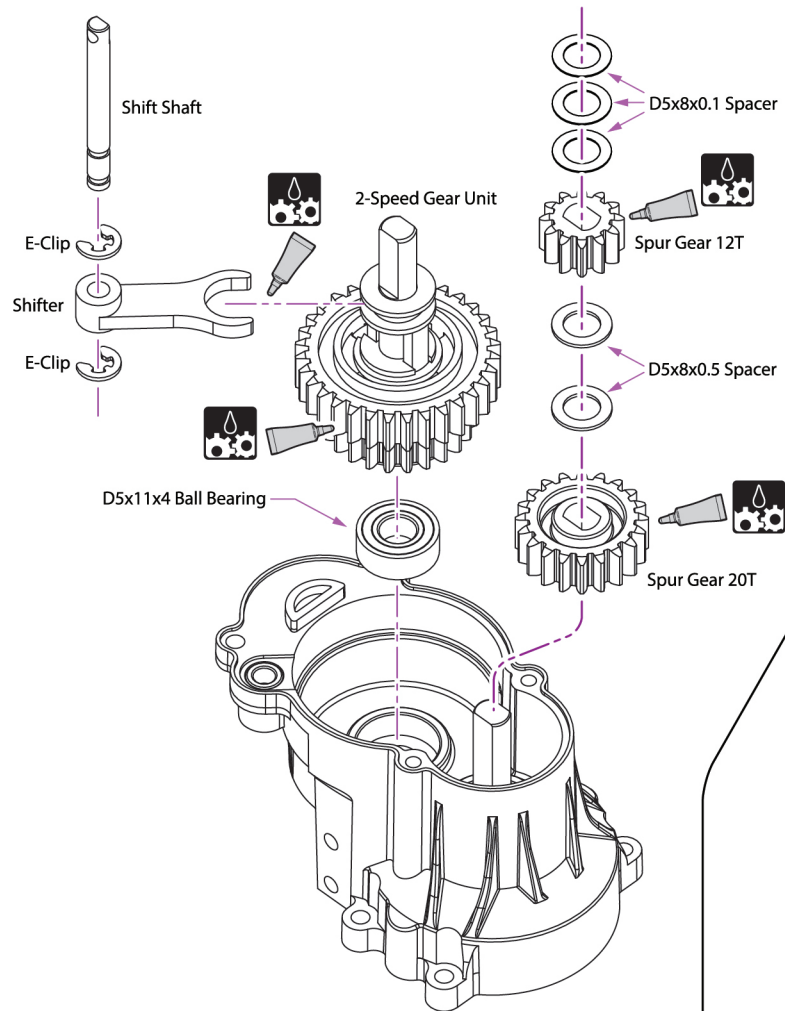

E GEARBOX / TRANSFER CASE

-  M2.5x10 SC x 4
#BRASCH2510

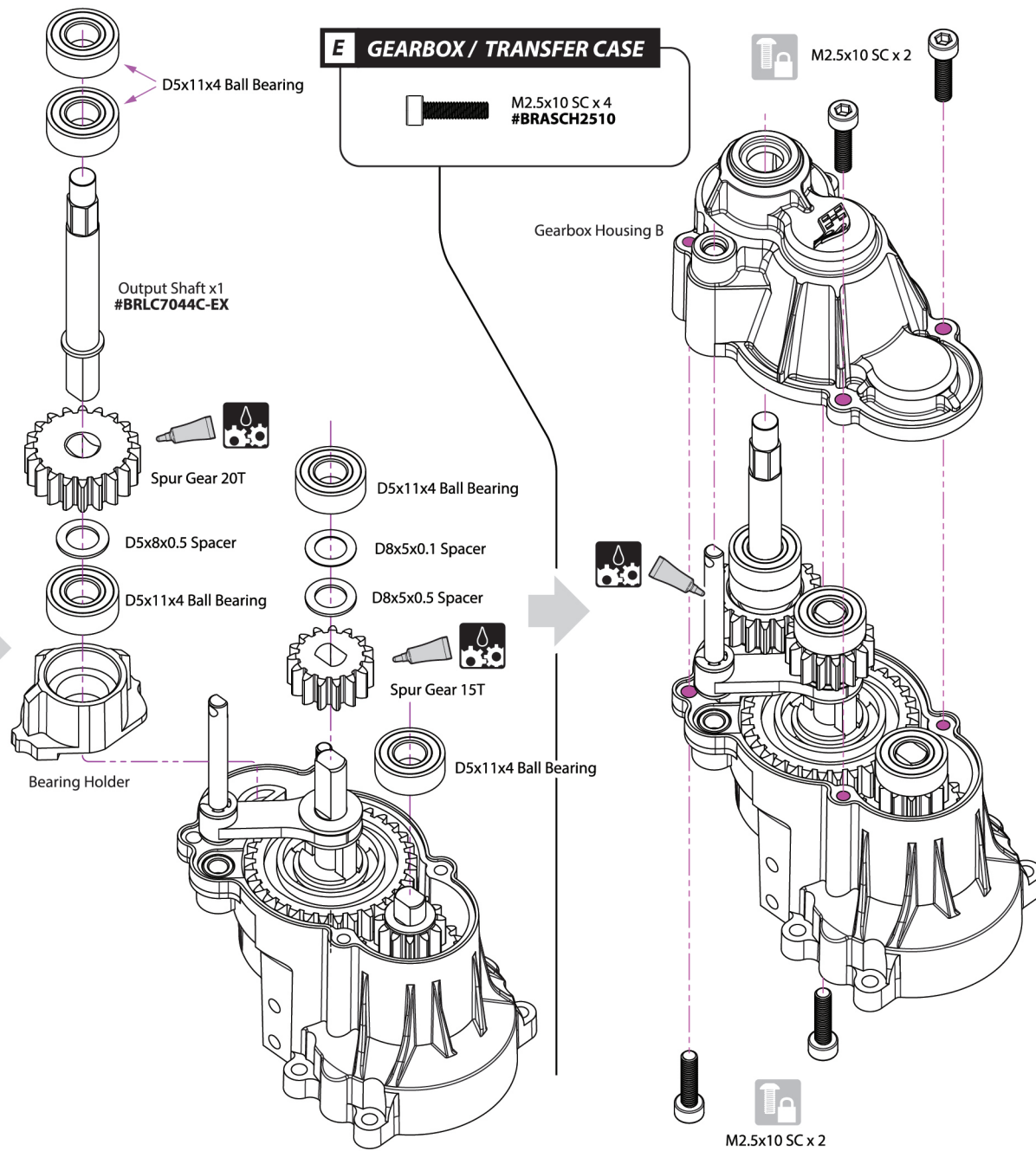

GEARBOX

GEARBOX

5 - TRANSFER CASE

Parts Needed:

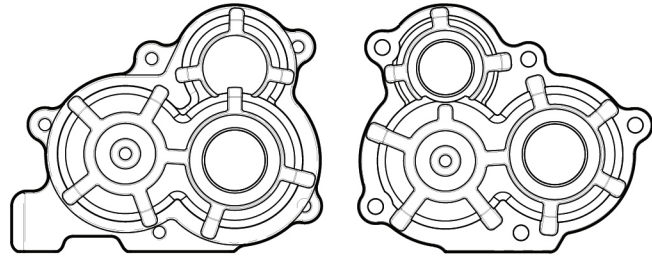

B2X™ Transfer Case Housing
#BRX020111

E GEARBOX / TRANSFER CASE

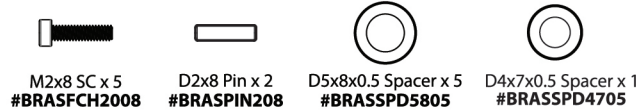

I GEARS, SHAFTS & BEARINGS - TRANSFER CASE

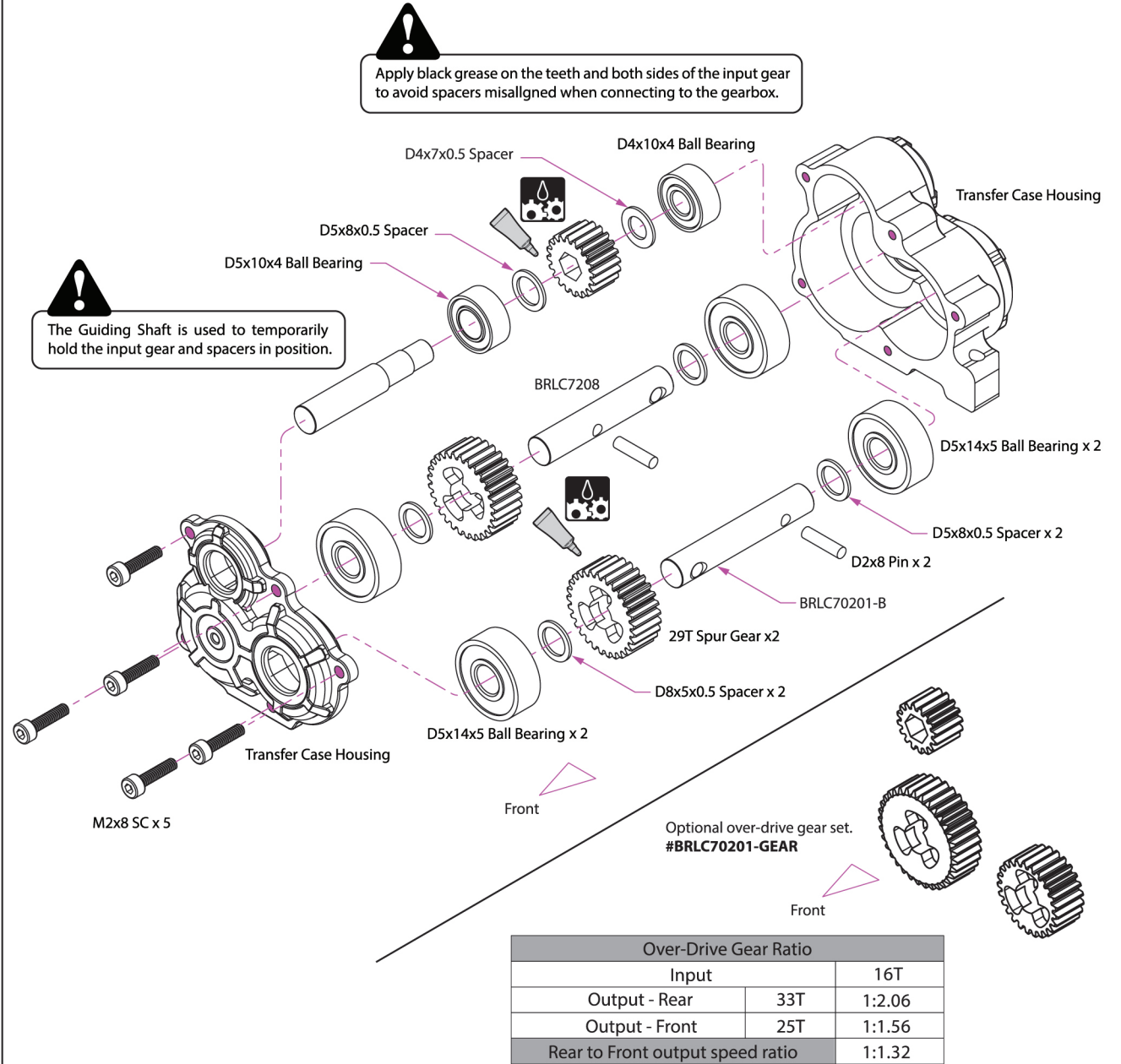
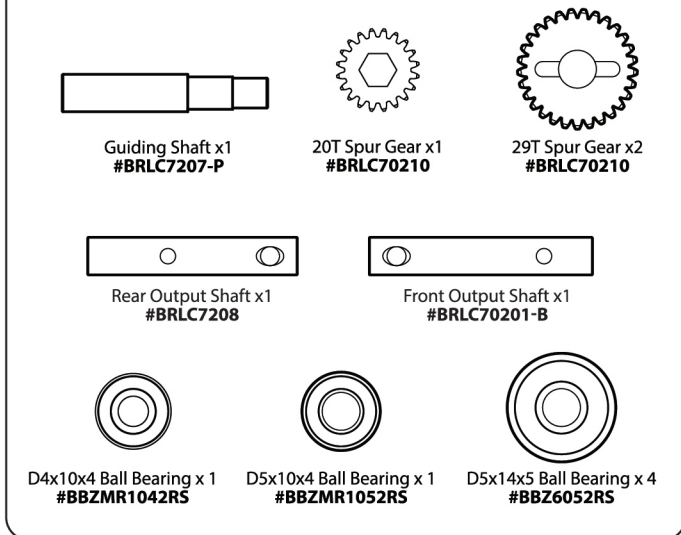

Over-Drive Gear Ratio		
Input		16T
Output - Rear	33T	1:2.06
Output - Front	25T	1:1.56
Rear to Front output speed ratio		1:1.32

TRANSFER CASE

TRANSFER CASE

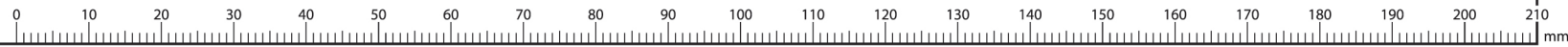

5 - TRANSFER CASE

Parts Needed:

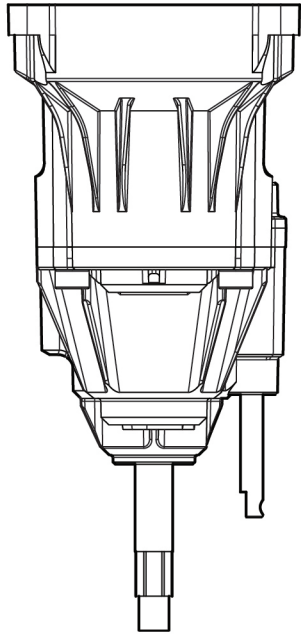

Complete **BCF2™** Gearbox

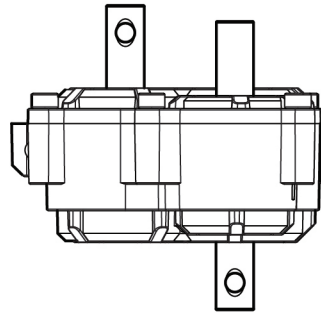

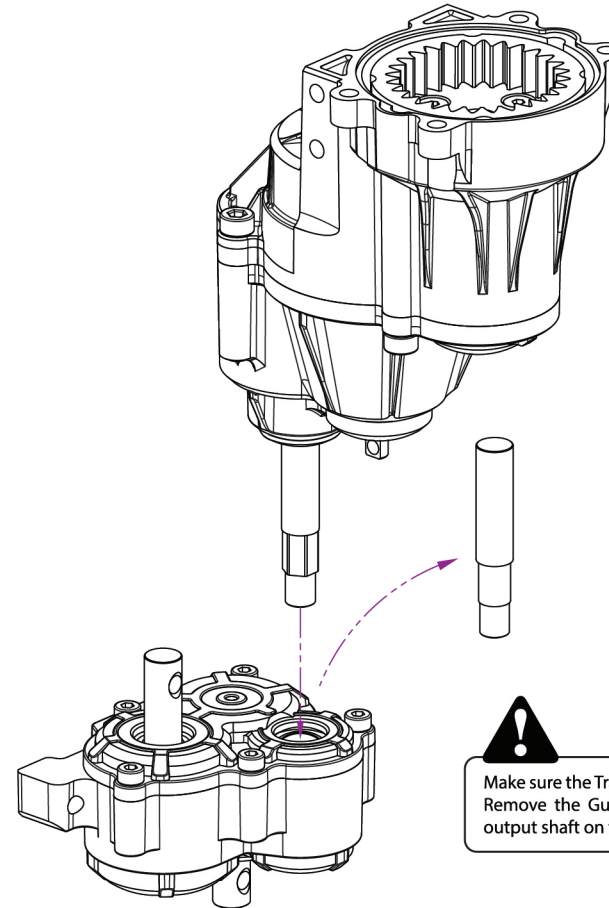

Complete **B2X™** Transfer Case



Make sure the Transfer Case is kept in the upwards position. Remove the Guiding Shaft carefully and then insert the output shaft on the Gearbox into the Transfer Case.

6 - TRANSMISSION

E GEARBOX / TRANSFER CASE

-  M3x8 RS x 4
#BRASBH3008
-  M3x10 CSS x 1
#BRASFH3010
-  M3x6 CSS x 1
#BRASFH3006

Complete BCF2™ Gearbox

Complete OD Ready
Transfer Case

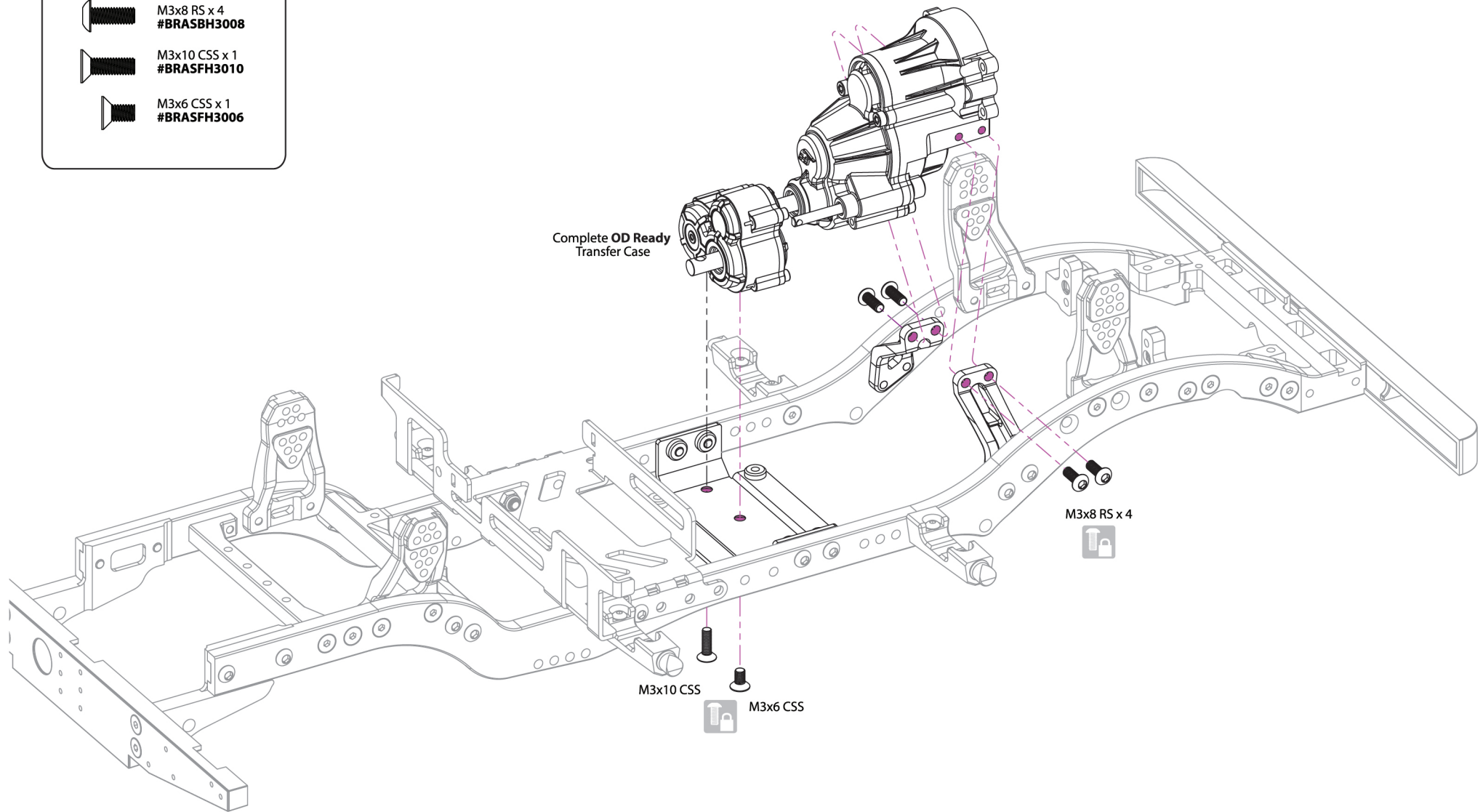

TRANSMISSION

TRANSMISSION

BRX02



7 - FRONT AXLE & LEAF SPRING

Parts Needed:

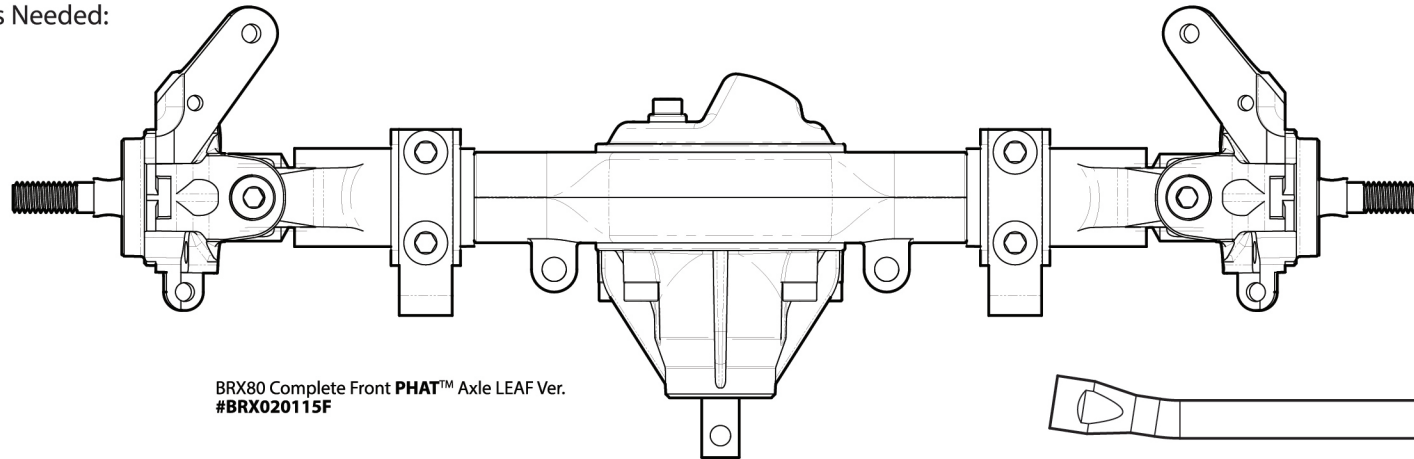

BRX80 Complete Front PHAT™ Axle LEAF Ver.
#BRX020115F

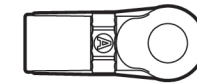

KUDU™
Nylon Rod End
(Straight 18.5mm) x 2
#BRW750306A



BADASS™
Stainless Steel Pivot Ball x 2
#BRW750300

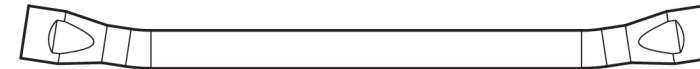

Stainless Steel Tie Rod x 1
#BRD8022A

B LEAFS / SHOCKS

M4x16 SS x 2
#BRASST4016

D4x7x1
Nylon Spacer x 2
#BRASSPD471/N

D6x1.5 O-Ring x 2
#BRSORD6-15

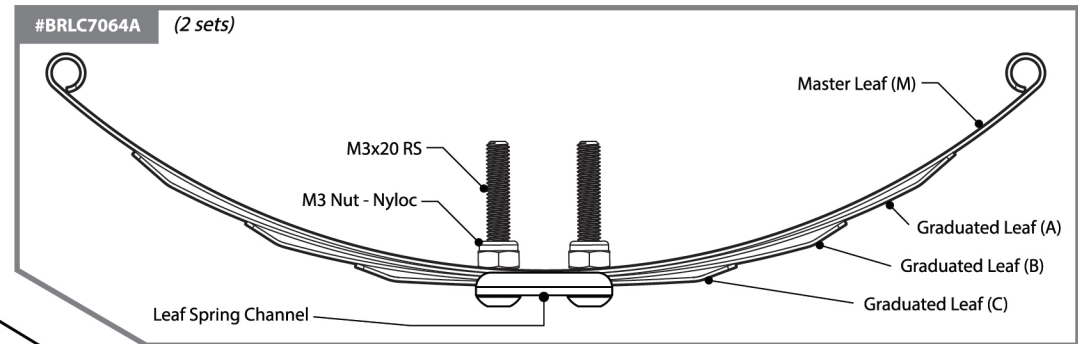

ROD END INSTALLATION

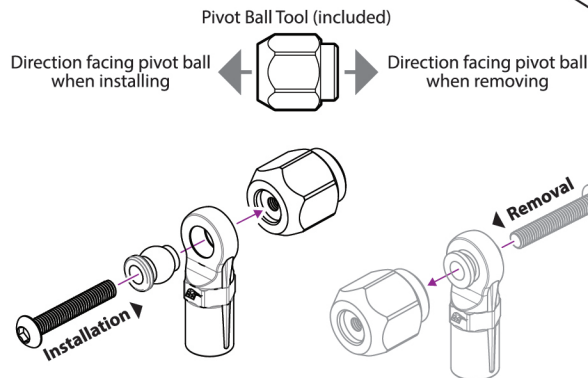

D6x1.5 O-Ring

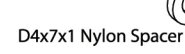

TIE ROD

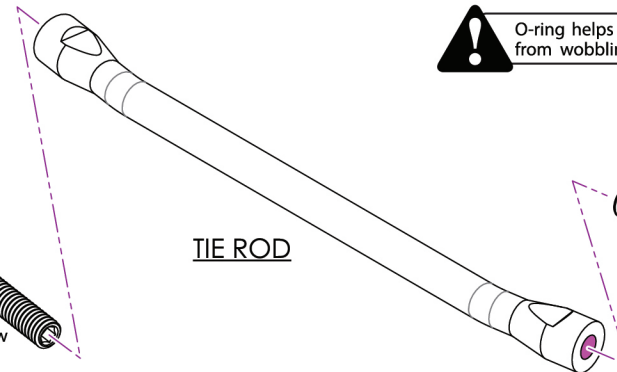

O-ring helps reduce tie rod from wobbling.

D6x1.5 O-Ring

M4x16 Set Screw

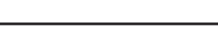

Stainless Steel Pivot Ball

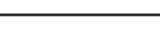
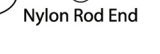

FRONT AXLE & LEAF SPRING

FRONT AXLE & LEAF SPRING

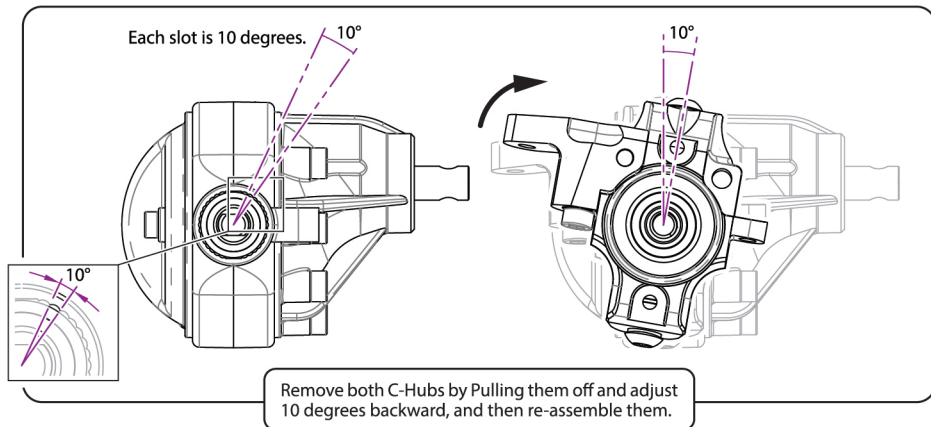

LEAF SPRING LOAD SETUP

Weight	# of Leafs	Lightest	Light	Heavy	Heaviest
Heaviest	4				(M)+(A)+(B)+(C)
Heavy	3		(M)+(B)+(C)	(M)+(A)+(C)	(M)+(A)+(B)
Light	2		(M)+(C)	(M)+(B)	(M)+(A)
Lightest	1	(M)			

Recommended stock setup (Front).

LEAF SPRING CHANNELS

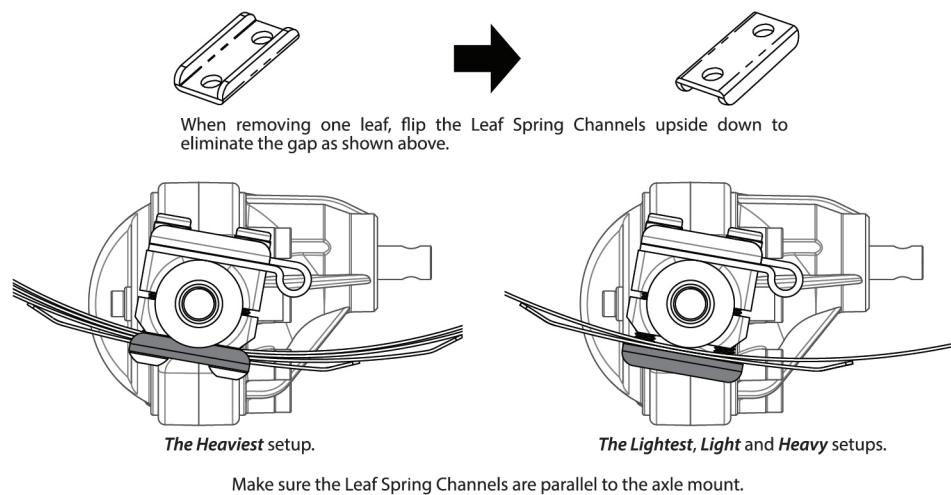

Add thread lock to screws on moving parts.

- B LEAFS / SHOCKS**
- M3x24 RS x 1 #BRASBH3024
 - M3x14 RS x 1 #BRASBH3014
 - 3x6x3 Tapper Spacer x 2 #BRLC7041

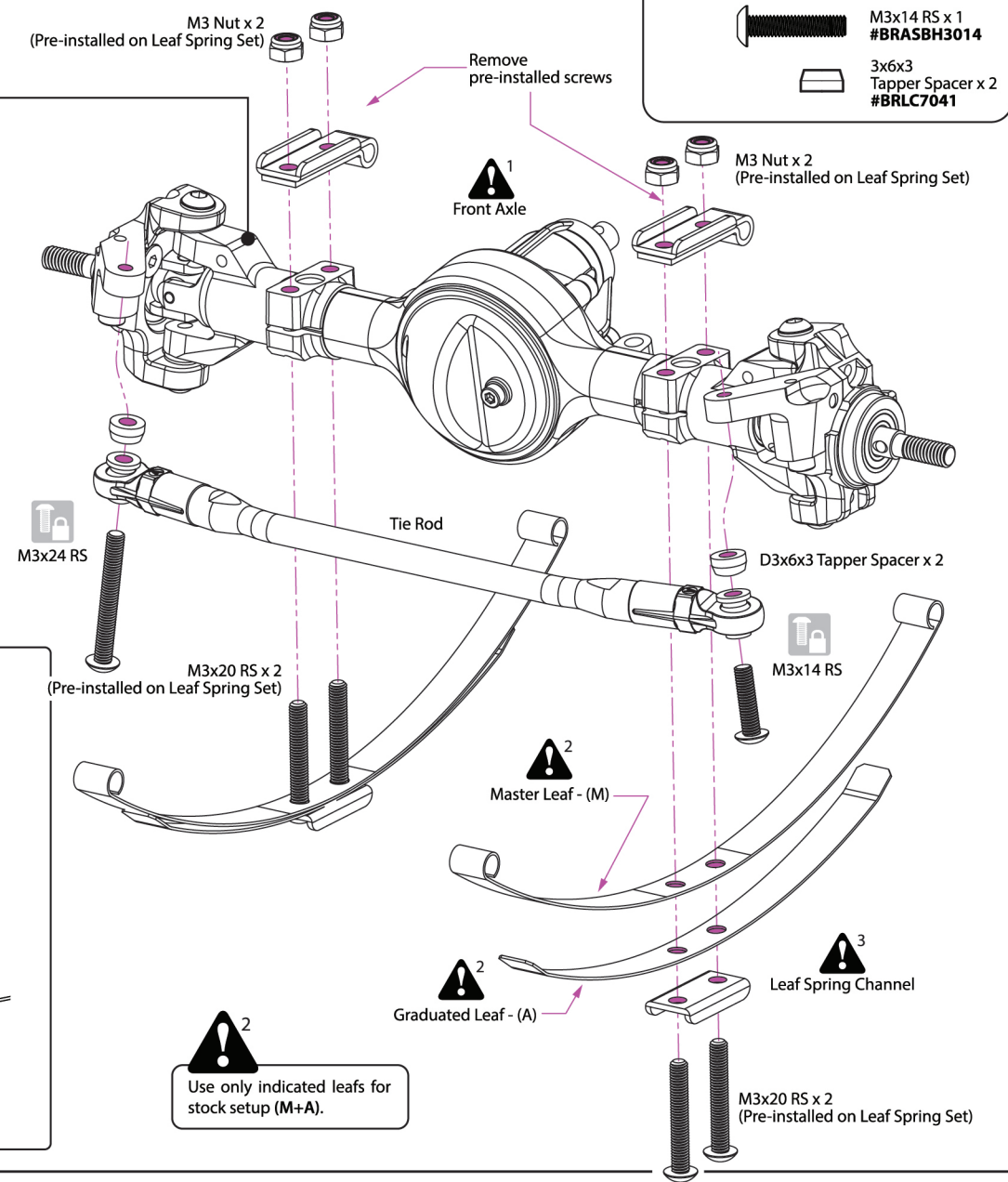

8 - REAR AXLE & LEAF SPRING

Parts Needed:

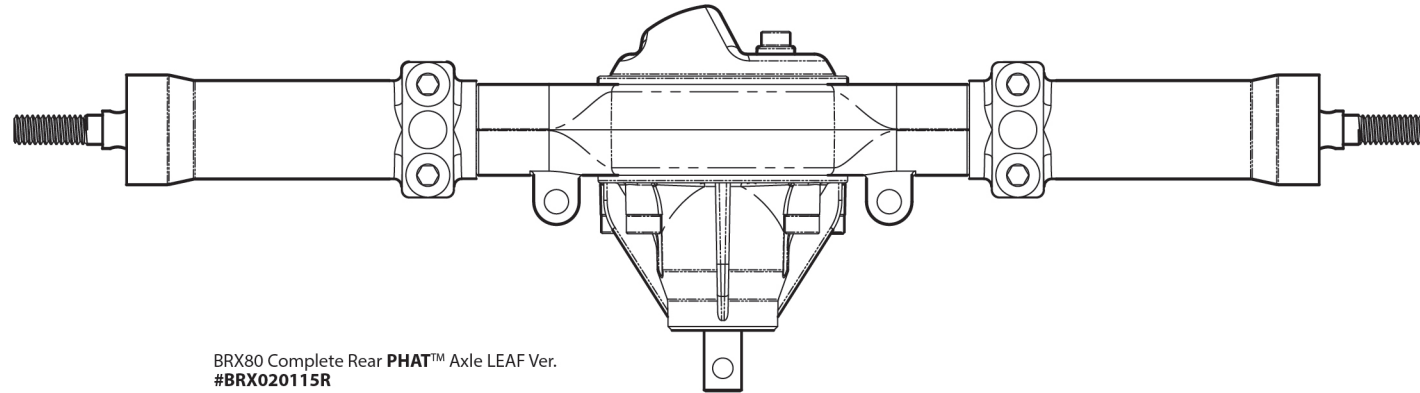

BRX80 Complete Rear PHAT™ Axle LEAF Ver.
 #BRX020115R

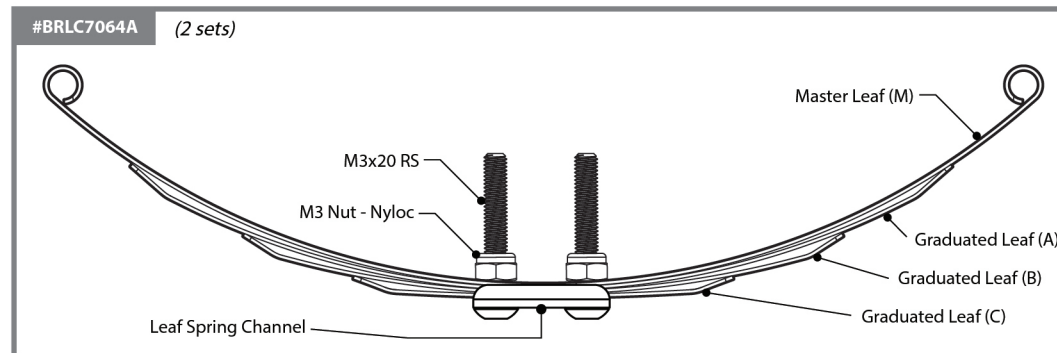

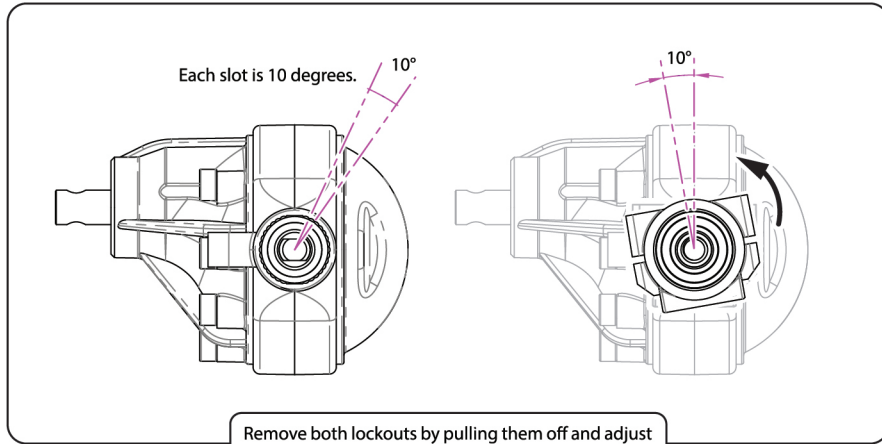

Remove both lockouts by pulling them off and adjust 10 degrees forward, and then re-assemble them.

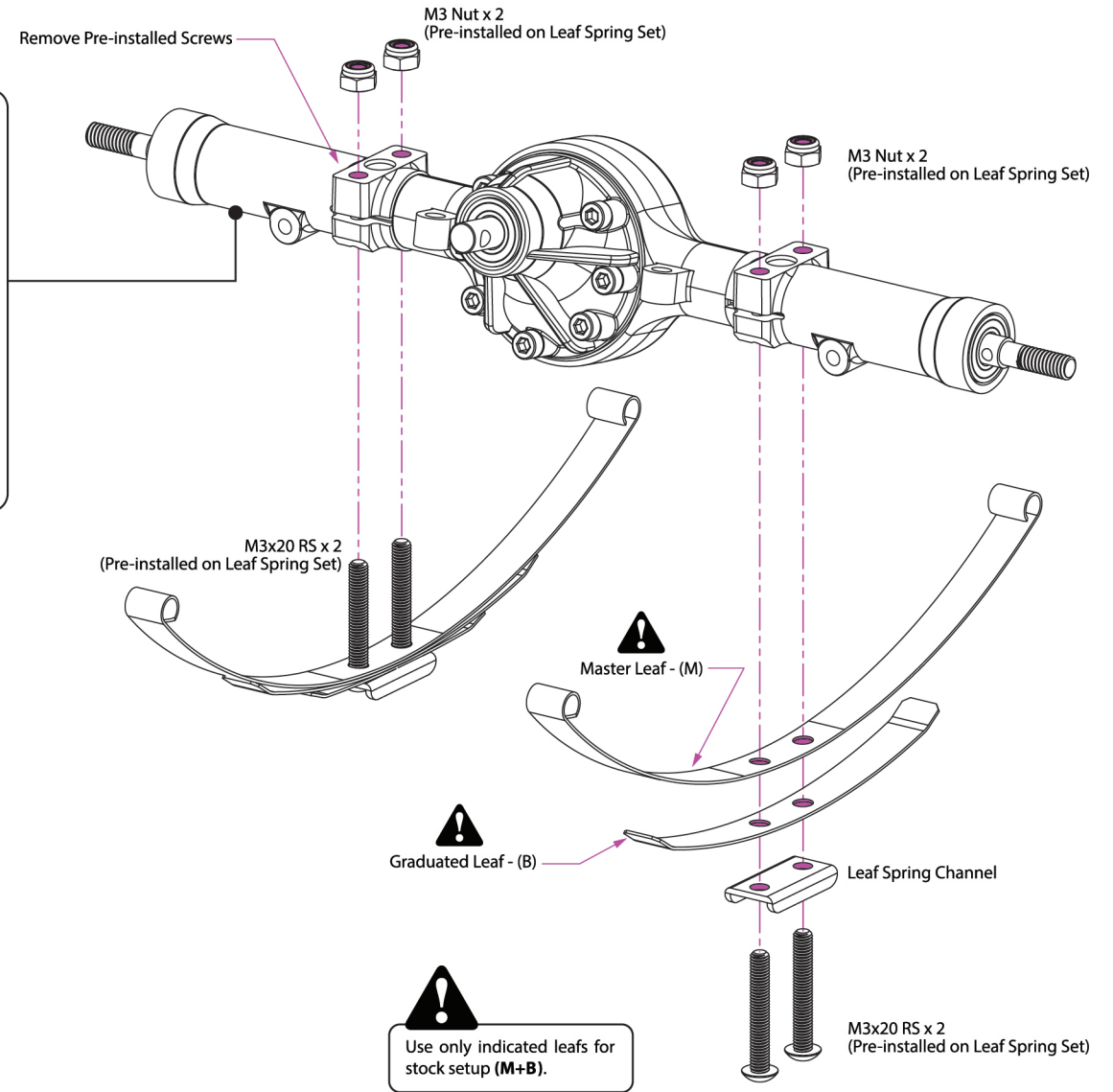

LEAF SPRING LOAD SETUP



Weight	# of Leafs	Lightest	Light	Heavy	Heaviest
Heaviest	4				(M)+(A)+(B)+(C)
Heavy	3		(M)+(B)+(C)	(M)+(A)+(C)	(M)+(A)+(B)
Light	2		(M)+(C)	(M)+(B)	(M)+(A)
Lightest	1	(M)			

■ Recommended stock setup (Rear).

9 - LEAF SPRING SYSTEM

Parts Needed:

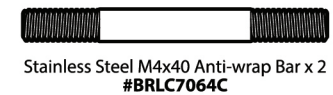
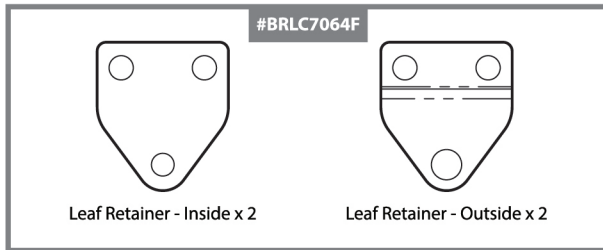
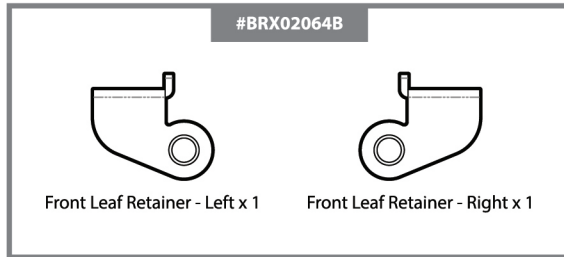

LEAF SPRING SYSTEM



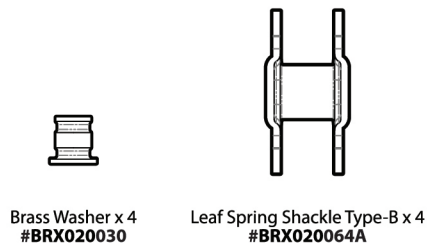

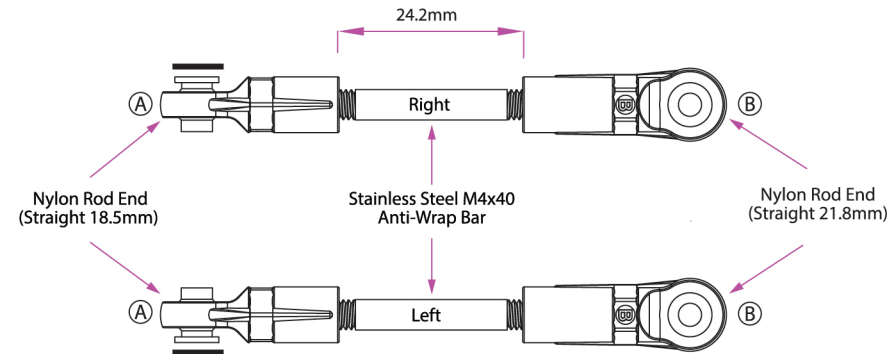

LEAF SPRING SYSTEM



REAR ANTI-WRAP BARS

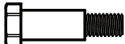

C LEAF SPRINGS

-  M3x22 RS x 2
#BRASBH3022
-  M3x12 RS x 2
#BRASBH3012
-  M3x8 RS x 2
#BRASBH3008
-  M3x14 Bolt x 4
BRLC7064E
-  M3 Nut - Nylon x 8
#BRASNUTM3
-  3x6x3
Tapper Spacer x 2
#BRLC7041
-  D4x7x1
Nylon Spacer x 4
#BRASSPD471/N

 \varnothing 4mm holes face inwards.

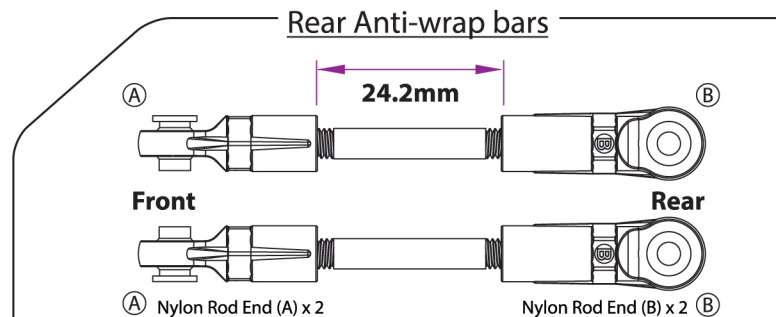
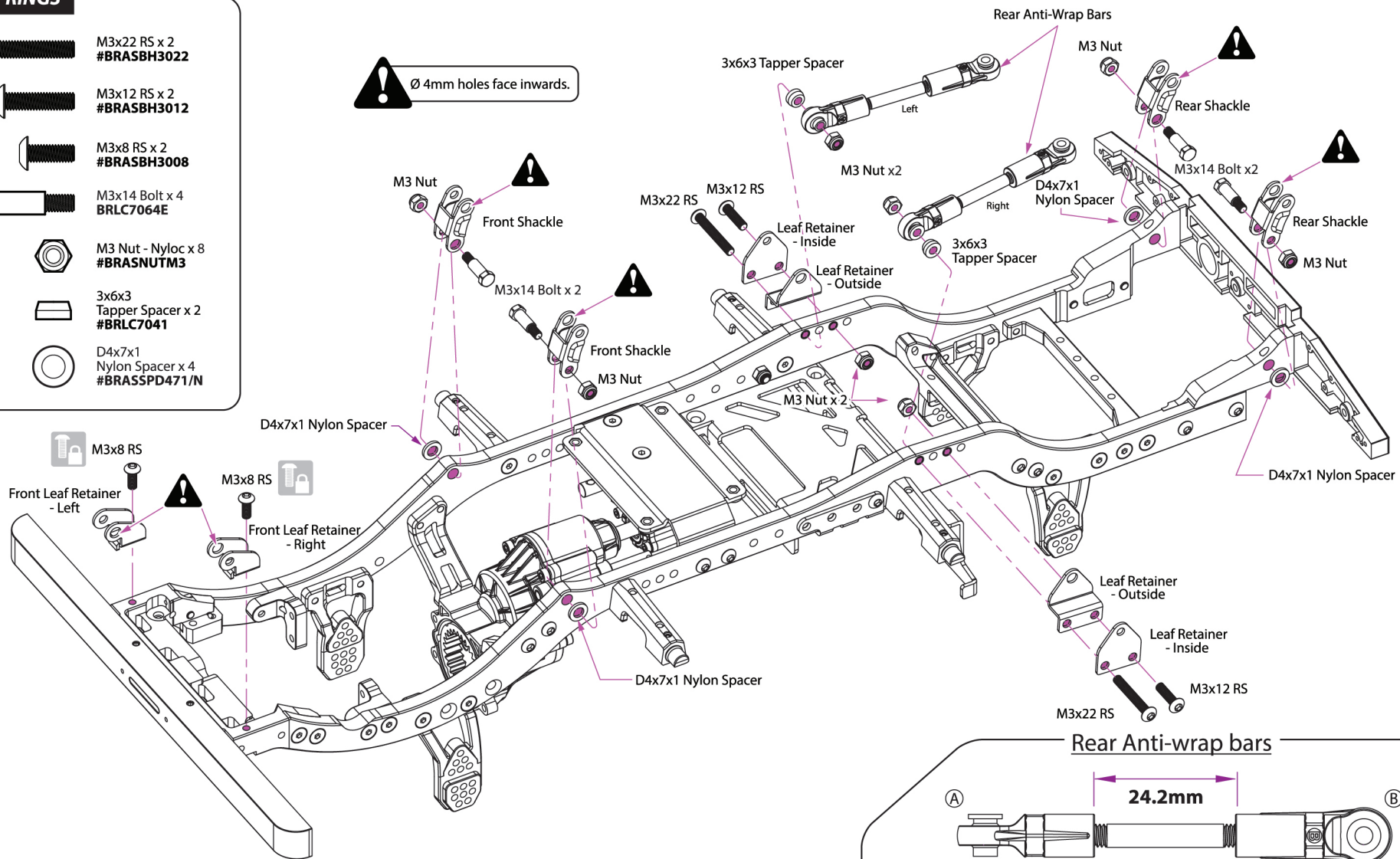

C LEAF SPRINGS

M3x12 RS x 2
 #BRASBH3012



D6x1.5 O-Ring x 8
 #BRSORD6-15

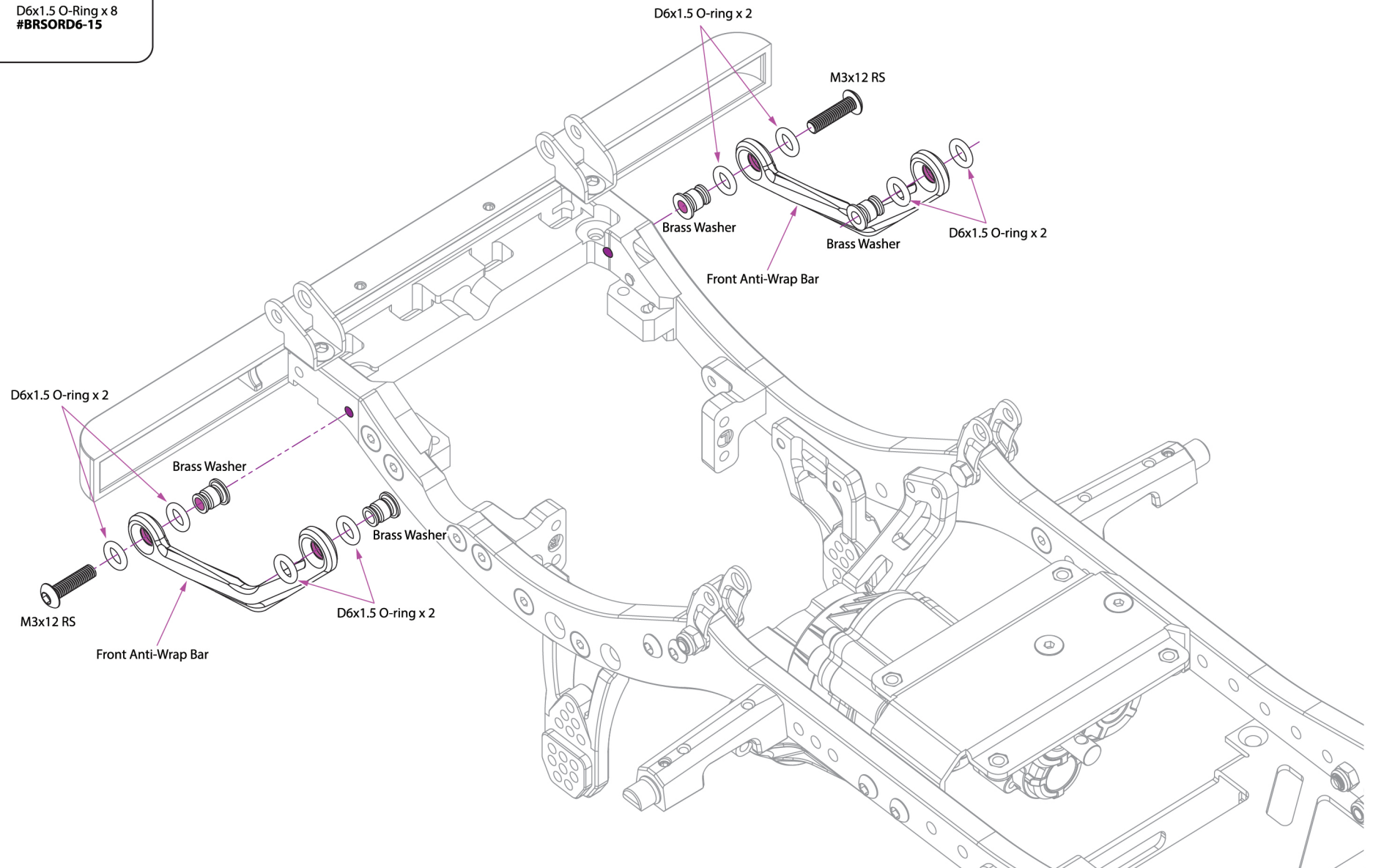

10 - SHOCKS

Parts Needed:

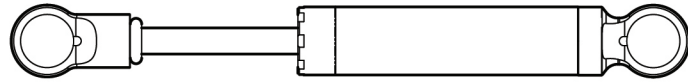

KUDU™ 80mm Scale Shock Absorber x 4
#BRSH0080



Shock End Pivot x 8
#BRW750310



Joint Retainer x 8
#BRSHJR

SHOCKS INSTALLATION & SETUP



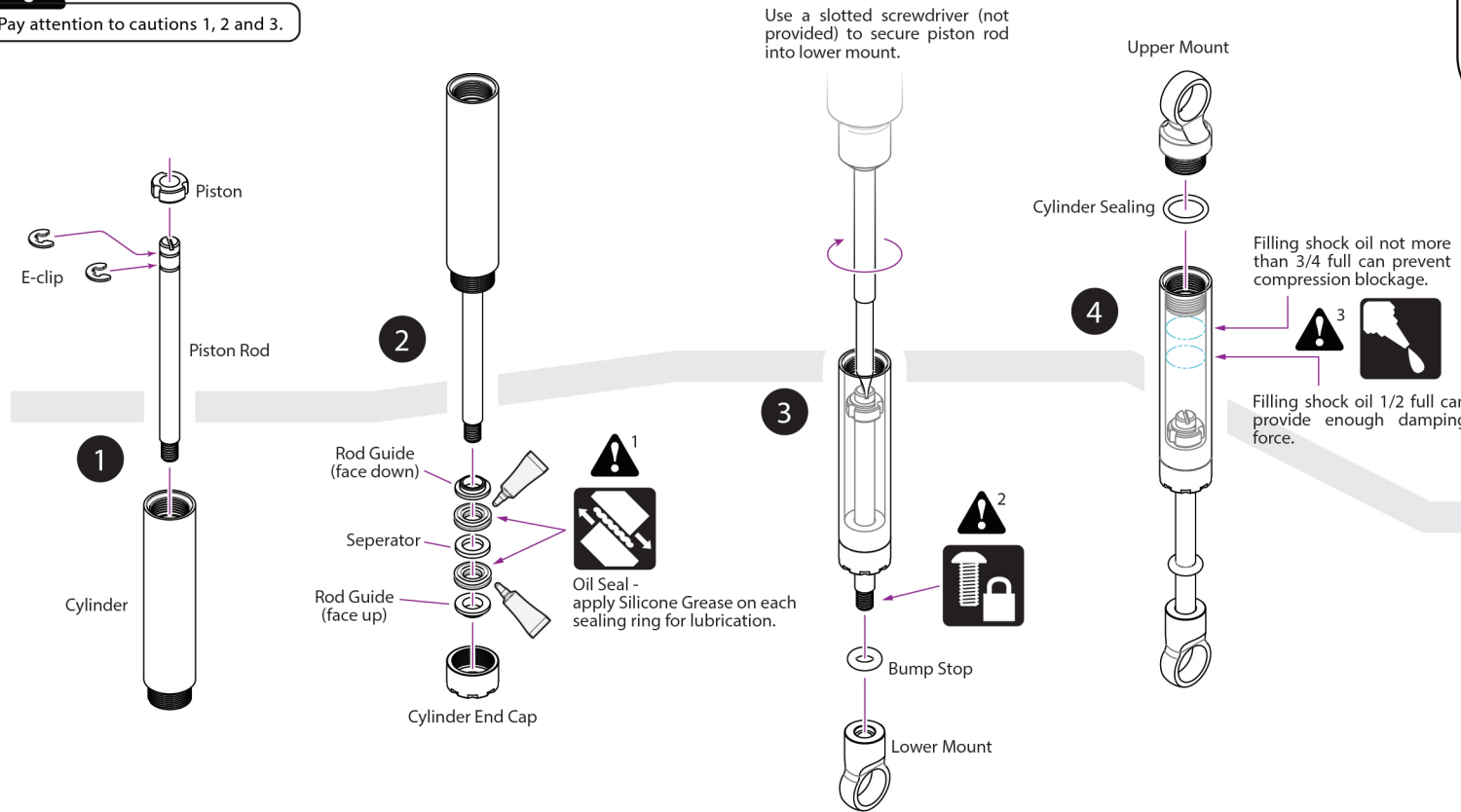

Pay attention to cautions 1, 2 and 3.



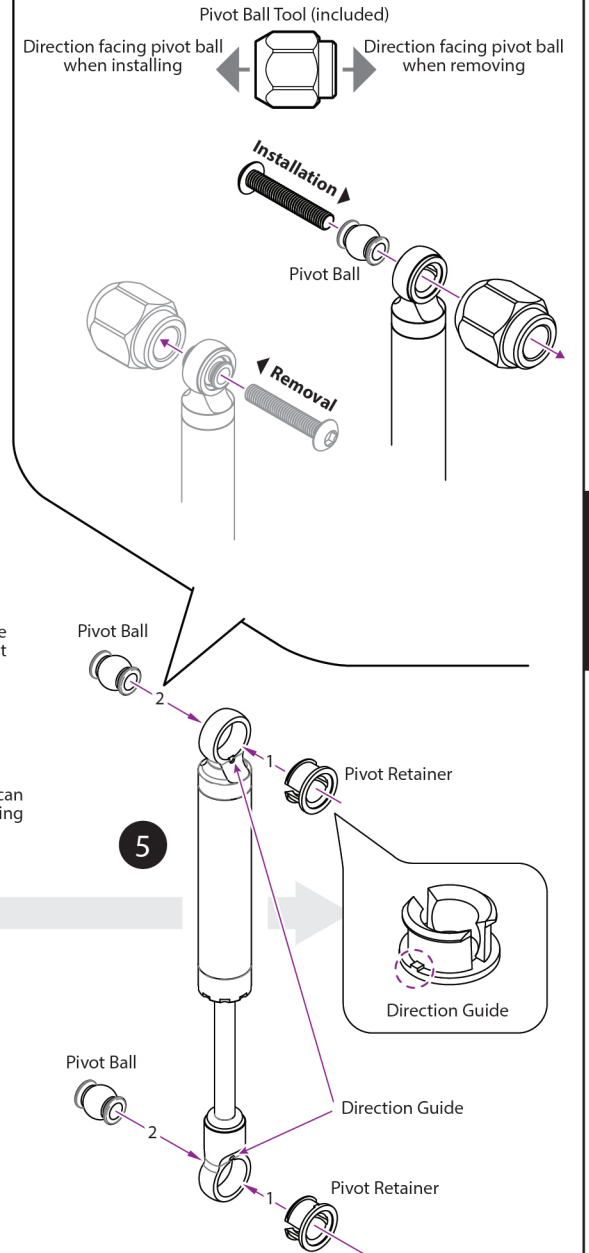

PIVOT BALL INSTALLATION & REMOVAL



B LEAFS / SHOCKS

-  M3x24 RS x 2
#BRASBH3024
-  M3x16 RS x 2
#BRASBH3016
-  3x6x3
Tapper Spacer x 2
#BRLC7041

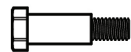

C LEAF SPRINGS

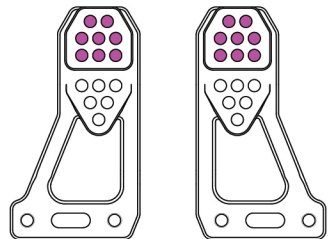
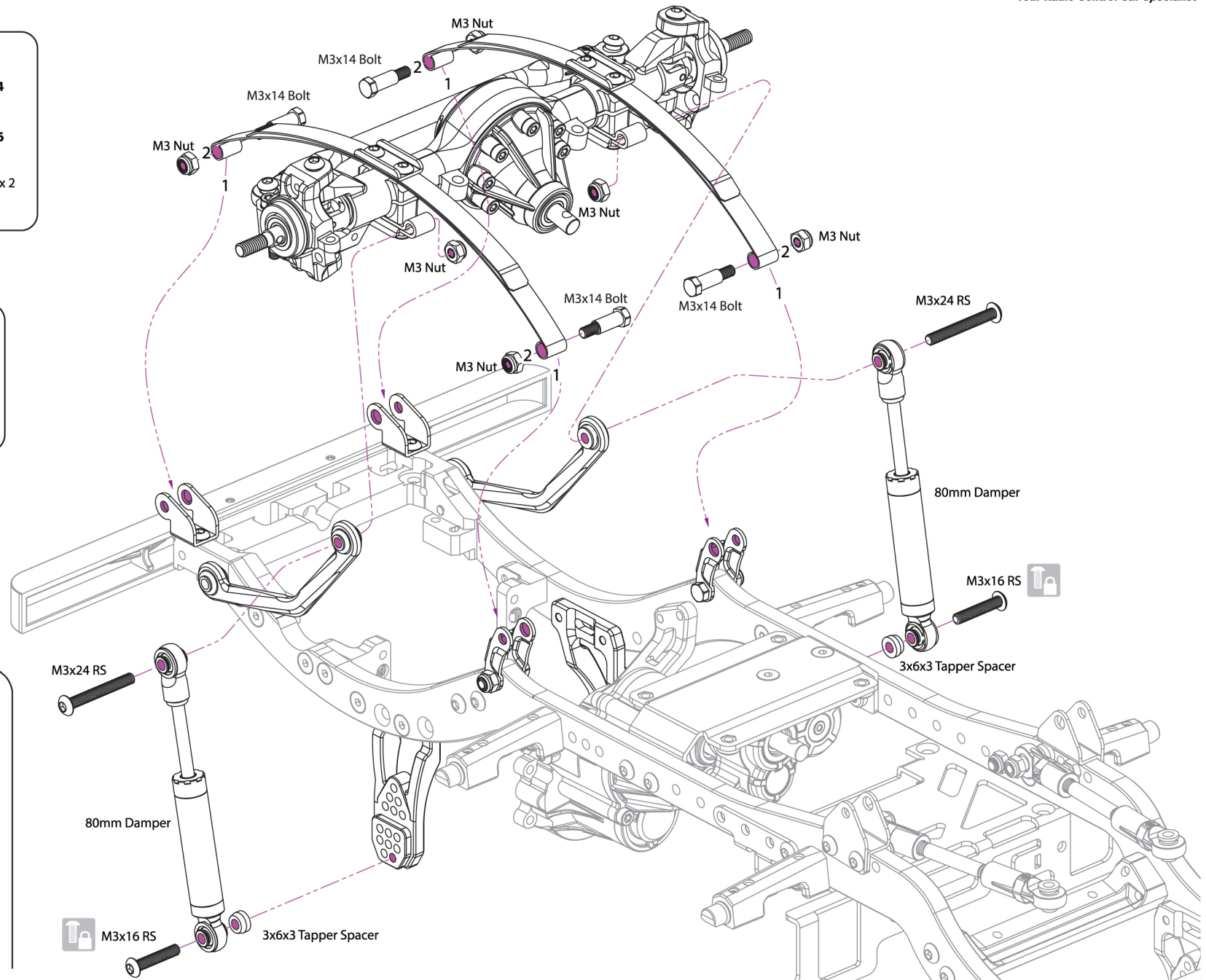
-  M3x14 Bolt x 4
BRLC7064E
-  M3 Nut - Nyloc x 6
#BRASNUTM3





Only use highlighted holes as optional damper installation position to increase chassis ground clearance.

B LEAFS / SHOCKS

-  M3x16 RS x 6
#BRASBH3016
-  3x6x3
Tapper Spacer x 4
#BRLC7041

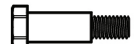
C LEAF SPRINGS

-  M3x14 Bolt x 4
BRLC7064E
-  M3 Nut - Nyloc x 6
#BRASNUTM3

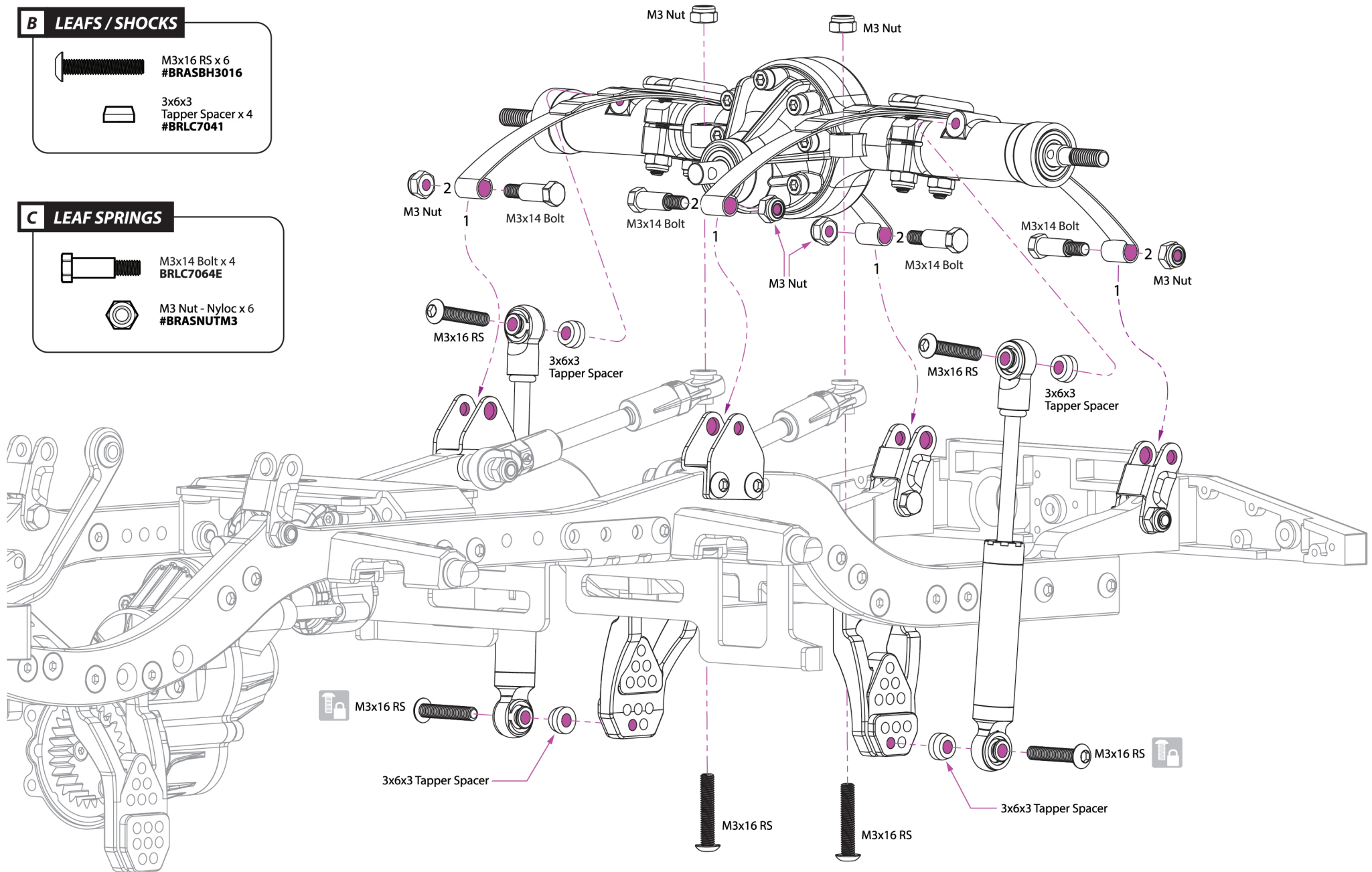

11 - DRIVE SHAFTS

Parts Needed:



KUDU™ HD CVD Rear Center Drive Shaft x 2
#BRX029043

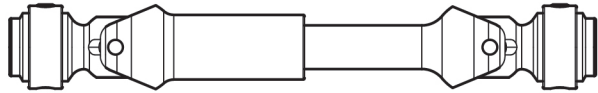

KUDU™ HD CVD Front Center Drive Shaft x 2
#BRX029043

E GEARBOX / TRANSFER CASE

M3/2.2x11 SS x 4
#BRASST3022/DS

! Align input shaft hole and drive shaft hole properly. Use the 1.5 Hex Key provided to help pull out the shaft if needed.

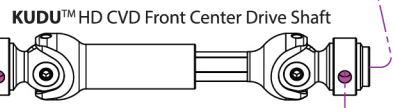
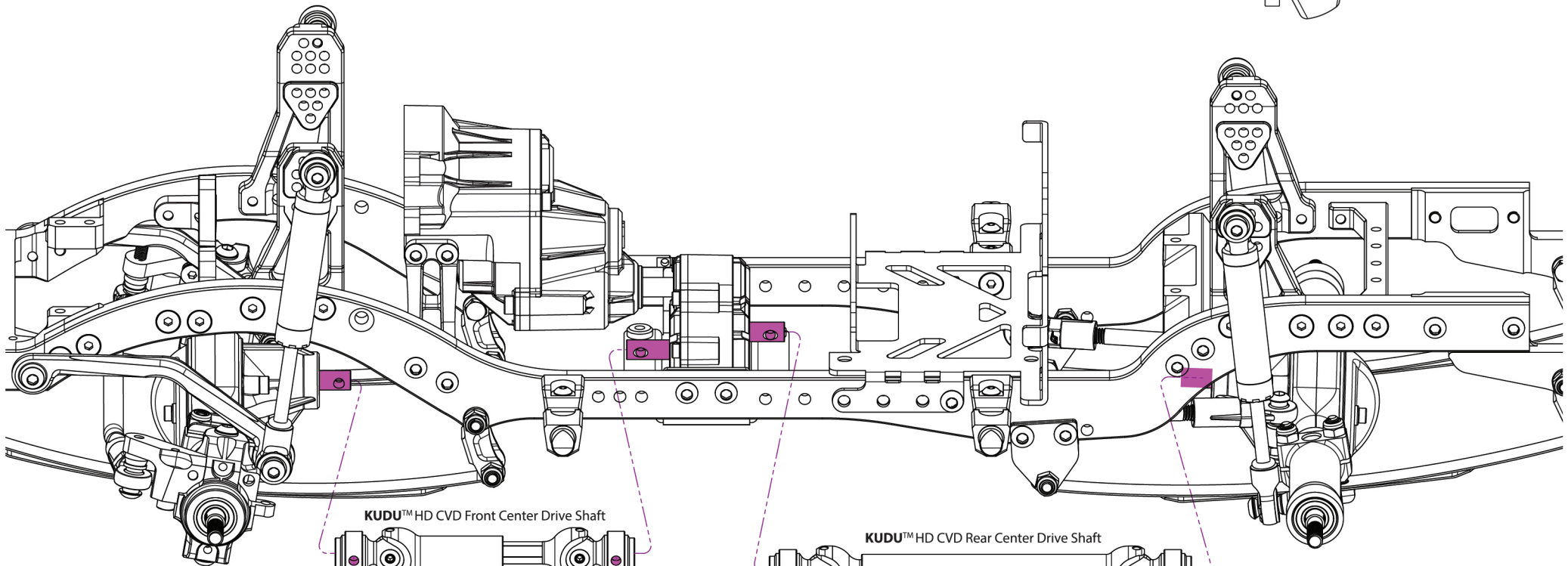

KUDU™ HD CVD Front Center Drive Shaft

M3/2.2x11 Set Screw x 2

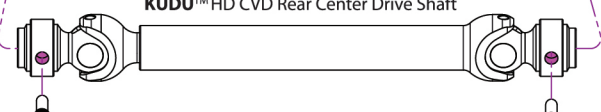

KUDU™ HD CVD Rear Center Drive Shaft

M3/2.2x11 Set Screw x 2

DRIVE SHAFTS

DRIVE SHAFTS

12 - SERVOS & SKID SLIDER

Parts Needed:

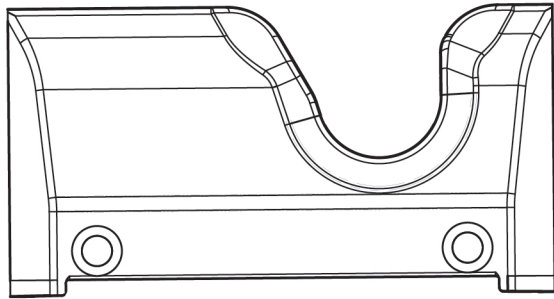

Front Center Skid Slider x 1
#BRX020107F

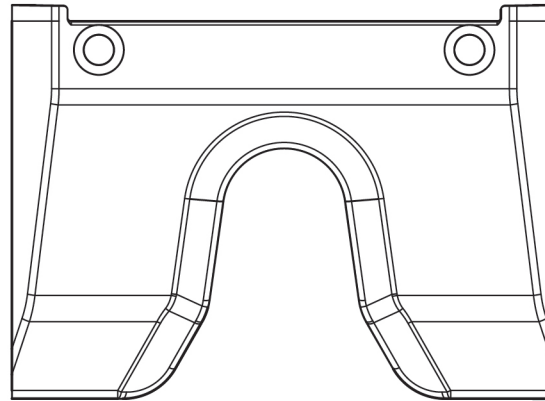

Rear Center Skid Slider x 1
#BRX020107R

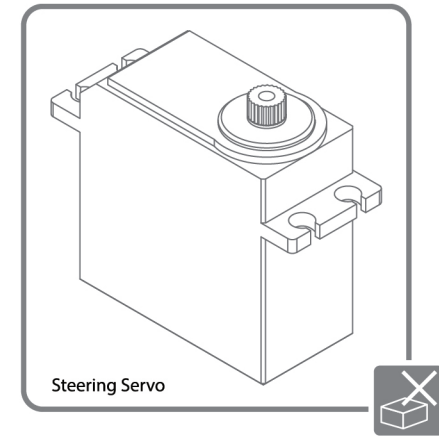

Steering Servo

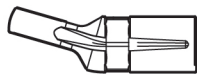

Nylon Rod End (Upwards 20.0mm) x 1
#BRW750307D

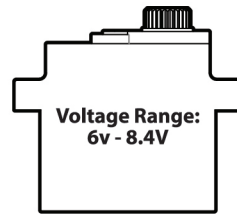

JX Waterproof HV Mini Servo x 1
#JX/PDI-HV1151MG

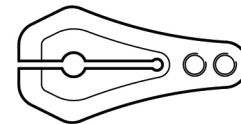

Servo Horn A - 25T x 1
#BR955014BK



Nylon Rod End
19.5mm (Sideways) x 1
#BRW750308C





BADASS™
Stainless Steel Pivot Ball x 2
#BRW750300





Fine Tunable Link - 55mm x 1
#BRLC7050

47 **H** **SERVOS**

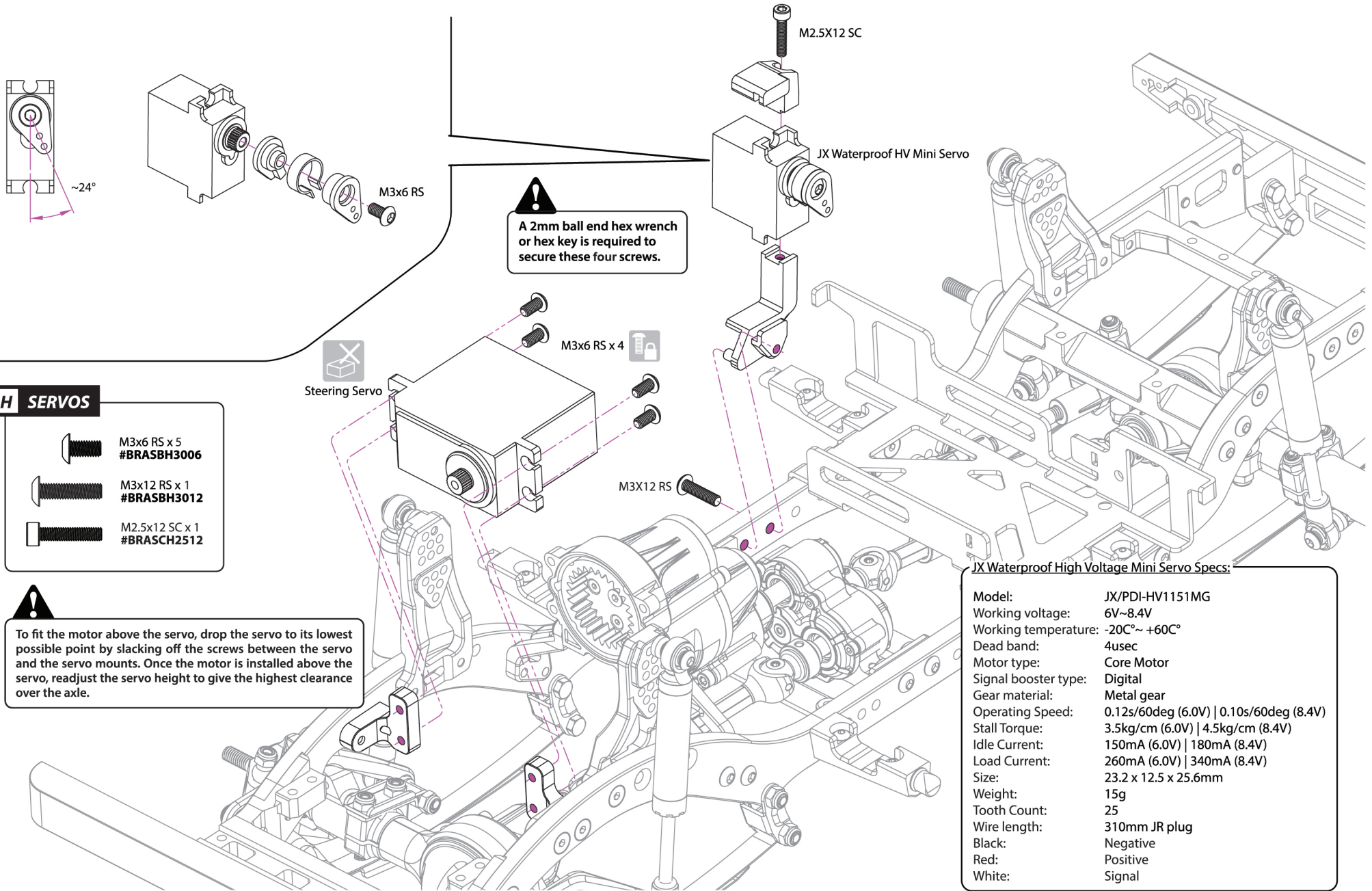
		
Follower Horn A	Initiator Horn A	Spring Horn A
#BRLC7049		



- H SERVOS**
-  M3x6 RS x 5
#BRASBH3006
 -  M3x12 RS x 1
#BRASBH3012
 -  M2.5x12 SC x 1
#BRASCH2512



!
To fit the motor above the servo, drop the servo to its lowest possible point by slacking off the screws between the servo and the servo mounts. Once the motor is installed above the servo, readjust the servo height to give the highest clearance over the axle.

!
A 2mm ball end hex wrench or hex key is required to secure these four screws.

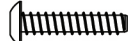

JX Waterproof High Voltage Mini Servo Specs:

Model:	JX/PDI-HV1151MG
Working voltage:	6V~8.4V
Working temperature:	-20C°~ +60C°
Dead band:	4usec
Motor type:	Core Motor
Signal booster type:	Digital
Gear material:	Metal gear
Operating Speed:	0.12s/60deg (6.0V) 0.10s/60deg (8.4V)
Stall Torque:	3.5kg/cm (6.0V) 4.5kg/cm (8.4V)
Idle Current:	150mA (6.0V) 180mA (8.4V)
Load Current:	260mA (6.0V) 340mA (8.4V)
Size:	23.2 x 12.5 x 25.6mm
Weight:	15g
Tooth Count:	25
Wire length:	310mm JR plug
Black:	Negative
Red:	Positive
White:	Signal



A CHASSIS

-  M3x14 RS x 4
#BRASBH3014/ST
-  M3x6 RS x 4
#BRASCH3006

B LEAFS / SHOCKS

-  M3x10 RS x 1
#BRASBH3010
-  M3 Nut - Nyloc x 1
#BRASNUTM3

H SERVOS

-  M3x6 RS x 1
#BRASBH3006
-  M2x8 SC x 2
#BRASCH2008

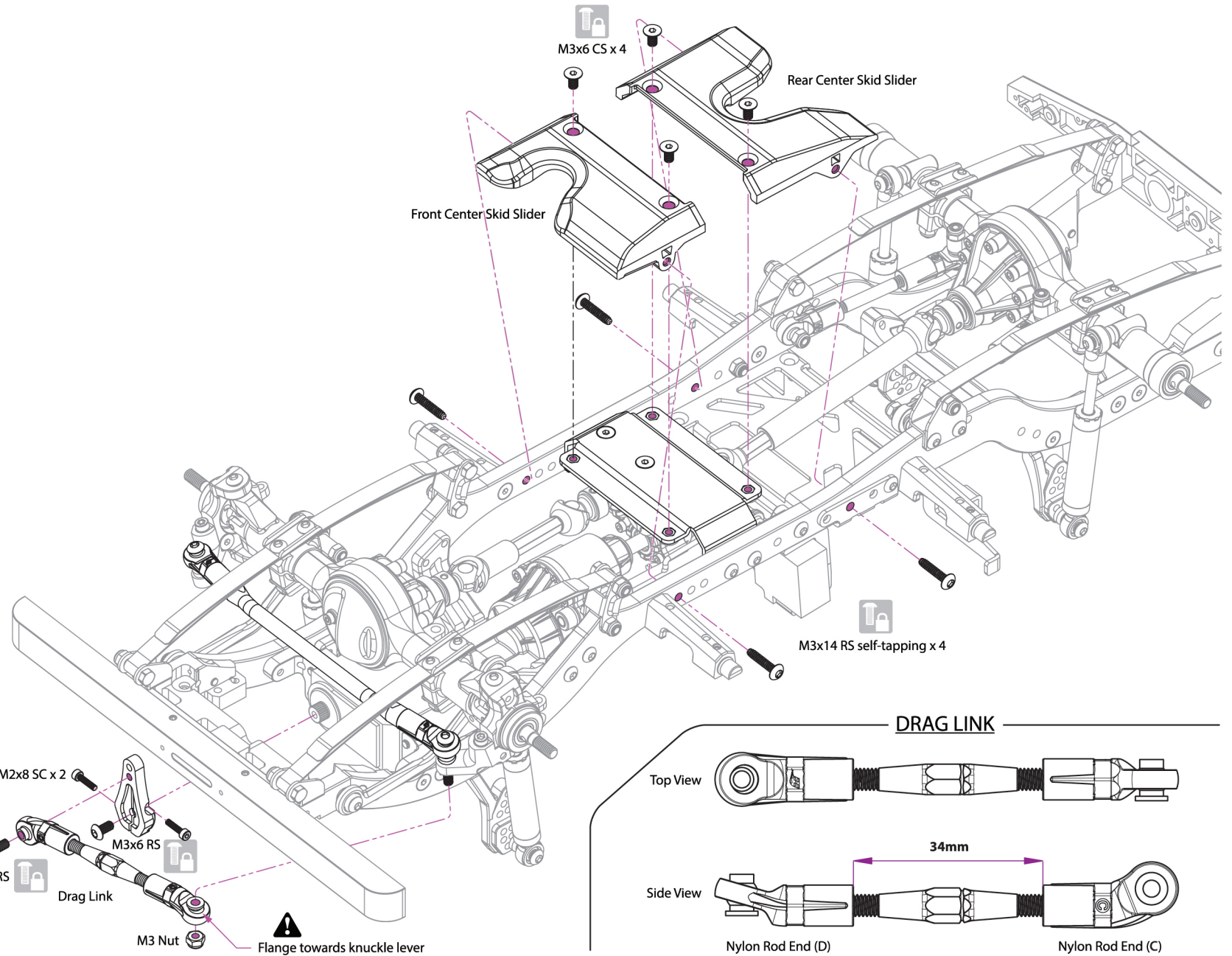

DRAG LINK

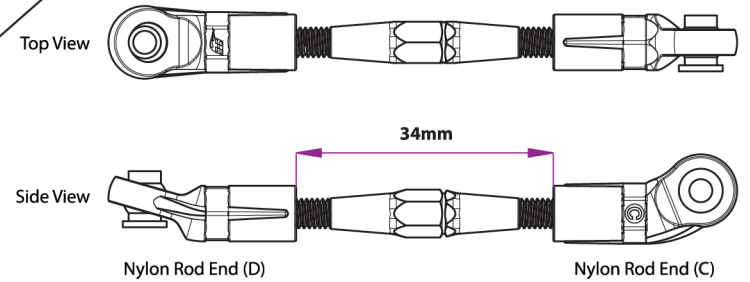

13 - SHIFT ROD

Parts Needed:

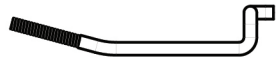

Shift Rod x 1
#BRX029051



D2 Ball & Rod End x 1
#BRQ90351



H SERVOS



M2x8 SC x 1
#BRASCH2008

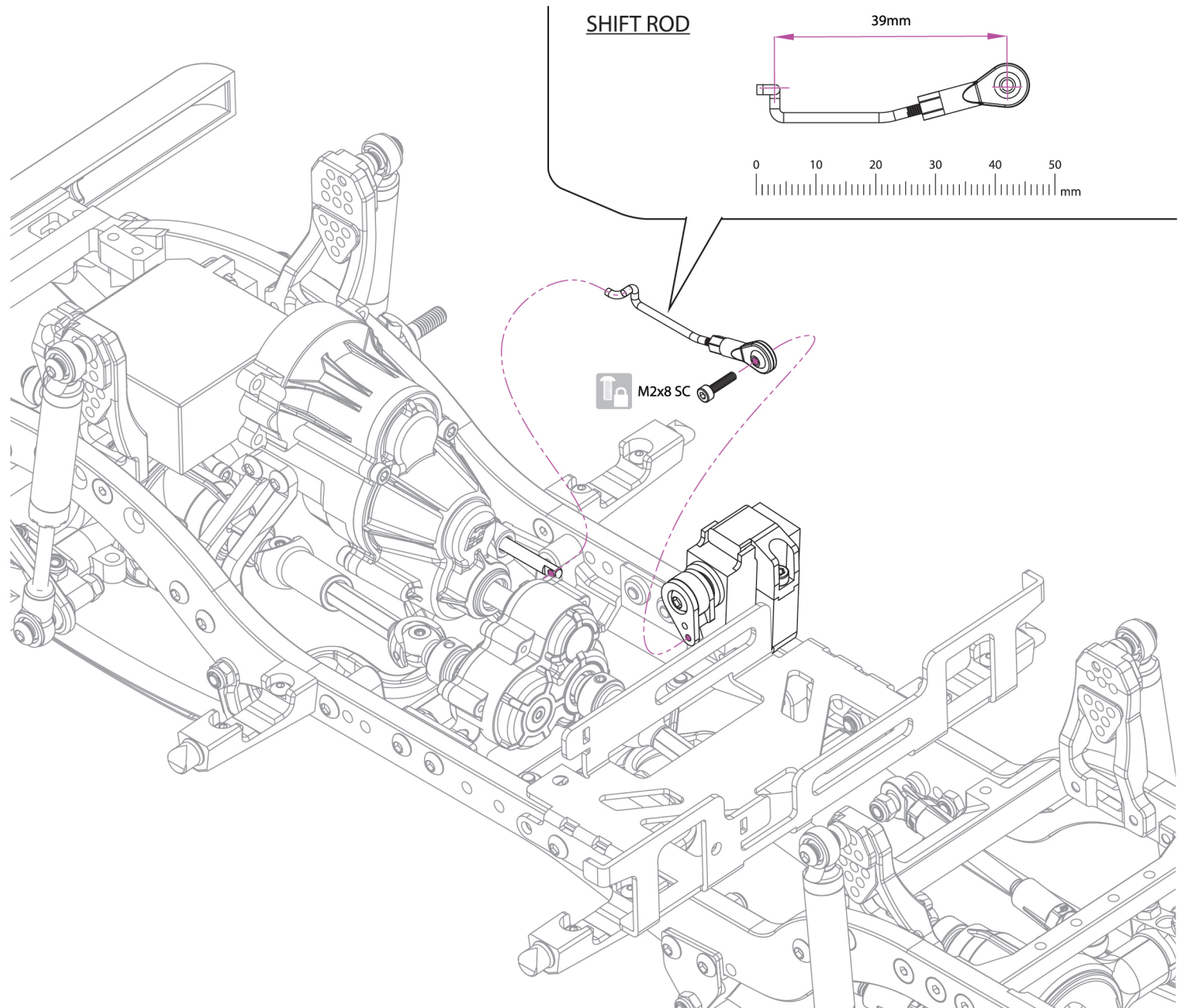

14 - MOTOR

Parts Needed:

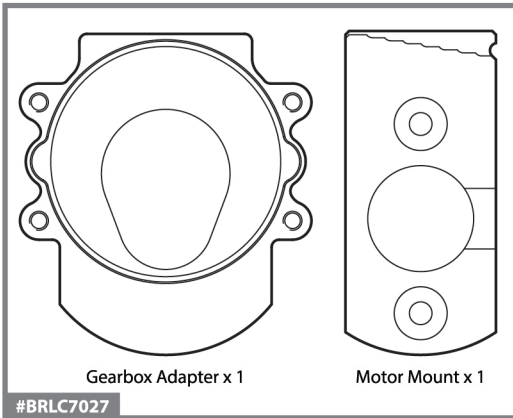
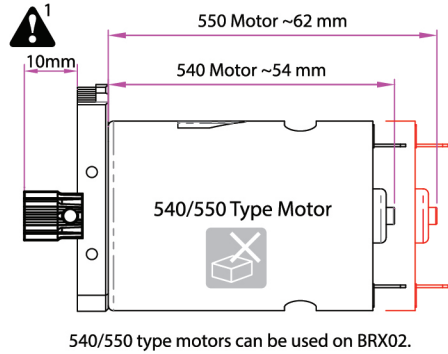

GEARBOX / TRANSFER CASE

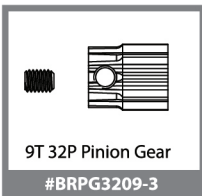
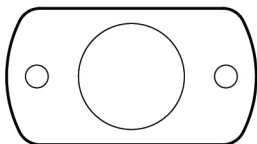

2
Use the corresponding number of the pinion gear tooth (**1**) on the Motor Mount to get the best gear mesh. Adjust the Motor Mount up and down until both surface indicators (**2**) are leveled (align at index 9T for the 9T pinion gear supplied as pictured).

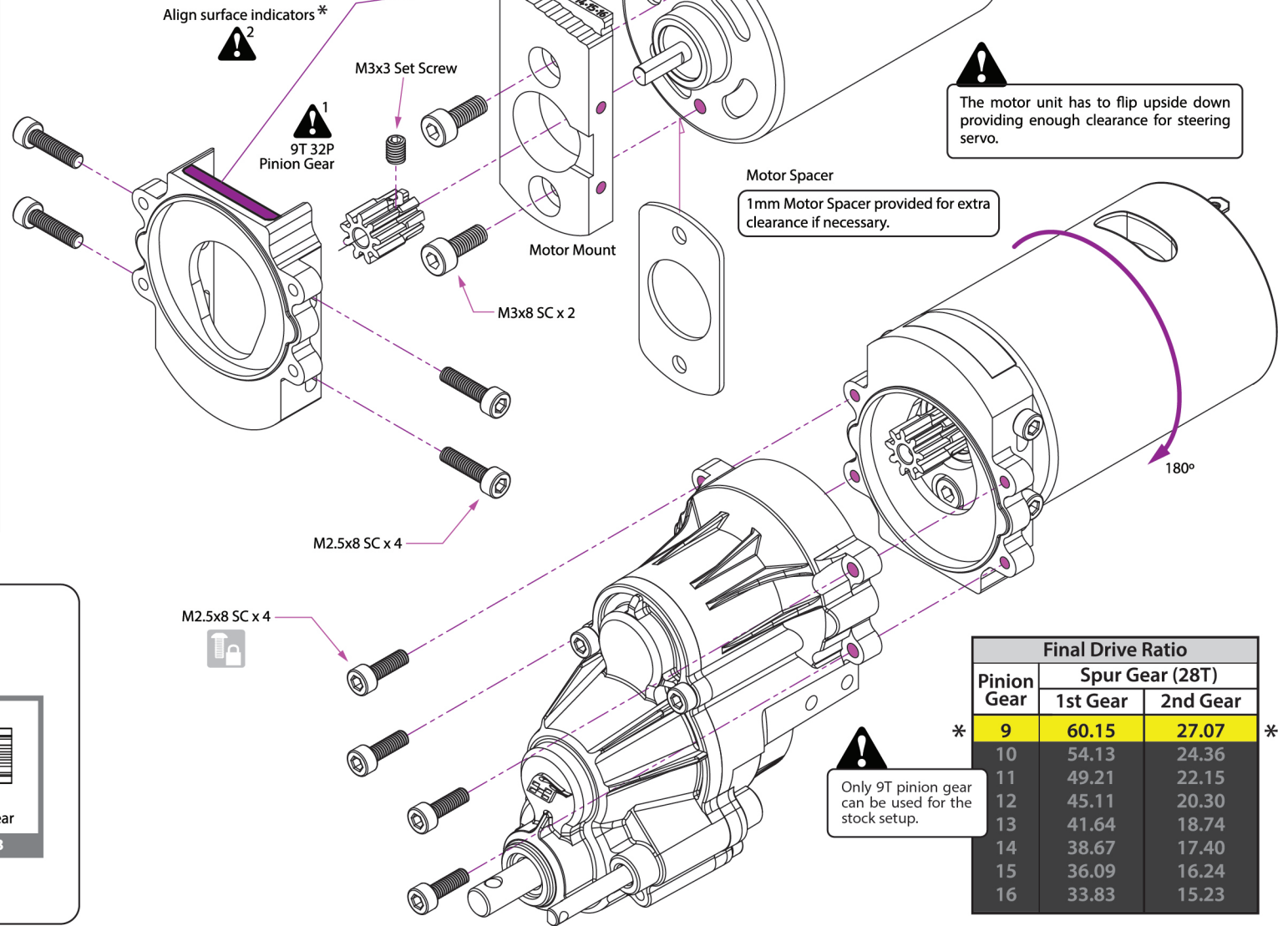

!
The motor unit has to flip upside down providing enough clearance for steering servo.

!
Only 9T pinion gear can be used for the stock setup.

Pinion Gear	Final Drive Ratio	
	Spur Gear (28T)	
	1st Gear	2nd Gear
* 9	60.15	27.07 *
10	54.13	24.36
11	49.21	22.15
12	45.11	20.30
13	41.64	18.74
14	38.67	17.40
15	36.09	16.24
16	33.83	15.23

15 - RECEIVER BOX & ELECTRONICS INSTALLATION

Parts Needed:

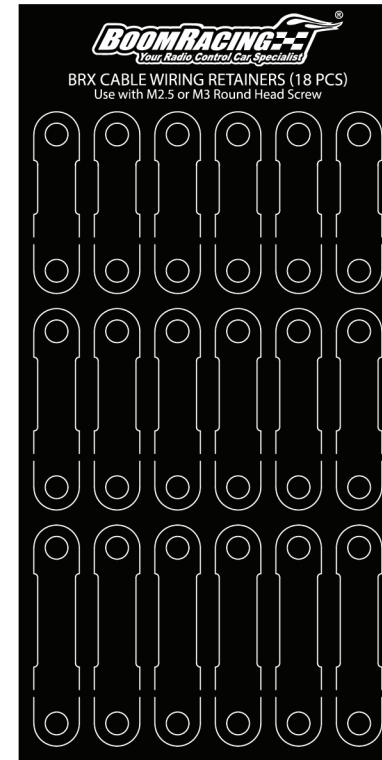
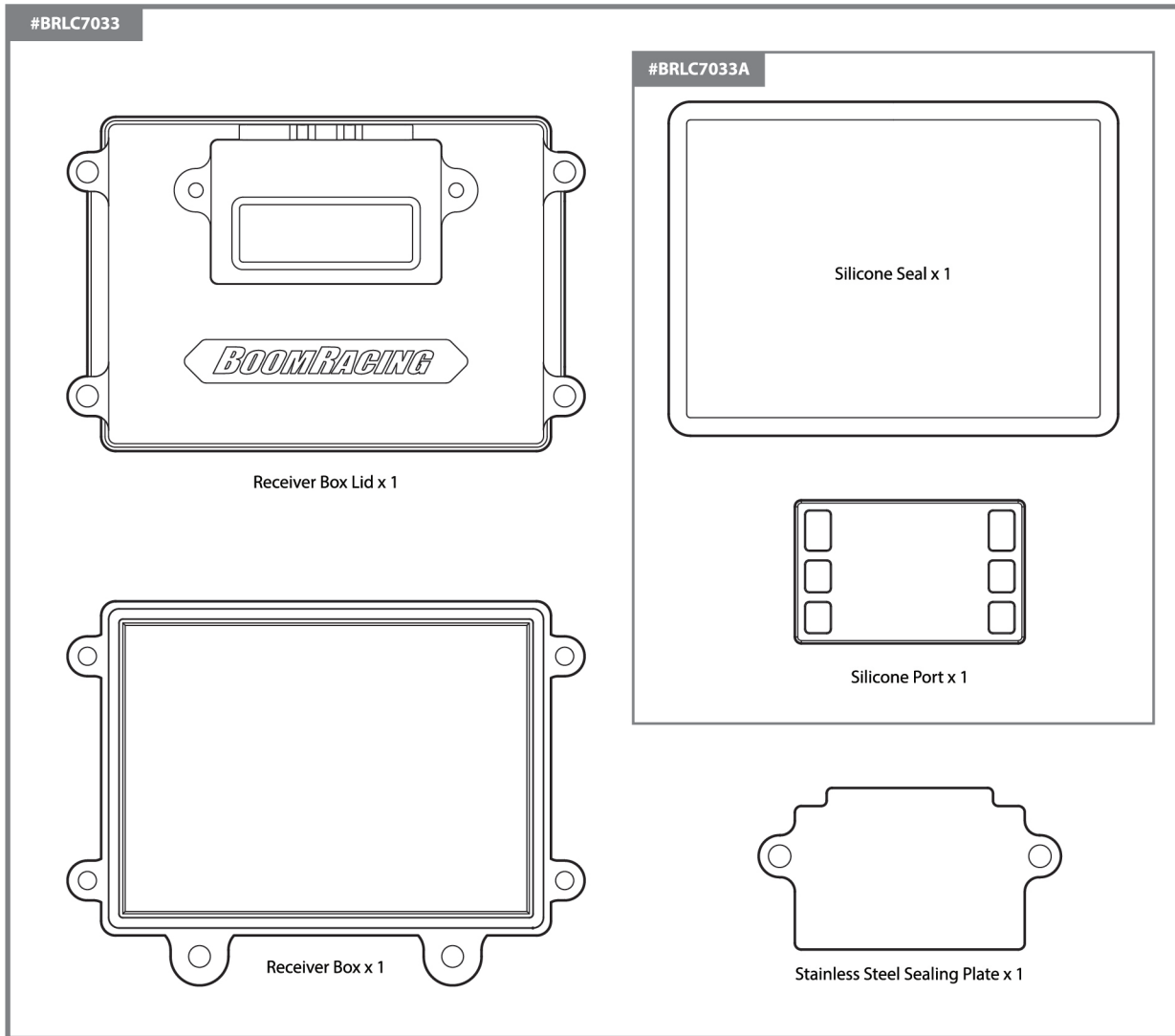

Cable Wiring Retainers
#BRT10037

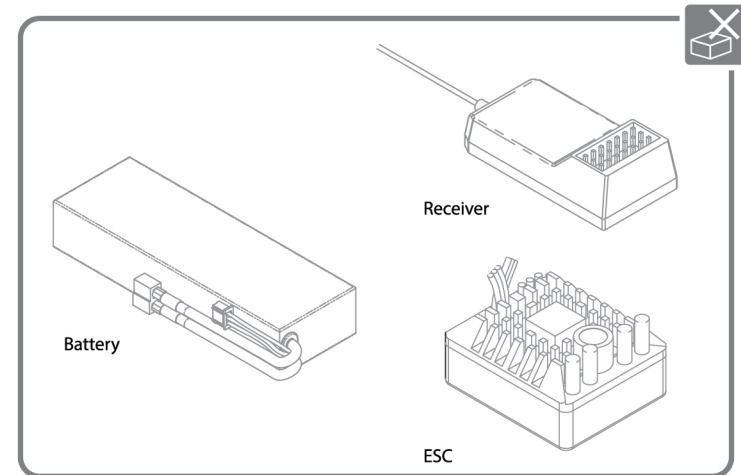

A CHASSIS

M3x6 RS x 2
#BRASBH3006

F RECEIVER BOX

M3x22 RS x 2
#BRASBH3022

Battery (not provided)



Battery

ESC Mounting Plate



ESC (not provided)
Max. clearance between
mounting plate and motor: 22mm



M3x6RS x 2



ESC

9mm Spacer x2

CABLE WIRING RETAINER

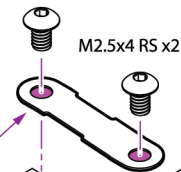

Use the shortest cable wiring
retainer provided to secure
cables.

The recessed shape on
body post is designed for
cable routing.

A CHASSIS

M2.5x4 RS x 8
#BRASBH2504

Receiver Box

M3x22 RS x 2

F RECEIVER BOX

M3x8 RS x 4
#BRASBH3008

M2.5x6 RS x 2
#BRASBH2506

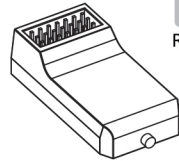

Receiver

Receiver (not provided)
The orientation depends on
the model used.

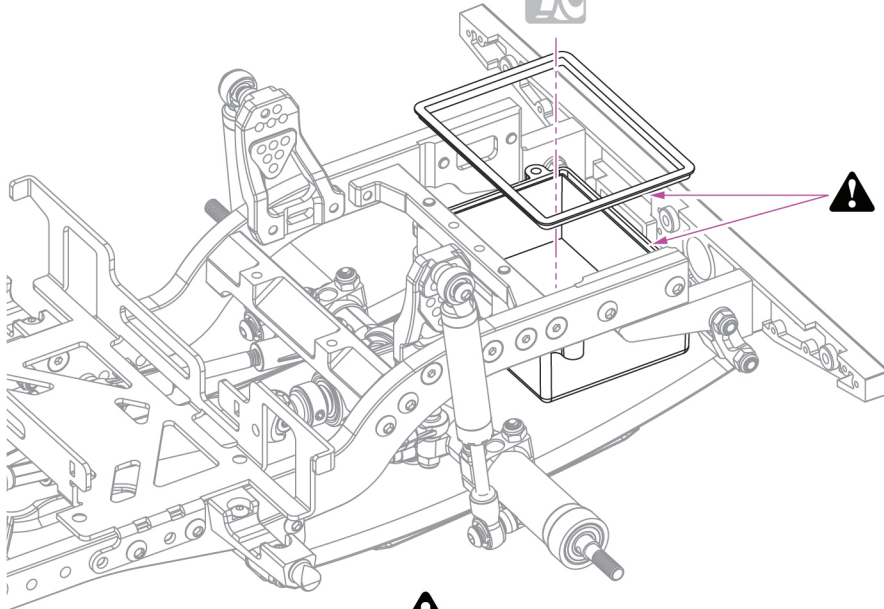

!
To fully waterproof the receiver box, apply a generous amount of Silicone Grease into and around the two silicone sealings to create an airtight seal.

The BRX02 is designed to go anywhere. This includes being fully submerged under water. To protect electronics from water damage, all electronics must be fully waterproofed. It is your responsibility to fully waterproof all electronics before driving in wet conditions.

!
Apply Silicone Grease around and into the silicone sealing to create an airtight seal.

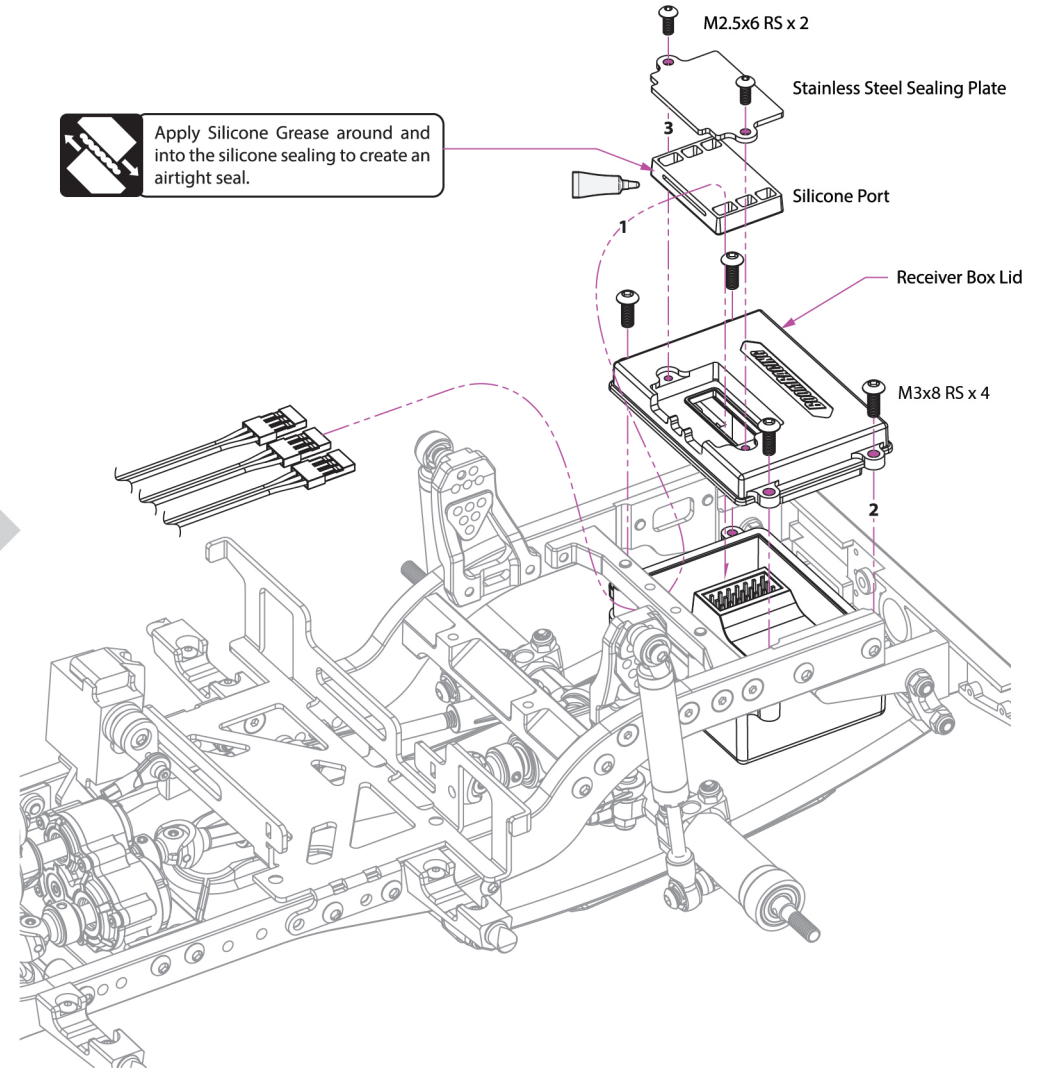

16 - WHEELS & TIRES

Parts Needed:

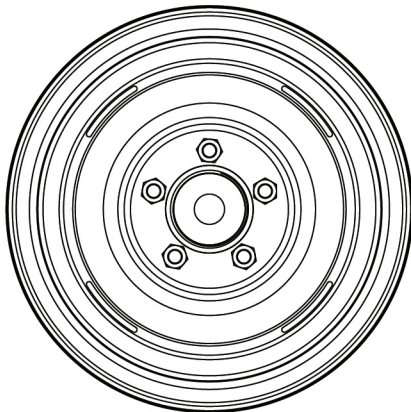
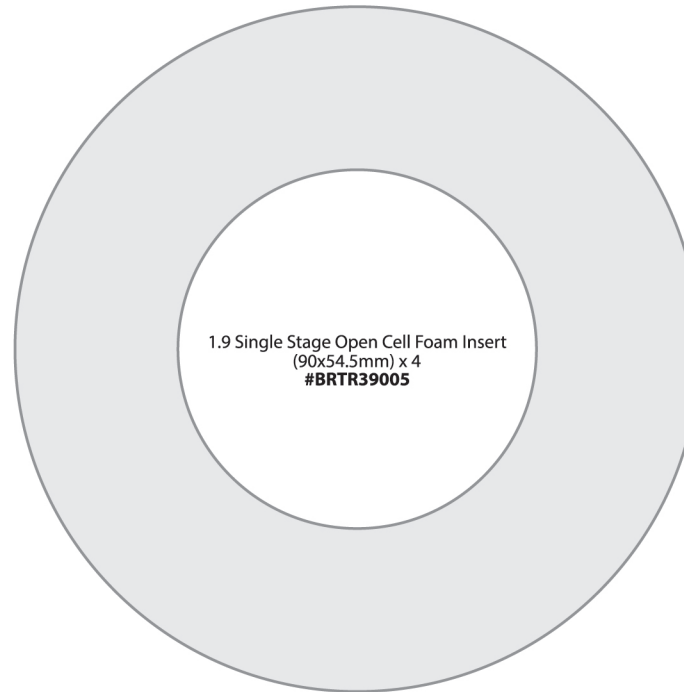
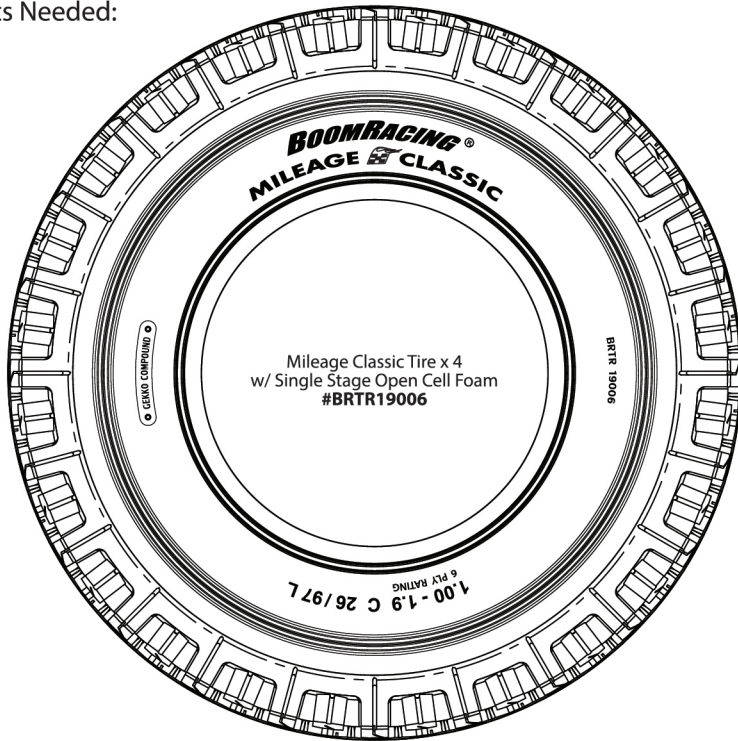

SLR™ 1.9 Classic Steel Wheel x 4
w/ Cap and Scale Hardware
#BRW780944
with (#XT502PIN) Wheel Hub



Nylon Wheel Hub Caps x 4
#BRW780944C

C LEAF SPRINGS

 M2.5x14 RS x 2
#BRASBH2514

 2.5 Nut x 2
#BRASNUTM25

D WHEELS

 M4 Nut - Nyloc x 4
#BRASNUTM4

 2x10mm Pin x 4
#BRASPIN210

 D4x7x2
Aluminum Spacer x 4
#BRASSP472

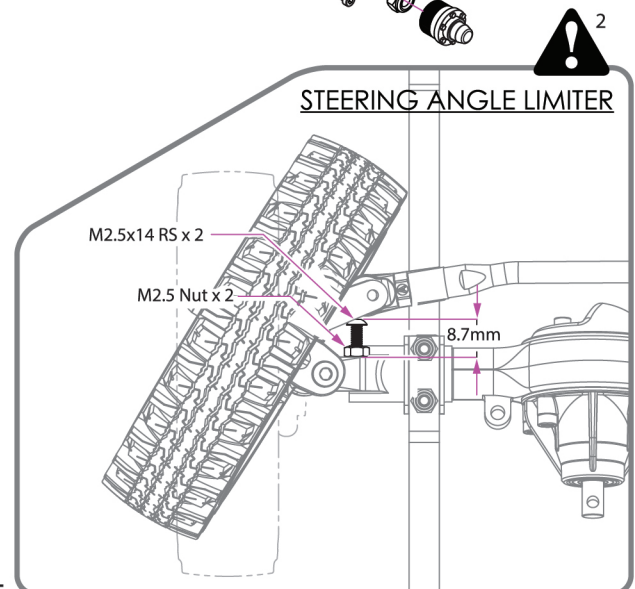
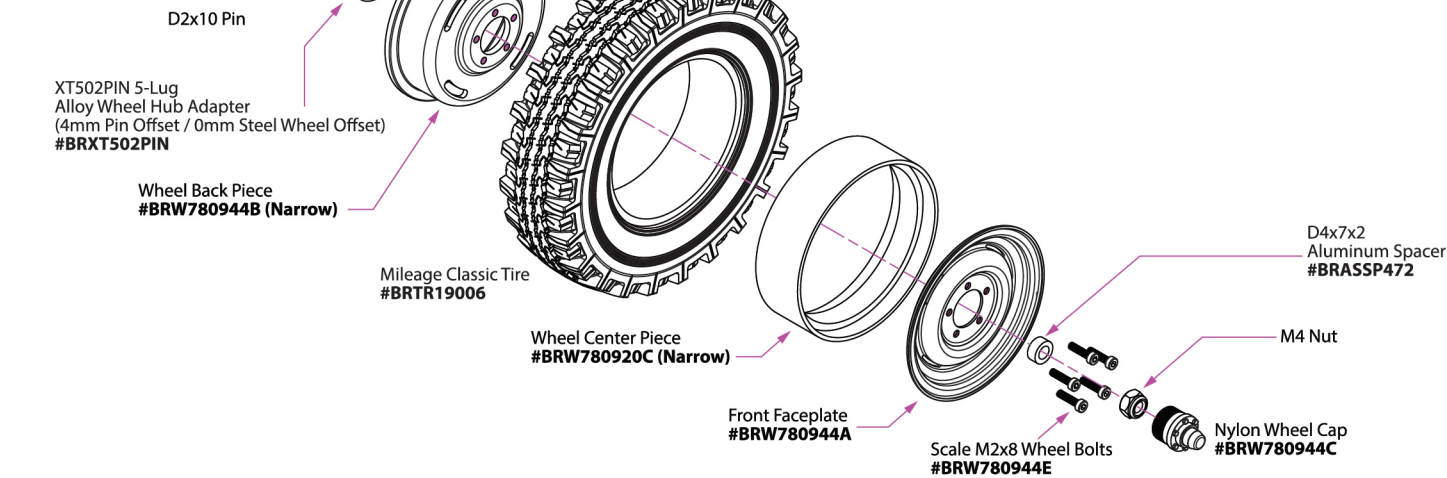
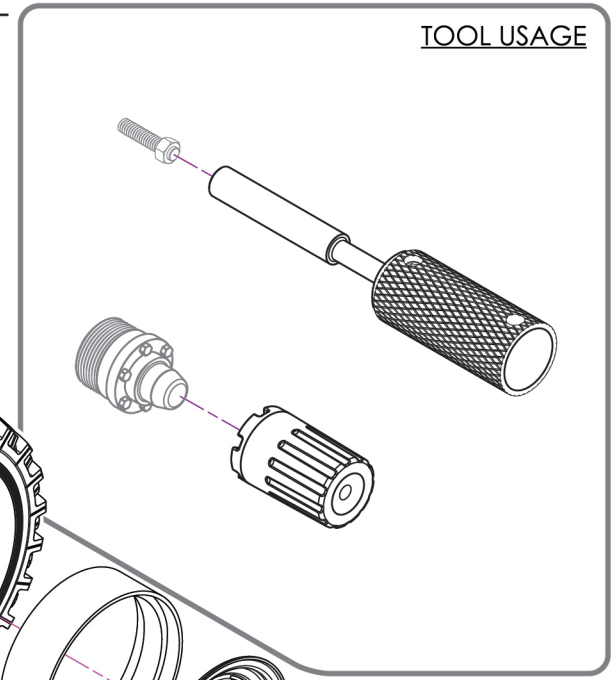
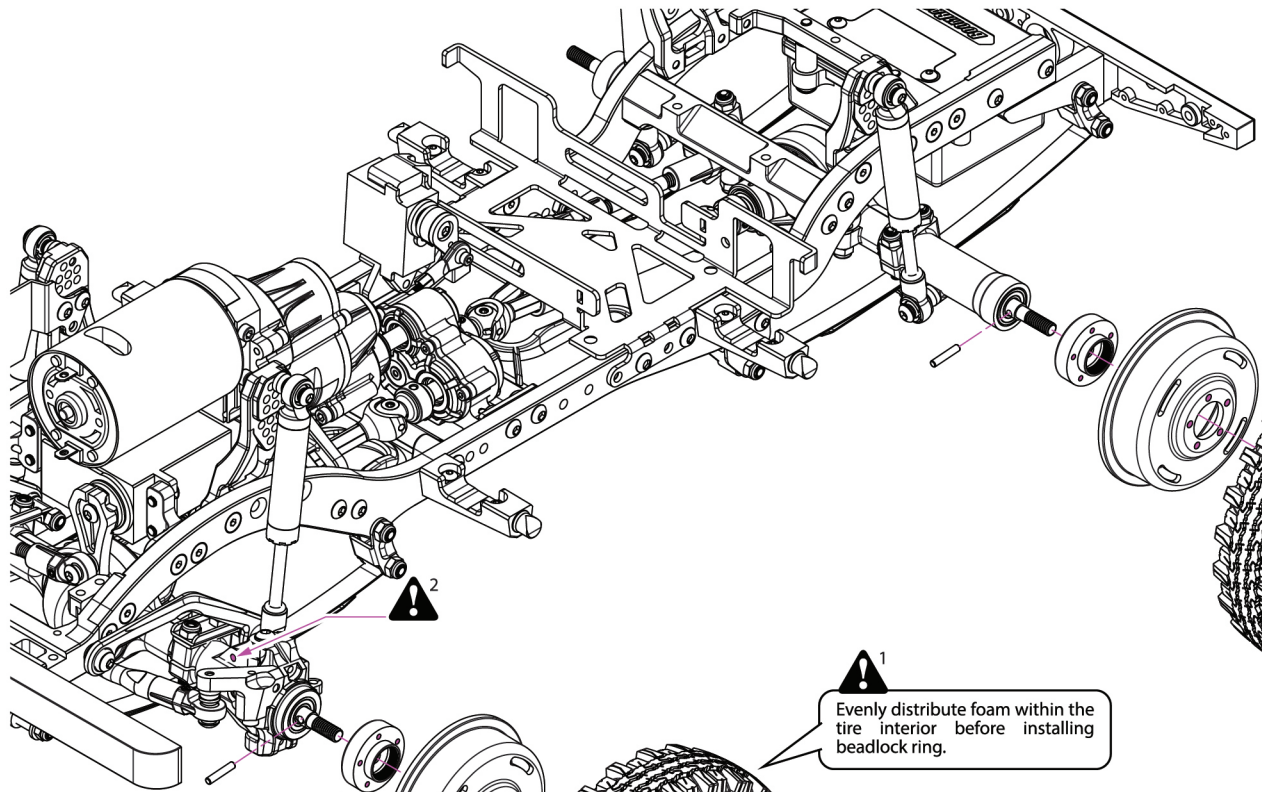

18 - REAR BUMPERETTE INSTALLATION

Parts Needed:

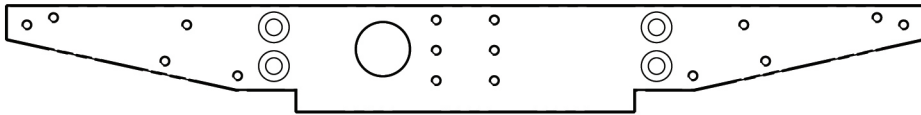

Rear Bumper x 1
#BRX020109R



Rear Bumper Guard x 2

J GEARS, SHAFTS & BEARINGS - GEAR BOX



M2x9 Scale Hex Bolt x 4
#BRPROB-06BK



2.0mm Socket Driver Bit X 1

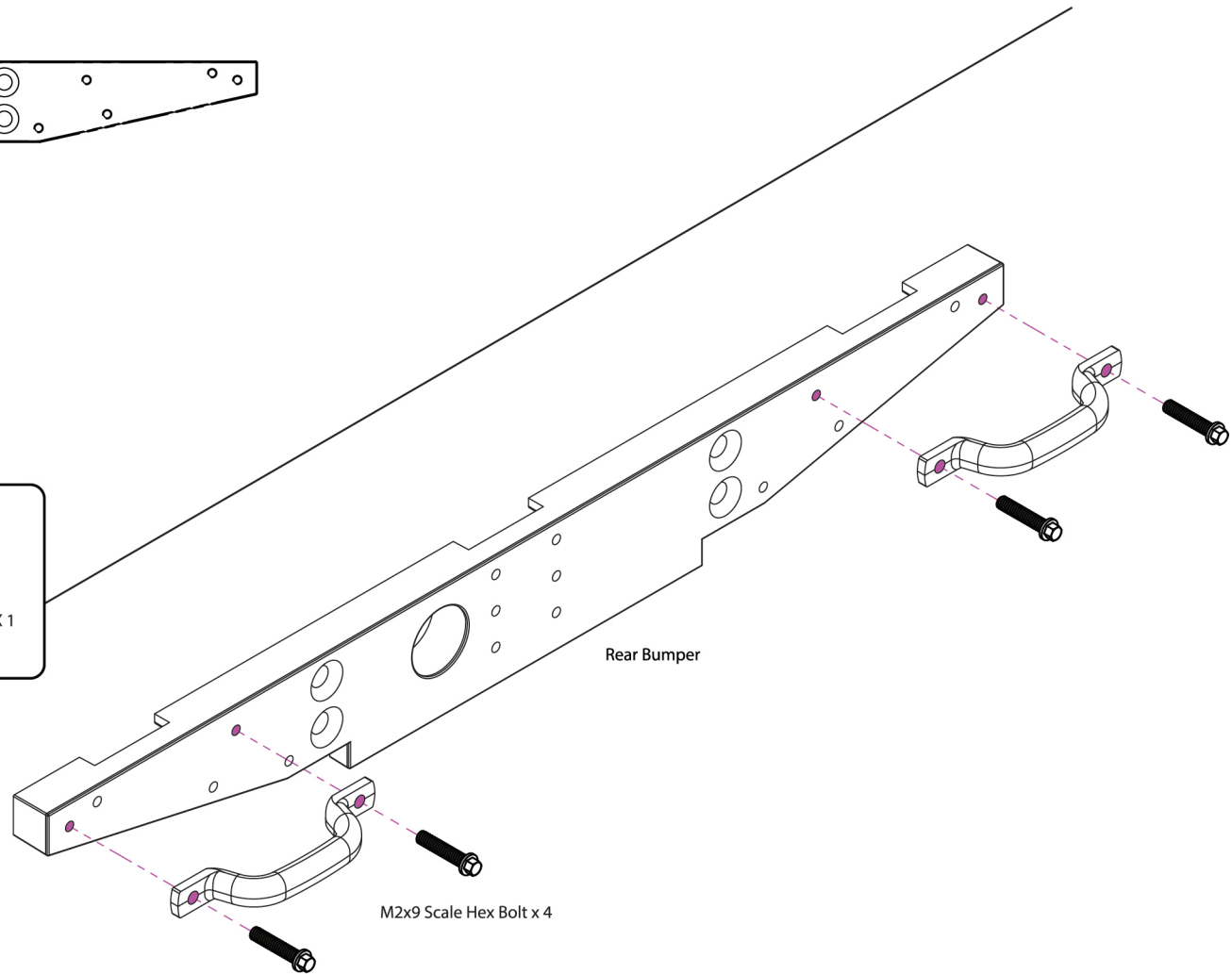

17 - BODY MOUNT

Parts Needed:

#BRX020112

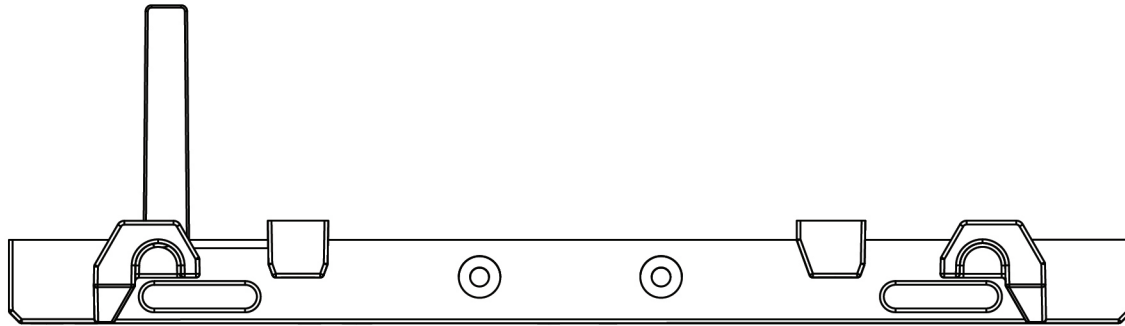

Aluminum Body Brace Left x 1

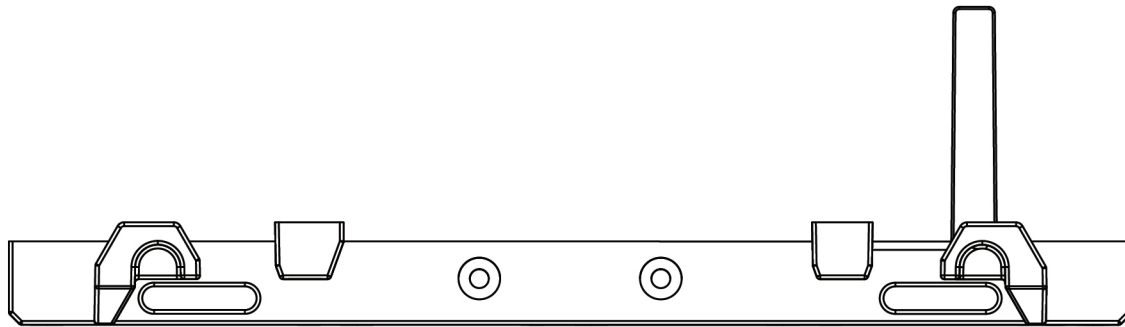

Aluminum Body Brace Right x 1

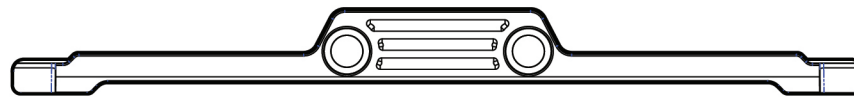
Quick Release Body Latch x 2
#BRX020061**G** BODY MOUNTS
 M3x14 RS x 4
#BRASBH3014

 Ø5mm Spring x 4
#BRASSPRING05510

 Slider Spacer x 4
#BRX020035

QUICK RELEASE BODY MOUNT - LEFT

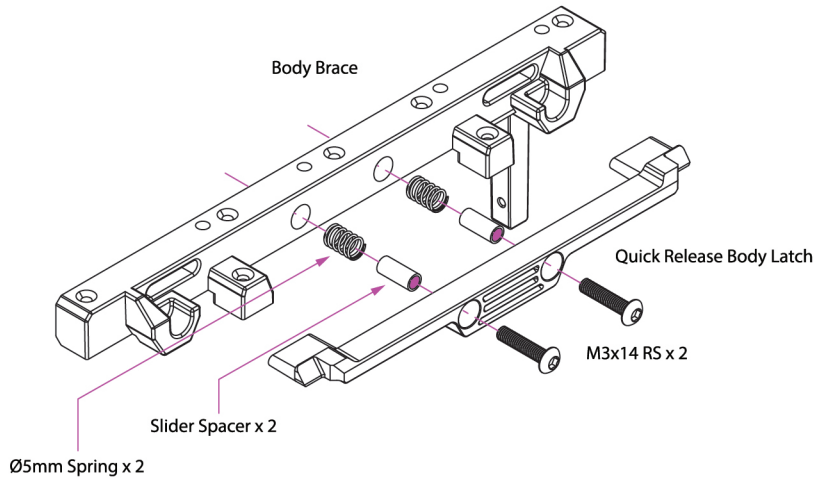

QUICK RELEASE BODY MOUNT - RIGHT

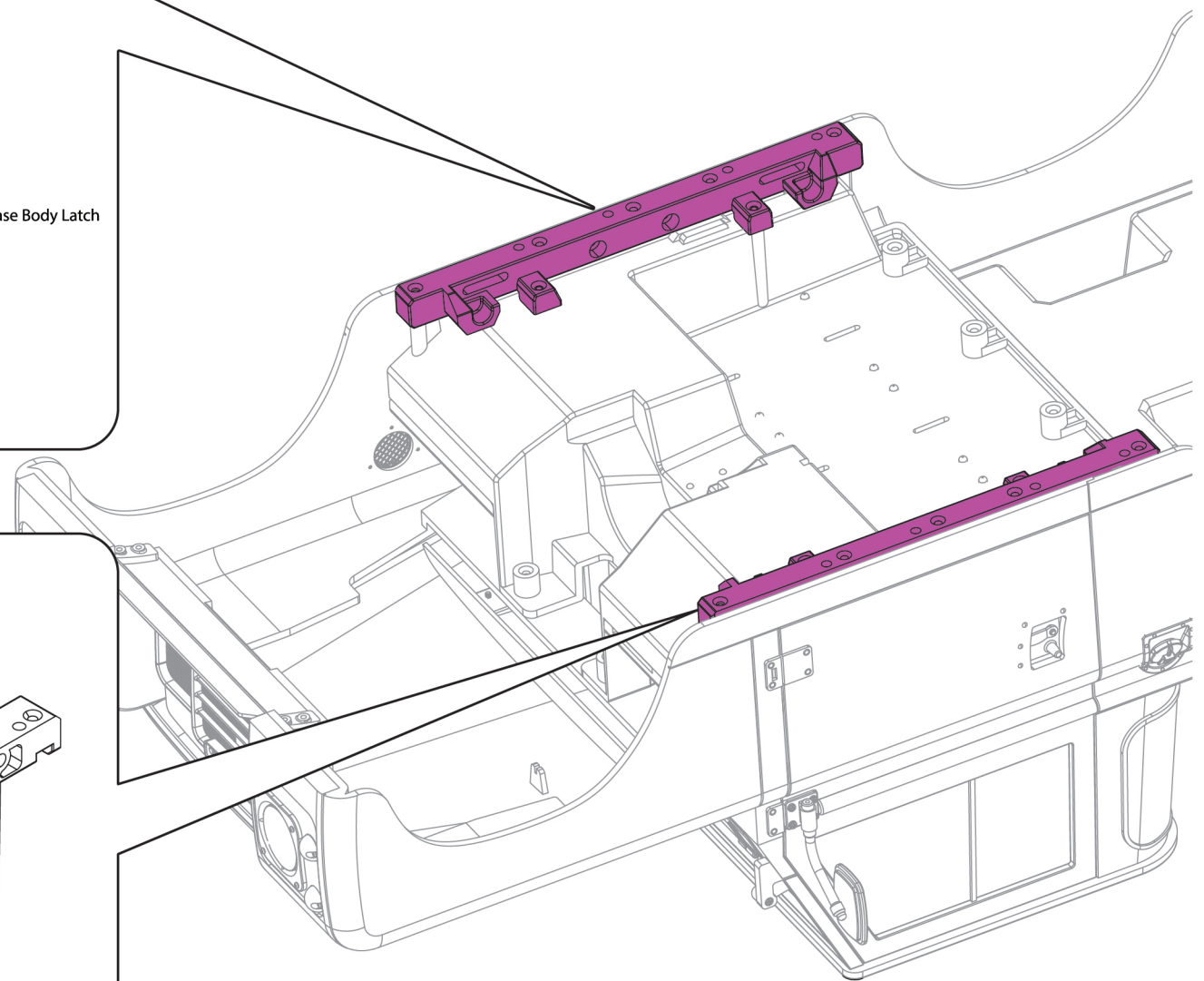
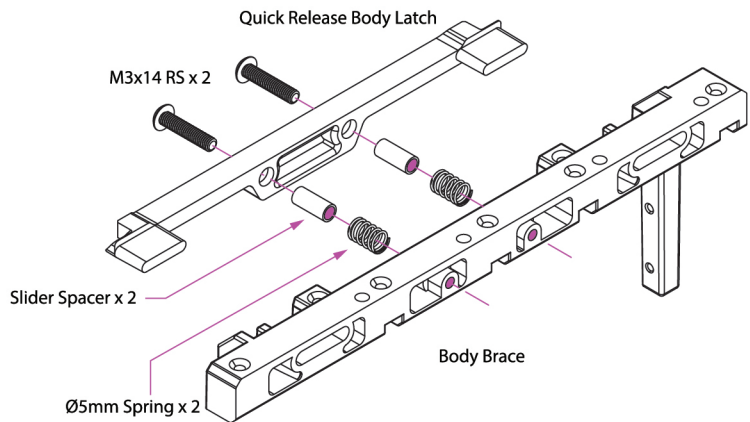

BODY MOUNT

BODY MOUNT

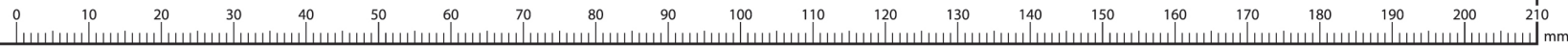

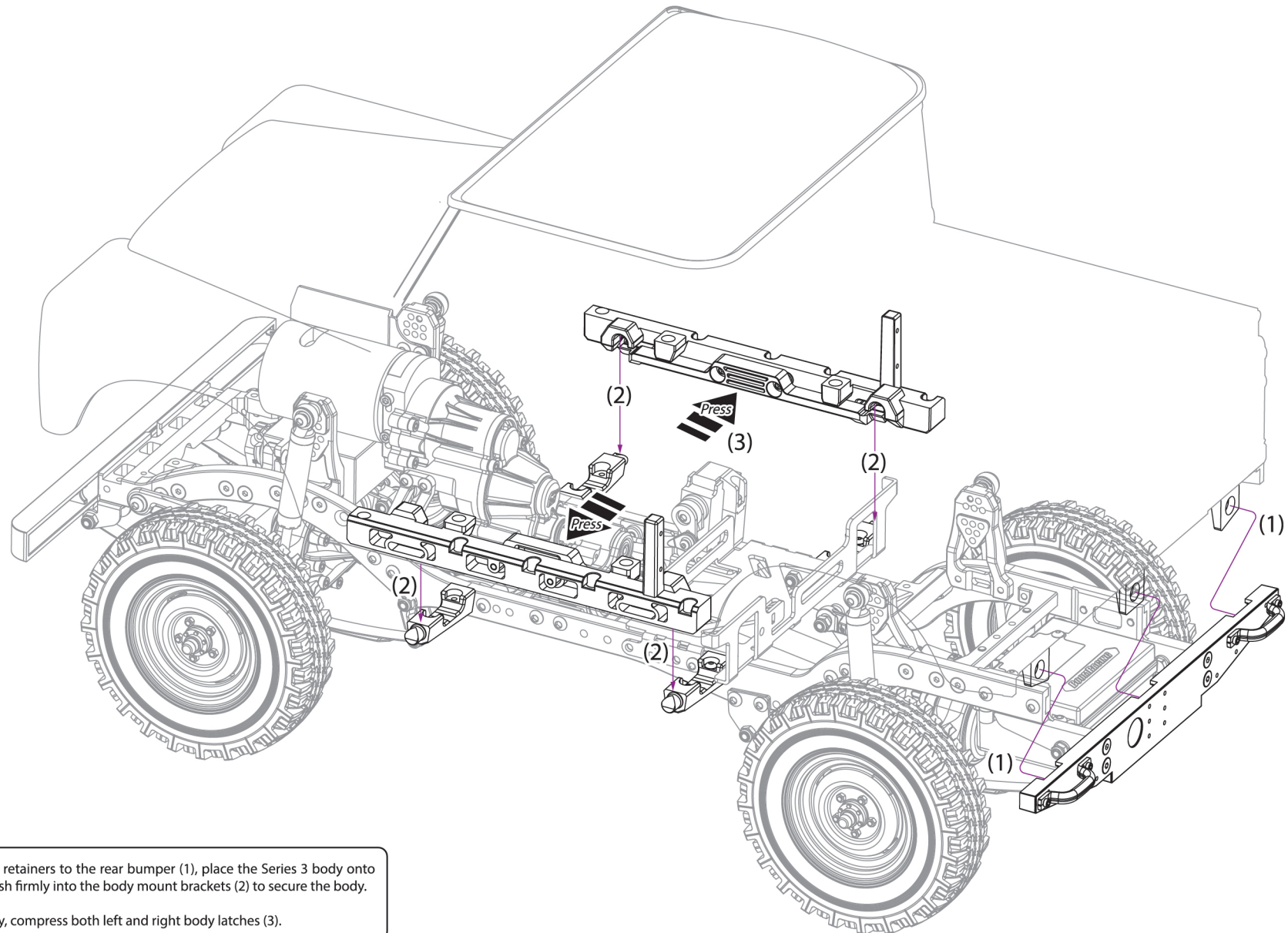
ATTACH / DETACH BODY

After inserting the retainers to the rear bumper (1), place the Series 3 body onto the chassis and push firmly into the body mount brackets (2) to secure the body.

To release the body, compress both left and right body latches (3).

PRE-ASSEMBLED AXLE

Front Diff Cover Release Method In Case Assembly Is Tight.

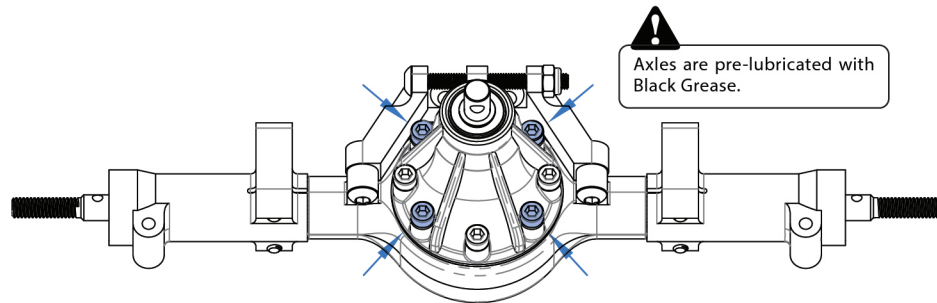

Step 1 - Loosen four M2.5x16mm socket screws indicated making the screw cap 3 mm apart from the case.

Step 2 - Hammer those screw slightly via screwdriver to release the front diff cover.

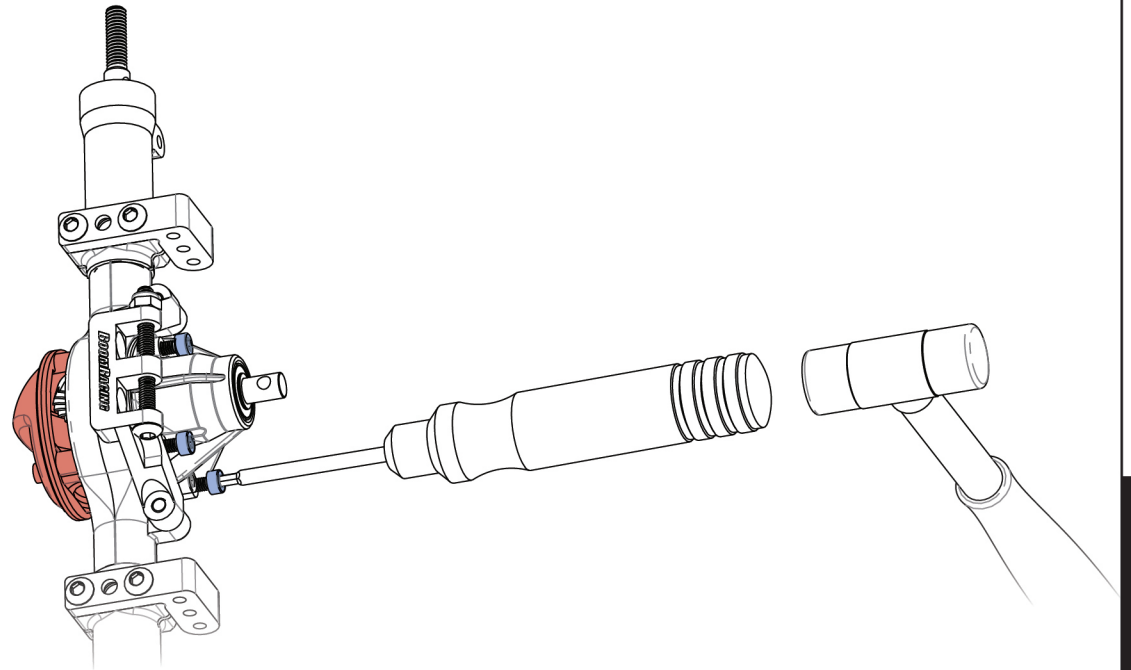

The Third Member Release Method When Assembly Is Tight.

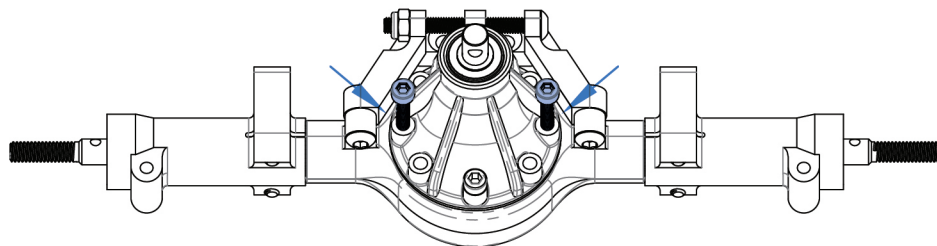



Step 1 - Remove all M2.5x16mm and two M2.5x5mm socket screws

Step 2 - Install two M2.5x16mm socket screws into both left and right screw holes as indicated

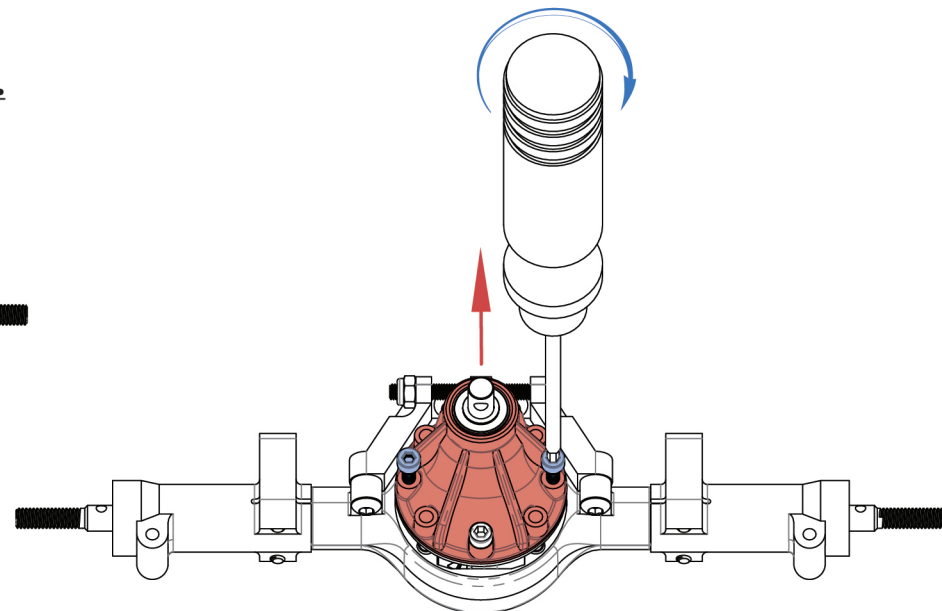
Step 3 - Lightly torque the screws until the third member is released



PRE-ASSEMBLED FRONT AXLE

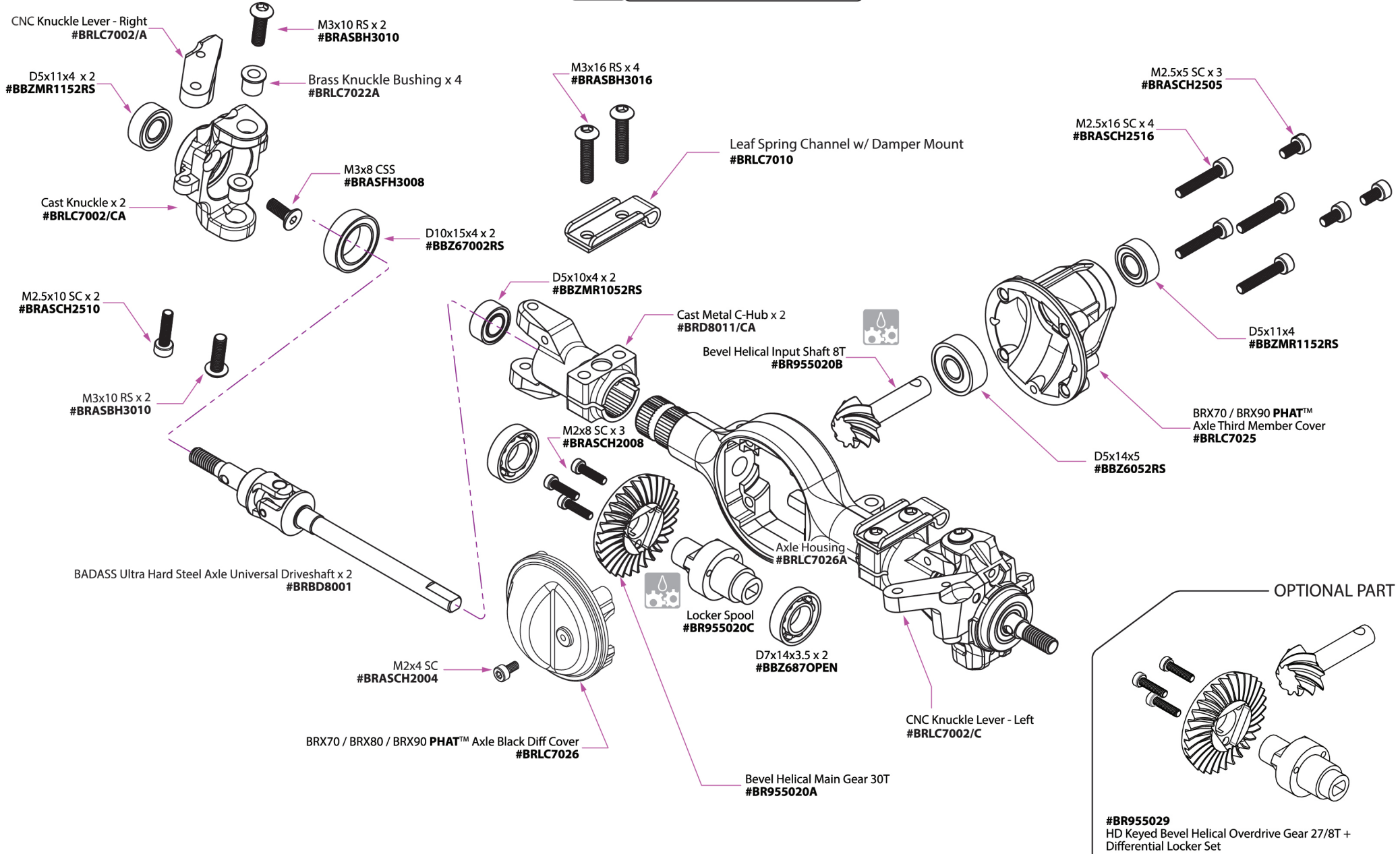

  Apply a generous amount of Black Grease on all movable contact surfaces including gears, spacers, shafts and bearings.



PRE-ASSEMBLED PARTS

PRE-ASSEMBLED PARTS

PRE-ASSEMBLED REAR AXLE

  Apply a generous amount of Black Grease on all movable contact surfaces including gears, spacers, shafts and bearings.

PRE-ASSEMBLED PARTS

PRE-ASSEMBLED PARTS

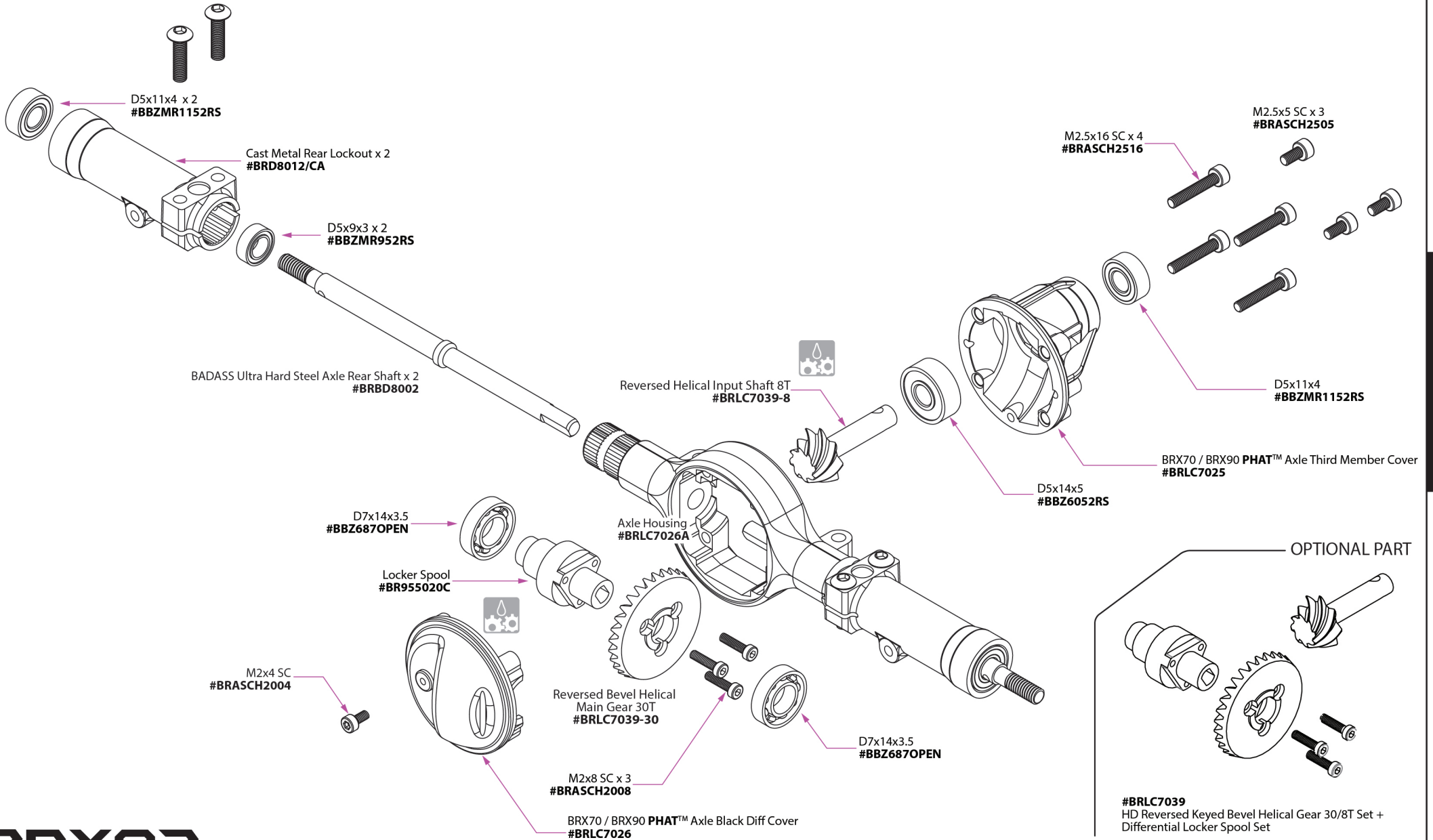

PARTS LIST

Part #	Description	Part #	Description
BBZ6052RS	5x14x5mm High Performance Rubber Sealed Bearing (1)	BRASSPD471/N	D4x7x1 Nylon Spacer (5)
BBZ67002RS	10x15x4mm High Performance Rubber Sealed Bearing (1)	BRASSPD4705	Spacer D4x7x0.5 (5)
BBZ687OPEN	7x14x3.5mm High Performance Open Ball Bearing (1)	BRASSPD5801	Spacer D5x8x0.1 (10)
BBZMR1052RS	5x10x4mm High Performance Rubber Sealed Bearing (1)	BRASSPD5805	Spacer D5x8x0.5 (10)
BBZMR1152RS	5x11x4mm High Performance Rubber Sealed Bearing (1)	BRASSPD5730	Spacer D5x7x3 (5)
BBZMR1172RS	7x11x3mm High Performance Rubber Sealed Bearing (1)	BRASSPRING05510	Ø5mm Spring (4)
BBZMR952RS	5x9x3mm High Performance Rubber Sealed Bearing (1)	BRASST3003	M3x3 Set Screw (10)
BR955014BK	Aluminum Short Low Profile Servo Horn 25T Black	BRASST3004	M3x4 SS Set Screw (10)
BR955020	Heavy Duty Keyed Bevel Helical Gear 30/8T + Differential Locker Spool Set	BRASST3022/DS	M3/2.2x11 Set Screw (10)
BR955020A	Heavy Duty Bevel Helical Main Gear 30T	BRASST3024/DS	M3/2.4x11 Set Screw (10)
BR955020B	Heavy Duty Bevel Helical Input Shaft 8T	BRASST4016	M4x16 Set Screw (10)
BR955020C	Diff Locker Spool for HD Helical Bevel Gear	BRBD8001	Ultra Hard Steel Axle Universal Driveshaft (2)
BR955029	Heavy Duty Keyed Bevel Helical Overdrive Gear 27/8T + Differential Locker Set	BRBD8002	Ultra Hard Steel Axle Rear Shaft (2)
BRASBH2504	M2.5x4 RS Round Head Screw (10)	BRD8011/CA	Cast Metal C-Hub (2)
BRASBH2506	M2.5x6 RS Round Head Screw (10)	BRD8012/CA	Cast Metal Rear Lockout (2)
BRASBH2514	M2.5x14 RS Round Head Screw (10)	BRD8022A	Stainless Steel Tie Rod For BRX80 axle
BRASBH3006	M3x6 RS Round Head Screw (10)	BRGRS01	BADASS™ Siliking Grease 5g
BRASBH3008	M3x8 RS Round Head Screw (10)	BRGRS08	BADASS™ Black Graphite Grease 5g
BRASBH3010	M3x10 RS Round Head Screw (10)	BRGRS09-5GB	BADASS™ Shock Slime Grease 5g
BRASBH3012	M3x12 RS Round Head Screw (10)	BRGRS10274-10	BADASS™ Silicone Grease 10g
BRASBH3014	M3x14 RS Round Head Screw (10)	BRGRS10274-20	BADASS™ Silicone Grease 20g
BRASBH3016	M3x16 RS Round Head Screw (10)	BRGRS1055-10	BADASS™ Black Graphite Grease 10g
BRASBH3022	M3x22 RS Round Head Screw (10)	BRGRS1055-20	BADASS™ Black Graphite Grease 20g
BRASBH3024	M3x24 RS Round Head Screw (10)	BRGRS242	242 Blue Thread Lock 10g
BRASCH2004	M2x4 SC Socket Cap Screw (10)	BRLC7002/A	Aluminum Knuckle Lever (High Clearance) - Right
BRASCH2008	M2x8 SC Socket Cap Screw (10)	BRLC7002/C	Aluminum Knuckle Lever (High Clearance) - Left
BRASCH2505	M2.5x5 SC Socket Cap Screw (10)	BRLC7002/CA	Cast Metal Knuckle (2)
BRASCH2506	M2.5x6 SC Socket Cap Screw (10)	BRLC7010	Steel Leaf Spring Channel w/ Shock Mount for BRX70 / BRX80 / BRX90 Axle (2)
BRASCH2508	M2.5x8 SC Socket Cap Screw (10)	BRLC7022A	Brass Bushing for BRX70 / BRX80 / BRX90 Axle Knuckle (4)
BRASCH2510	M2.5x10 SC Socket Cap Screw (10)	BRLC7025	BRX70 / BRX80 / BRX90 PHAT™ Axle Third Member Cover
BRASCH2516	M2.5x16 SC Socket Cap Screw (10)	BRLC7026	BRX70 / BRX80 / BRX90 PHAT™ Axle Black Diff Cover
BRASCH3008	M3x8 SC Socket Cap Screw (10)	BRLC7026A	BRX70 / BRX80 / BRX90 PHAT™ Axle Housing
BRASEC30	E-Clip 3mm (10)	BRLC7027	Aluminum Gearbox Adapter w/ Motor Mount
BRASFH2005	M2x5 CSS Counter Sunk Screw (10)	BRLC7029-12T	Heavy Duty 12T Spur Gear
BRASFH2508	M2.5x8 CSS Counter Sunk Screw (10)	BRLC7029-15T	Heavy Duty 15T Spur Gear
BRASFH3006	M3x6 CSS Counter Sunk Screw (10)	BRLC7029-20T	Heavy Duty 20T Spur Gear
BRASFH3008	M3x8 CSS Counter Sunk Screw (10)	BRLC7029-24T	Heavy Duty 24T Spur Gear
BRASFH3010	M3x10 CSS Counter Sunk Screw (10)	BRLC7029-32T	Heavy Duty 32T Spur Gear
BRASHS3005	M3x5 Hex Cap Screw (2)	BRLC7030	Spur Gear Mount
BRASNUTM25	Nut M2.5 (5)	BRLC7031	Internal Spur Gear 28T
BRASNUTM3	Lock Nut M3 Nyloc (5)	BRLC7032	Steel Motor Spacer
BRASNUTM4	Lock Nut M4 Nyloc (5)	BRLC7033	BRX Universal Receiver Box Set w/ Silicone Seals
BRASPIN210	D2x10 Pin (10)	BRLC7033A	Silicone Seal & Port for BRX Receive Box
BRASSP473	D4x7x3 Aluminum Spacer (5)	BRLC7039	30/8T Reverse HD Steel Triangular Keyed Bevel Helical Cut Diff Gear w/ Spool Set
		BRLC7039-8	HD Steel Reversed Helical Input Shaft 8T

PARTS LIST

Part #	Description
BRLC7039-30	HD Steel Reversed Bevel Helical Main Gear 30T
BRLC7041	M3x6x3 Tapper Spacer (4)
BRLC7044	Ultra Hard Steel Gearbox Shaft Set (3pcs)
BRLC7044A	Ultra Hard Steel Gear Catcher
BRLC7044B	Input shaft
BRLC7044C-EX	Extended Gearbox Output Shaft
BRLC7044E	2-Speed Gear Unit
BRLC7045A	Brass Shifter Cap & Bushing
BRLC7045B	Ultra Hard Steel Shifter
BRLC7045C	Stainless Steel Shift Rod
BRLC7049	Mini Servo Horn
BRLC7050	Fine Tunable Link
BRLC7060	2-Speed Gear Circle Clip (5)
BRLC7064A	Leaf Spring Set (2)
BRLC7064C	Stainless Steel M4X40 Anti-wrap Bar (2)
BRLC7064D	Rear Shackles (2)
BRLC7064E	M3x14 Bolt
BRLC7064F	Rear Leaf Retainer (Outside & inside) (2)
BRLC7095	Extension Cable (2)
BRLC7207-P	Guiding Shaft (1)
BRLC7208	Rear Output Shaft For OD & SWD Transfer Case
BRLC70201-B	Front Output Shaft For OD & SWD Transfer Case
BRLC70201-GEAR	Over-drive Gear Set
BRLC70210	Gear Set 20Tx1 29Tx2 For SWD Transfer Case
BRPG3212-3	32P 12T / 3.175mm Steel Pinion Gear
BRPROB-17	ProBuild™ 3.0mm Socket Driver Thumb Tool
BRQ90351	D2 Ball & Rod End
BRRM19006	Rock Monster RED Silicone Tire Insert 3.5"x0.84" (90x21mm)
BRSJ0080	KUDU™ 80mm Scale Shock Absorber (2)
BRSJHR	Pivot Ball Retainer (4)
BRSORD6-15	D6x1.5 O-Ring (10)
BRT10037	Cable Wiring Retainer
BRT10028	Tool Kit
BRT10053	Pivot Ball Tool
BRTR19006	1.9" Mileage Classic™ Scale Crawler Tire GEKKO Compound 3.82"x1.0" (97x26mm) w/ Single Stage Open Cell Foam (2)
BRTR39005	Single Stage Open Cell Foam Insert for 1.9" Mileage Classic™ Crawler Tire 3.82"x0.94" (97x24mm) (2)
BRW750300	BADASS™ Stainless Steel Pivot Ball (10)
BRW750306A	KUDU™ HD Rust-Resistant Rod Ends M4 Nylon (Straight) 18.5mm w/ SST Pivot Ball (5.8x3x7.4mm) (10)
BRW750308C	KUDU™ HD Rust-Resistant M4 Nylon Rod Ends 19.5mm (Sideways) w/ SST Pivot Ball (5.8x3x7.4mm) (10)
BRW750309B	KUDU™ HD Rust-Resistant Rod Ends M4 Nylon (Straight) 21.8mm w/ SST Pivot Ball (5.8x3x7.4mm) (10)

Part #	Description
BRW750310	Shock End Pivote Ball (4)
BRW780920C	Wheel Center Piece (Narrow)
BRW780944	SLR™ 1.9 Classic Steel Wheel w/cap and Scale Hardware (4)
BRW780944A	SLR™ Wheel Face Plate (2)
BRW780944B	SLR™ Wheel Barrel (2)
BRW780944C	Nylon Wheel Cap (4)
BRW780944D	Wheel Cap Installation Tool (1)
BRW780944E	M2x8 Scale Wheel Bolt (5)
BRX020012	Rear Crossmember
BRX020014	Mid Crossmember
BRX020016	Front Crossmember
BRX020018F	Front shock Mount (Left & Right)
BRX020018R	Rear Shock Mount (Left & Right)
BRX020020LF	Center Skid Plate
BRX020027	Front Anti-wrap Bar (2)
BRX020029	BCF2™ Gearbox Housing (A & B)
BRX020029A	Gear Box Bearing Holder
BRX020030	Brass Washer (4)
BRX020034	Body Latch Pin (4)
BRX020035	Slider Spacer (4)
BRX020039	Body Post (4)
BRX020055	Cast C-Hub (2)
BRX020056	Cast Lock Out (2)
BRX020064A	Front Shackle (2)
BRX020064B	Front Leaf Retainer (Left & Right)
BRX020106	Steel Front ESC Mount Plate
BRX020108	Steering Servo Mount (Left & Right)
BRX020109F	Series 3 Aluminum Front Bumper
BRX020109R	Series 3 Aluminum Rear Bumper
BRX020110	Gearbox Side Mount (Left & Right)
BRX020111	B2X™ Transfer Case Housing
BRX020112	Quick Release Body Mount for Series 3 (Left & Right)
BRX020113	S3 Rear Bumperette (2)
BRX020115F	BRX80 Complete Front PHAT™ Axle LEAF Ver.
BRX020115R	BRX80 Complete Rear PHAT™ Axle LEAF Ver.
BRX0290011	Aluminum Chassis Rail for S3 88 (Left & Right)
BRX0290012	Mini Servo Mount
BRX0290016	Receiver Box Post D3x6x9
BRX0290107F	Nylon Center Front Skid Slider
BRX0290107R	Nylon Center Rear Skid Slider
BRX029019	Rear Bumper Mount (Left & Right)
BRX029021	Battery Tray
BRX029043	HD CVD Center Drive Shaft (Front & Rear)
BRX029051	Shift Rod
BRXT502PIN	Scale M2x8 Wheel Bolt (5)
JX/PDI-HV1151MG	JX Waterproof High Voltage Mini Servo

PARTS LIST (Optional Accessories)

Part #	Description	Part #	Description
Overdrive Gears		Bearing Set	
BR955029	Overdrive HD Steel Keyed Bevel Helical Gear 27/8T & Diff Locker Spool Set	BRX01BBZ	High Performance Full Ball Bearings Set Rubber Sealed (32 Total)
BR955029A	Overdrive HD Bevel Helical Main Gear 27T for BR955029	BRX01FABBZ	High Performance Ball Bearings Set Rubber Sealed For Front Axle (10 Total)
BR955029B	Overdrive HD Bevel Helical Input Shaft 8T for BR955029	BRX01GBBBZ	High Performance Ball Bearings Set Rubber Sealed For Gearbox (8 Total)
Pinion Gear		BRX01RABBZ	High Performance Ball Bearings Set Rubber Sealed For Rear Axle (8 Total)
BRPG3209-3	32P 9T / 3.175mm Steel Pinion Gear (1)	BRX02TMBBZ	High Performance Ball Bearings Set Rubber Sealed For B2X ™ Transfer Case (6 Total)
BRPG3210-3	32P 10T / 3.175mm Steel Pinion Gear (1)		
BRPG3211-3	32P 11T / 3.175mm Steel Pinion Gear (1)		
BRPG3212-3	32P 12T/3.175 Steel Pinion Gear (1)		
BRPG3213-3	32P 13T / 3.175mm Steel Pinion Gear (1)		
BRPG3214-3	32P 14T / 3.175mm Steel Pinion Gear (1)		
BRPG32COMBO1-3	32P Steel Pinion Gear Combo 9T-12T (4)		
BRPG32COMBO2-3	32P Steel Pinion Gear Combo 13T-16T (4)		
Shock Oil			
BRSHK010	BADASS ™ Silicone Shock Oil 10wt 60ml		
BRSHK015	BADASS ™ Silicone Shock Oil 15wt 60ml		
BRSHK020	BADASS ™ Silicone Shock Oil 20wt 60ml		
BRSHK025	BADASS ™ Silicone Shock Oil 25wt 60ml		
BRSHK030	BADASS ™ Silicone Shock Oil 30wt 60ml		
BRSHK035	BADASS ™ Silicone Shock Oil 35wt 60ml		
BRSHK040	BADASS ™ Silicone Shock Oil 40wt 60ml		
BRSHK045	BADASS ™ Silicone Shock Oil 45wt 60ml		
BRSHK050	BADASS ™ Silicone Shock Oil 50wt 60ml		
BRSHK055	BADASS ™ Silicone Shock Oil 55wt 60ml		
BRSHK060	BADASS ™ Silicone Shock Oil 60wt 60ml		
BRSHK065	BADASS ™ Silicone Shock Oil 65wt 60ml		
BRSHK070	BADASS ™ Silicone Shock Oil 70wt 60ml		
BRSHK075	BADASS ™ Silicone Shock Oil 75wt 60ml		
BRSHK080	BADASS ™ Silicone Shock Oil 80wt 60ml		

If you have questions, call Boom Racing at:
 1-209-676-8880 (USA) or email Boom Racing at sales@boomracing.com

WWW.BOOMRACING.COM

Brian Parker - Recon G6

When "Enjoy Being a Badass" is a slogan, you better bring it. Boom Racing does just that; they are the pinnacle of R/C scale performance. The BRX01 shattered the perception that scale R/C meant sacrificing performance. The platform didn't change the game; it created the scale performance game and left other manufacturers watching from the park bench outside the stadium of awesomeness. The BRX02 Land Rover Series III continues this "badass" reputation and drives leaf-sprung performance and tunability into its own category. Not only in the quality of the product, and I mean from unboxing to engineering to the instruction manual to driving performance to creativity in owning an R/C vehicle. This level of thinking tells me one essential thing about Boom Racing as a company: Jason Tsang & his colleagues do not see people as customers; Boom Racing is building a community of scale performance-minded individuals.

Dariusz Cybula - RC/DC Scale RC

When building R/C models, I aim to make them good enough to look and function like a real car. It is not easy and sometimes seems unattainable. Typically, the models offered on the market did not provide such an option and required many changes, combinations, and searches. Now, this Series III has everything I want from an R/C model. A realistic and fully functional design that we can enjoy during construction. We no longer have to focus on modifications and wonder what to change to make it like the original. I appreciate this model's details and can always add something from myself. After all, this is what our hobby is all about.

Adam Sajdak - Maxee RC

Let me start by saying that driving the new Series III is pure pleasure! I was afraid of this model in the beginning because it is built on leaf springs. I was surprised when I saw it has axle supports with full configuration of the hardness of the leaf springs. The suspension works great, and the ride is very realistic. I'm very happy that we get two versions in one go; the standard Series III pickup with hard top, and the possibility of building a Safari version with a small door and without the roof. Plus, the windshield folding down on the hood is original. Such flavors in the kit are really first league. The model itself is very well made, with attention to details. I am delighted with this model!

Shawn Roche

This truck has it all - a beautifully done iconic body, a leaf spring chassis that actually performs, and the tried and true BRX drivetrain. With this kit Boom Racing has set the bar for excellence higher than I thought possible.

Jeremy Kilburn

Having built hundreds of R/C kits over the years, the BRX02 109 was a fantastic experience and a top tier kit. It was a true pleasure to assemble a well-engineered and well thought out kit. There was never a moment I wished for more, all the metal and machined parts will keep this vehicle dependable and durable for many years to come.



BOOMRACING  [®]
Your Radio Control Car Specialist

BRX02

BRX02 88 1/10 4WD R/C CHASSIS KIT FOR SERIES LAND ROVER

WWW.BOOMRACING.COM