

SCALE **4WD** Series

**BOLT-ON KIT**  
PARTIAL ASSEMBLY REQUIRED

**BOOMRACING**  
Your Radio Control Car Specialist

# BRX01

1/10TH 4WD RADIO CONTROL CHASSIS KIT FOR LC70

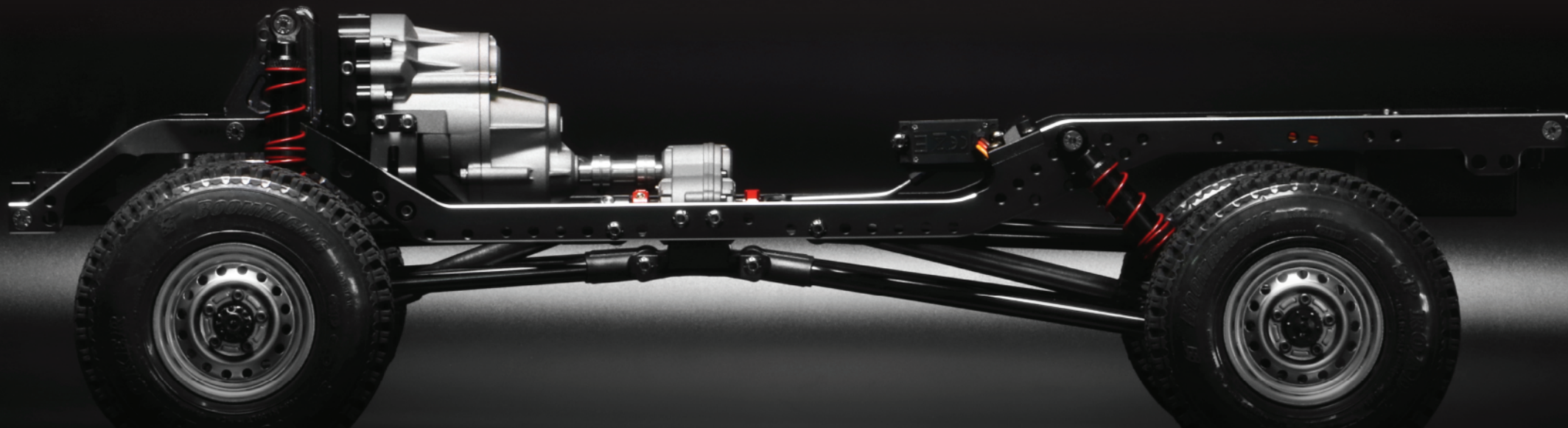

# BRX01

1/10TH 4WD RADIO CONTROL CHASSIS KIT FOR LC70

**BOOMRACING**  
Your Radio Control Car Specialist

## HOW IS THE BRX01 DIFFERENT?

Starting with a clean sheet of paper the 1/10 BRX01 was developed as a performance based R/C crawler chassis with a scale "stock truck" appearance. It combines many performance and scale features into a single ground breaking vehicle.

What makes the BRX01 special is that many of the features on the chassis come from the imaginations of fellow R/C hobbyists. By listening to their ideas and feedback, we are able to include many new and exciting features into the BRX01.

This is what Boom Racing has always been about - involving our community to push innovations forward.

## ENJOY BEING A BADASS!

## Wie unterscheidet sich das BRX01 von anderen Chassis?

Beginnend mit einem leeren Blatt Papier, wurde das 1/10 BRX01 als performance basiertes RC-Crawler Chassis mit möglichst realistischer Scale Optik entwickelt. Es vereint viele Performance- und Scaleeigenschaften in einem einzigen bahnbrechenden Scaler.

Das Besondere an dem BRX01 ist, dass viele Funktionen des Chassis auf Vorstellungen und Wünsche anderer RC-Hobbyisten basieren. Wir haben Euch zugehört und möglichst viele Eurer Ideen und Feedbacks bei der Konstruktion des BRX01 berücksichtigt und in das Chassis integriert.

Darum ging es uns bei Boom Racing schon immer - die Einbindung unserer Community in die Entwicklung um Innovationen voranzutreiben.

## ENJOY BEING A BADASS!

## En quoi le BRX01 est si différent ?

Issu d'une page blanche, Le BRX01 1/10 a été développé sur une base performante avec son châssis de crawler et un look de véhicule de série très réaliste.

La combinaison de ses nombreuses performances et fonctionnalités en font un véhicule révolutionnaire.

Les spécificités du BRX01 proviennent du fait que son châssis est né de l'inspiration de l'équipe de Boom Racing avec la contribution des passionnés de modélisme.

Le savant mélange des idées de l'équipe, combiné aux retours des passionnés a permis d'inclure de nombreuses fonctionnalités innovantes.

C'est là tout l'esprit "BADASS" de Boom Racing : impliquer la communauté des passionnés dans l'innovation !

## ENJOY BEING A BADASS!

## ¿En qué se diferencia el BRX01?

Comenzando con una hoja de papel limpia, el 1/10 BRX01 se desarrolló como un chasis de Crawler de R / C basado en el rendimiento con una apariencia "stock".

Combina muchas características de rendimiento y escala en un único chasis innovador. Lo que hace que el BRX01 sea especial es que muchas de las características del chasis provienen de la imaginación de otros aficionados de R / C. Al escuchar sus ideas y comentarios, pudimos incluir muchas características nuevas y emocionantes en el BRX01. De esto se ha tratado Boom Racing: "involucrar a nuestra comunidad para impulsar innovaciones."

## ¡DISFRUTE Siendo BADASS!

## Como é que o BRX01 é diferente?

Começando com uma folha de papel limpa o BRX01 foi desenvolvido baseado na performance de um chassi de R/C crawler, mantendo uma aparência stock.

Combina muitas características de performance e aparência realística num único chassi inovador. O que torna o BRX01 num chassi tão especial foi que muitas das características vieram da imaginação de membros apaixonados do mundo do R/C. Ouvindo as suas ideias e comentários foi possível incluir muitas características novas e emocionantes ao BRX01. É disto que a Boom Racing, como sempre se baseia: "envolver a nossa comunidade para promover o desenvolvimento de inovações".

## Diverte te sendo um rebelde!

## BRX01은 어떻게 다른가요?

아무것도 없는 도면으로 시작하여 1/10 BRX01은 "트럭 혈통"을 기반으로 하여 R/C 크롤러(트라이얼) 채시로 개발되었습니다. 여러 가지 성능 및 스케일의 기능을 채시에 결합 합니다. BRX01을 특별하게 만드는 이유는 채시의 많은 기능이 동료 R/C 애호가들의 상상력에서 비롯된 것입니다. 아이디어와 피드백을 듣고 BRX01에 새롭고 흥미로운 기능을 많이 추가 할 수 있었습니다. 이것이 바로 우리 블레이싱이 항상 혁신을 추구하는 것과 관련이 있습니다.

멋지게 즐기세요!

## BRX01与众不同

现在的遥控车市场上还没有一款同时兼具仿真与攀爬性能的车架。一个外观比例几乎接近于现实真车还同时兼备了许多优越攀爬性能的车架 -- BRX01，应运而生！BRX01从设计之初就定位在是一辆具备攀爬性能的仿真车。我们广泛听取了用户和一些顶级发烧友的建议和意见，把一些新的特性和现有的性能特点都巧妙地结合在这一款车架中。

Boom Racing 坚持服务于消费者，真诚地联合世界各地模友，以共同创新推动模型车发展为己任！

*尽情嗨起来吧！*

## BRX01與眾不同

現在的遙控車市場上還沒有一款同時兼具仿真與攀爬性能的車架。一個外觀比例幾乎接近於現實真車還同時兼備了許多優越攀爬性能的車架 -- BRX01，應運而生！BRX01從設計之初就定位在是一輛具備攀爬性能的仿真車。我們廣泛聽取了用戶和一些頂級發燒友的建議和意見，把一些新的特性和現有的性能特點都巧妙地結合在這一款車架中。

Boom Racing 堅持服務於消費者，真誠地聯繫世界各地玩家，以共同創新推動模型車發展為己任！

*ENJOY BEING A BADASS!*



A Bolt-On Kit means parts of the chassis are pre-assembled and require minor assembly for completion. Factory-assembled components allow builders to get started more quickly while still enjoying the assembly experience. The BRX01 kit includes factory pre-built axles, transmission, transfer case and shocks. The shocks are factory assembled but require filling with the included shock oil before use.



The Scale 4WD Series is Boom Racing's line of scale based 4WD R/C products geared towards realistic appearance.

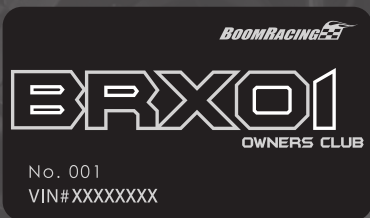

### Register Your BRX01

Every BRX01 chassis kit includes a unique chassis serial number, VIN, and BRX01 Owner's Card.

Registering your BRX01 confirms you as the original owner and allows Boom Racing to provide important product updates, warranty support, future service information, and exclusive owner benefits.

Your unique chassis serial number and VIN match those shown on your BRX01 Owner's Card, ensuring every chassis has its own identity.

We hope this registration program helps build a stronger community of BRX01 owners while preserving the history of every vehicle.

To register your BRX01, visit: <https://www.boomracingrc.com/vehicleregistration>

*FOR HOBBYISTS BY HOBBYISTS*



1/10TH 4WD RADIO CONTROL CHASSIS KIT FOR LC70



## ⚠ CAUTIONS ⚠

### BEFORE YOU PROCEED

Congratulations! Owning the BRX01 is a truly special experience.

Carefully read and follow all instructions to prevent serious damage to your model. Failure to follow these instructions will be considered abuse and/or neglect.

Study the instructions thoroughly before assembly.

There are many small screws, nuts and similar parts. Assemble them carefully referring to the drawings. Follow the steps exactly as shown to build the vehicle correctly without issues.

If you decide to return the BRX01, do not begin assembly. Your hobby dealer will not accept a model for return or exchange after you have started assembly.

Boom Racing offers spare parts and upgrade options to further enhance your BRX01. Visit our website or your local Boom Racing dealer for more information. Specifications, availability, and pricing are subject to change without notice.

### SAFETY PRECAUTIONS

All of us here at Boom Racing want you to enjoy your new truck. Operate your BRX01 sensibly and with care, and it will be exciting, safe and fun for you and those around you. Failure to operate your BRX01 in a safe and responsible manner may cause damage and injury.

Follow these outlined rules for safe radio control operation

- Read carefully and fully understand the instructions before assembly.
- This model is not intended for use by children (minors) under 14 years of age without the supervision of a responsible and knowledgeable adult who should also read the instructions.
- When assembling this kit, extra care should be taken to avoid personal injury. Keep out of reach of small children.
- Avoid running the vehicle in crowded areas and near small children.
- BRX01 can be very fast and quiet. It could cause injury to those unaware of its presence.

Inspect Your BRX01 Before and After Operation

- Make sure that all screws and nuts are properly tightened.
- Use thread lock on all screws that thread into metal.
- Adjust steering servo and trim so that the BRX01 runs straight with transmitter in neutral.
- Disconnect/remove all batteries after operation.
- Do not use batteries that are dented, swollen, damaged, or have frayed wires. Replace them immediately.
- Completely remove sand, mud, dirt etc after use to prolong the life of the BRX01.
- Maintain bearings by cleaning or replacing them regularly.

## WARRANTY

### Boom Racing's One (1) Year Factory Limited Warranty – A Peace Of Mind Right From The Start

#### WHO IS COVERED

This warranty is extended to the original end-user that registers it online (<https://www.boomracing.com>) only, whether purchased or received as a gift.

#### FACTORY LIMITED WARRANTY

##### What Is Covered and How Long

Boom Racing warrants that all new products are free from defects in manufacturing, materials and workmanship for a period of one (1) year from date of retail purchase. The receipt or invoice at the time of purchase is your proof of purchase and is required for Boom Racing to honor any warranty.

##### What Is Not Covered

It does not cover defects or malfunction caused by user error of assembly, damages due to normal wear and tear, failure to follow operating instructions, misuse or abuse, users' failure to perform routine maintenance, or use with products with which is not intended to be used. It also does not cover damages caused by unauthorized alteration, modification or repair. It does not cover cosmetic or incidental damages. Boom Racing does not warrant or provide service or support for any third party products.

The JX mini servo warranty will be void if it is disassembled.

##### What We Will Do

We will, at our discretion, repair or replace any product free of charge that is incorrectly made or proves to be defective in material or workmanship during the warranty period. If your product is no longer being manufactured or is out of stock, we may replace your product with a comparable or improved product at our option.

##### What We Will Not Do

We will not pay for shipping, insurance or transportation charges from you to us, or any import fees, duties and taxes.

##### What To Do To Obtain Warranty Service

To obtain warranty service for products purchased from a third-party, retail or directly from Boom Racing you must return the product with proof of purchase using the following procedures:

1. Contact Boom Racing Customer Support for specific warranty instructions via our website, by email or by telephone as follows:
  - Online @: <https://www.boomracing.com/contact-us>
  - Email: [sales@boomracing.com](mailto:sales@boomracing.com)
  - Telephone: 1-209-676-8880

You may be asked to complete a warranty service request form. A copy of your purchase receipt may be required.

2. Our Customer Support may ask you to return and ship the defective product back to us. Label and ship the product, freight prepaid, to the address provided by Boom Racing; and
3. Place any necessary return authorization number prominently on the outside of the return packaging. Return packaging not bearing a return authorization number where required may be refused.

Boom Racing reserves the right to make the final decision regarding all warranty claims.

## Equipment Required

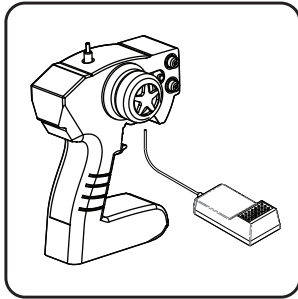

3CH Radio

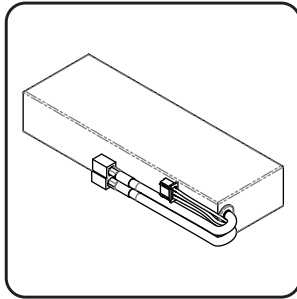

Battery

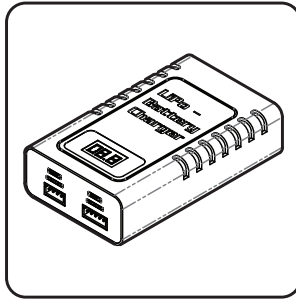

Charger

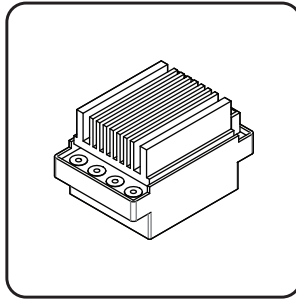

ESC

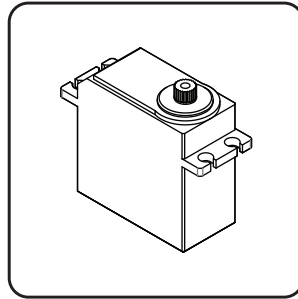

Steering Servo

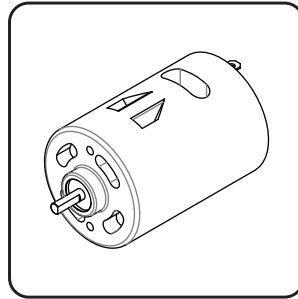

540/550 Motor

## Tools Recommended

1.5



2.0



KUDU™ Allen Hex Wrench Set  
#BRKT10020



Shock Slime Grease 5g  
#BGRS09-5GB

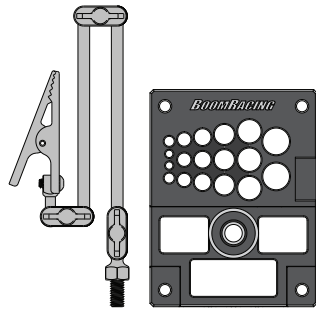

Multifunctional Soldering Jig  
#BRT10058

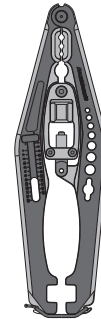

Multipurpose Shock Pliers  
#BRT10065

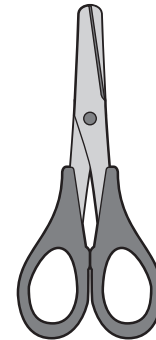

Scissors



Hobby Knife

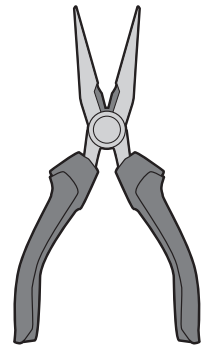

Long Nose Pliers

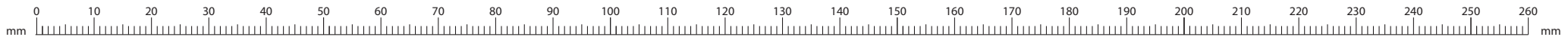

### Thread Lock Required

Apply thread lock to all screws threading into metal. Not required for nyloc nuts or screws threading into plastic. (Do Not Use Red Loctite)



### Black Graphite Grease

Lubricate all gears before assembly. Apply grease to the places shown by this mark.



Item not included.



### Siliking Grease

Lubricate all moving parts including joints and bearings. Apply grease to the places shown by this mark. Apply grease first, then assemble.



### Shock Oil

Apply shock oil to the places shown by this mark.



Pay attention to note on page.



DEDICATED TO ALL OF YOU WHO HAVE HELPED US BRING THIS AWESOME  
CHASSIS FROM IMAGINATION INTO REALITY.

ENJOY BEING A BADASS.

# PARTS REFERENCE

Parts Location Map

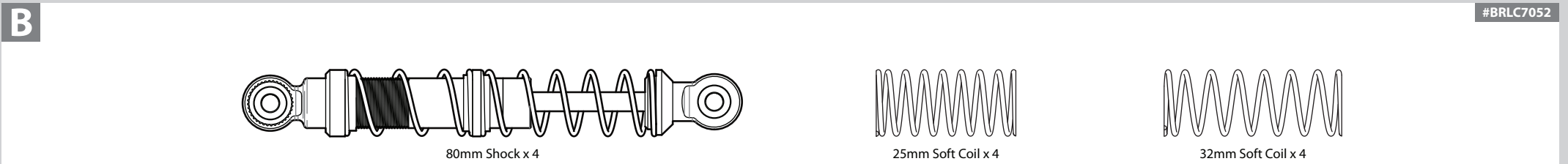
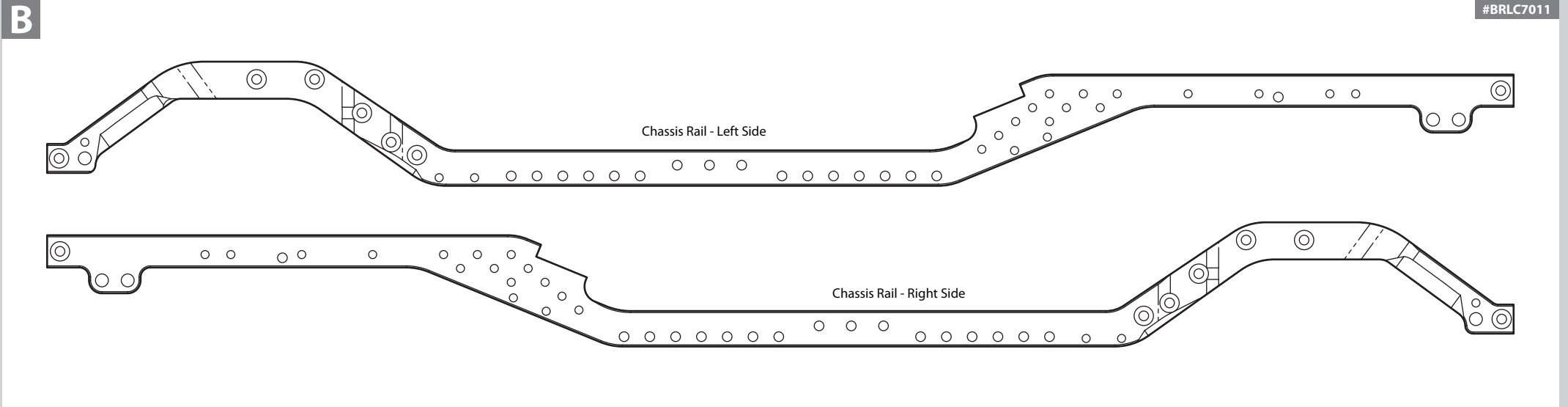
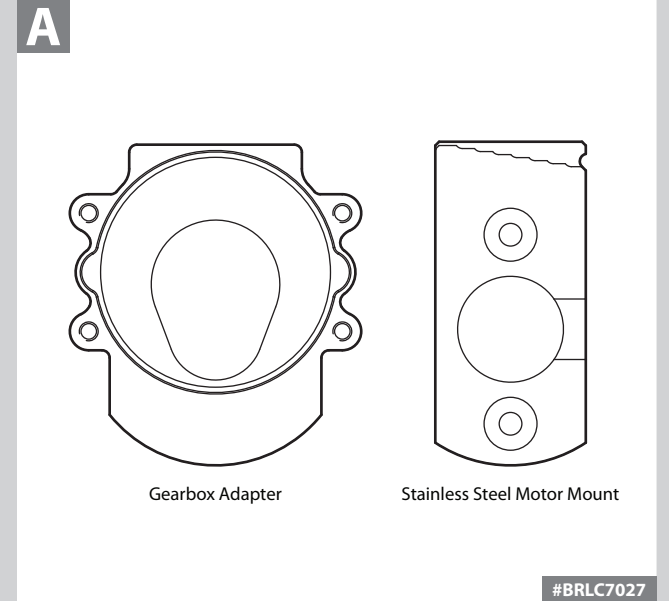
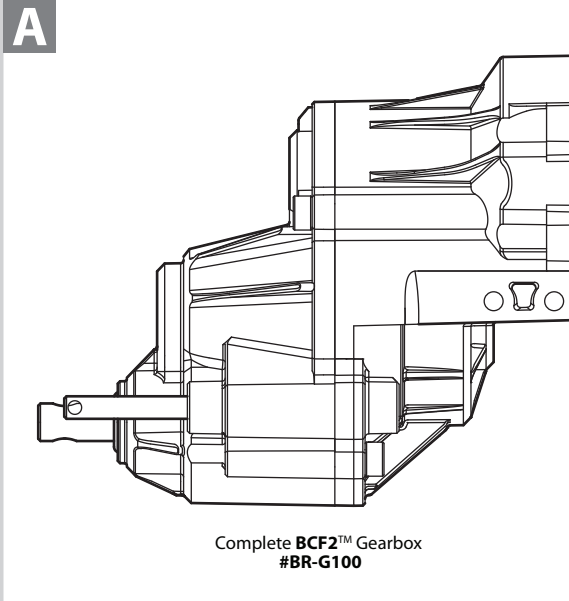
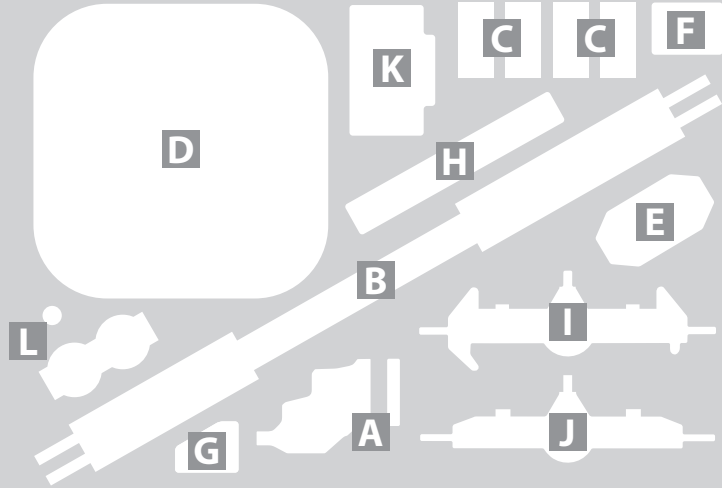

**C**

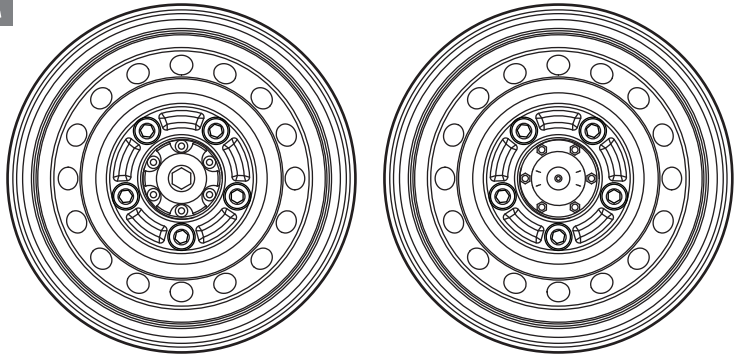

Steele Wheels (Front) x 2  
#BRW780955FGM

Steele Wheels (Rear) x 2  
#BRW780955RGM

**D**

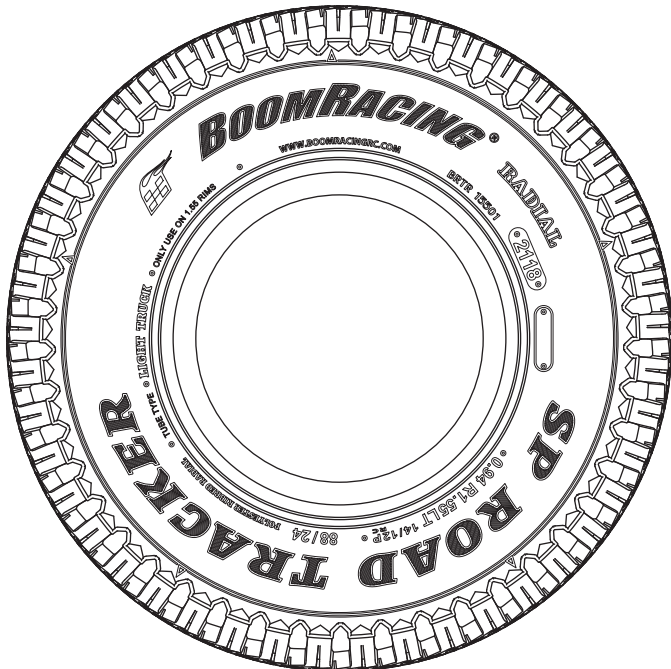

1.55 SP ROAD TRACKER™ Crawler Tire GEKKO Compound  
3.46x0.94 Inch (88x24mm) w/ Single Stage Open Cell Foam x 4  
#BRTR15501

**D**

**9 ACCESSORIES**

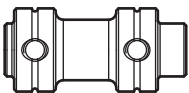

Connection Shaft  
#BRLC7028

12T 32P Pinion Gear  
#BRPG3212-3

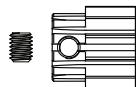

**D 1 CHASSIS**

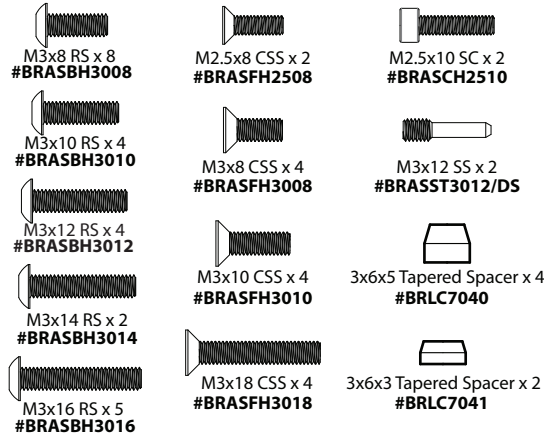

M3x8 RS x 8  
#BRASBH3008

M3x10 RS x 4  
#BRASBH3010

M3x12 RS x 4  
#BRASBH3012

M3x14 RS x 2  
#BRASBH3014

M3x16 RS x 5  
#BRASBH3016

M2.5x8 CSS x 2  
#BRASFH2508

M3x8 CSS x 4  
#BRASFH3008

M3x10 CSS x 4  
#BRASFH3010

M3x18 CSS x 4  
#BRASFH3018

M2.5x10 SC x 2  
#BRASCH2510

M3x12 SS x 2  
#BRASST3012/DS

3x6x5 Tapered Spacer x 4  
#BRLC7040

3x6x3 Tapered Spacer x 2  
#BRLC7041

**D 3 LINKS / SHOCKS**

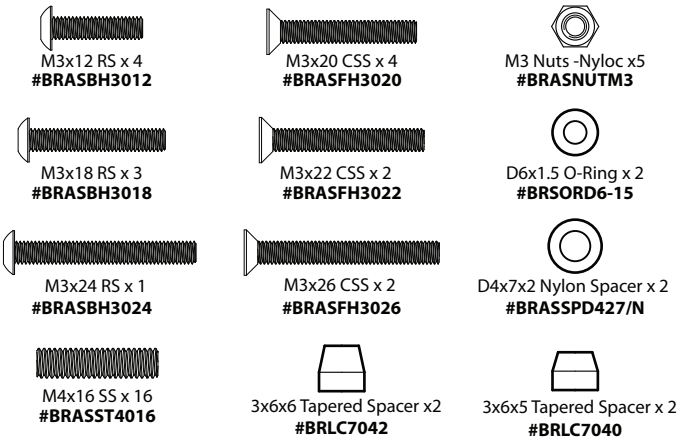

M3x12 RS x 4  
#BRASBH3012

M3x18 RS x 3  
#BRASBH3018

M3x24 RS x 1  
#BRASBH3024

M4x16 SS x 16  
#BRASST4016

M3x20 CSS x 4  
#BRASFH3020

M3x22 CSS x 2  
#BRASFH3022

M3x26 CSS x 2  
#BRASFH3026

3x6x6 Tapered Spacer x 2  
#BRLC7042

M3 Nuts -Nylco x5  
#BRASNUTM3

D6x1.5 O-Ring x 2  
#BRORD6-15

D4x7x2 Nylon Spacer x 2  
#BRASSPD427/N

3x6x5 Tapered Spacer x 2  
#BRLC7040

**D 5 FINE TUNE SPACERS**



D4x7x1 Nylon Spacer x 2  
#BRASSPD471/N



D5x8x0.1 Spacer x 5  
#BRASSPD5801

**D 2 GEARBOX / TRANSFER CASE**

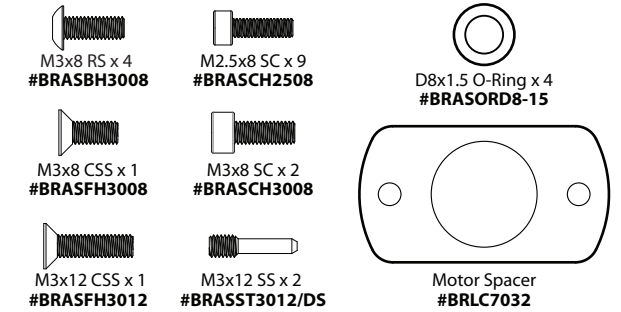

M3x8 RS x 4  
#BRASBH3008

M3x8 CSS x 1  
#BRASFH3008

M3x12 CSS x 1  
#BRASFH3012

M2.5x8 SC x 9  
#BRASCH2508

M3x8 SC x 2  
#BRASCH3008

M3x12 SS x 2  
#BRASST3012/DS

D8x1.5 O-Ring x 4  
#BRASORD8-15

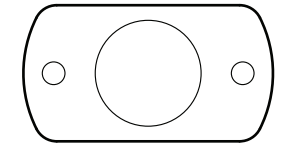

Motor Spacer  
#BRLC7032

**D 4 SERVOS**

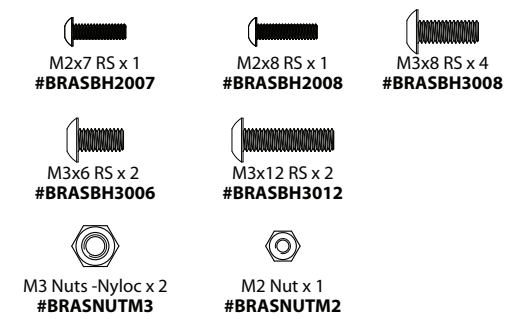

M2x7 RS x 1  
#BRASBH2007

M3x6 RS x 2  
#BRASBH3006

M3 Nuts -Nylco x 2  
#BRASNUTM3

M2 Nut x 1  
#BRASNUTM2

M2x8 RS x 1  
#BRASBH2008

M3x12 RS x 2  
#BRASBH3012

M2 Nut x 1  
#BRASNUTM2

M3x8 RS x 4  
#BRASBH3008

**D 7 BODY MOUNTS**

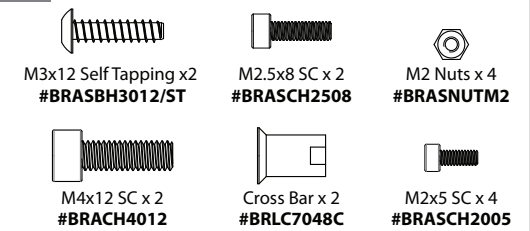

M3x12 Self Tapping x 2  
#BRASBH3012/ST

M4x12 SC x 2  
#BRACH4012

M2.5x8 SC x 2  
#BRASCH2508

Cross Bar x 2  
#BRLC7048C

M2 Nuts x 4  
#BRASNUTM2

M2x5 SC x 4  
#BRASCH2005

**D 6 RECEIVER BOX**



M3x8 RS x 4  
#BRASBH3008

M2.5x6 RS x 2  
#BRASBH2506

**D 8 WHEELS**



2x10mm Pin x 4  
#BRASPIN210

M3x3 SS x 4  
#BRASST3003

M4 Nuts - Nylco x 4  
#BRASNUTM4

Hex Adapter x 4  
#BRLC7056

**D 9 ACCESSORIES**

#BRLC7049

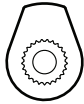

Initiator Horn A



Spring Horn A



Follower Horn A



M2x8 SC x 2  
#BRASCH2008

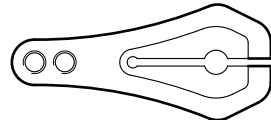

Aluminum Long Low Profile Servo Horn-25T  
#BRLC7055

**D 10 ROD ENDS**

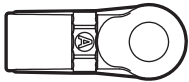

KUDU™ Nylon Rod End  
(Straight 18.5mm) x 13  
#BRW750306A

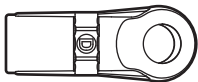

KUDU™ Nylon Rod End  
(Upwards 20mm) x 6  
#BRW750307D

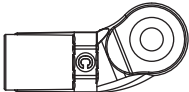

KUDU™ Nylon Rod End  
19.5mm (Sideways) x 1  
#BRW750308C



D2 Ball End x 2  
#BRQ90351



BADASS™  
Stainless Steel Pivot Ball x 20  
#BRW750310

**E**

#BRLC7018

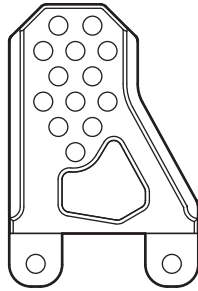

Damper Mount - Right Side

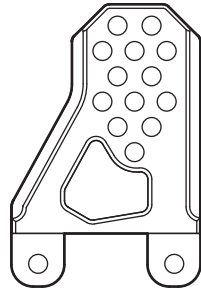

Damper Mount - Left Side

**E**

#BRLC7019

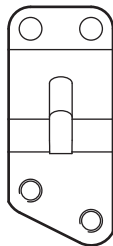

Gearbox Side Mount  
Left

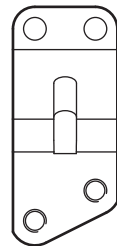

Gearbox Side Mount  
Right

**F**

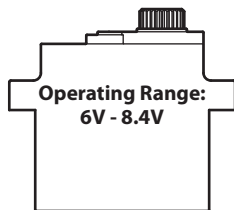

Operating Range:  
6V - 8.4V

JX Waterproof HV Mini Servo  
#JX/PDI-HV1151MG

**E**



Gearbox End Mount  
#BRLC7008

**D**

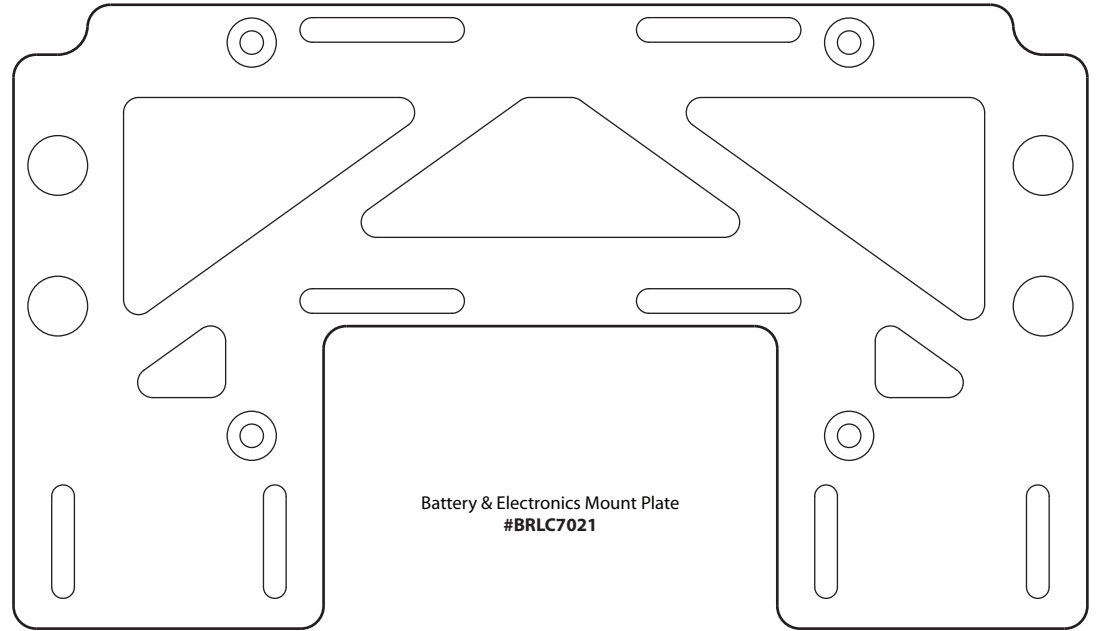

Battery & Electronics Mount Plate  
#BRLC7021

**D**



Steering Servo Mount  
#BRLC7016

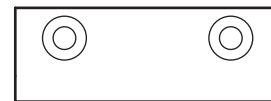

Body Hinge Mount  
#BRLC7013

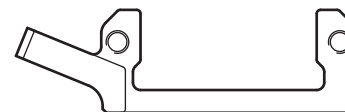

2 Speed Servo Mount  
#BRLC7009

**D**

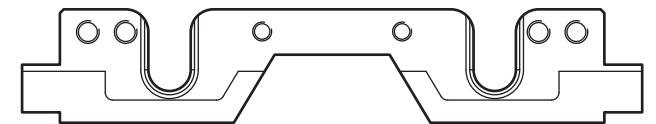

Front Crossmember  
#BRLC7015

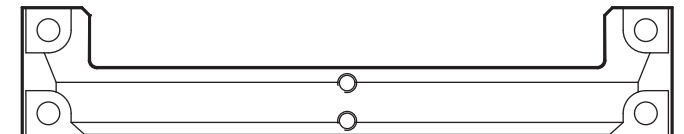

Middle Crossmember  
#BRLC7014



Rear Crossmember  
#BRLC7012

**E**

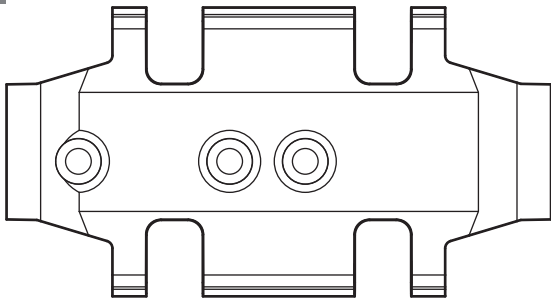

High Clearance Skid Plate  
#BRLC7020

**G**

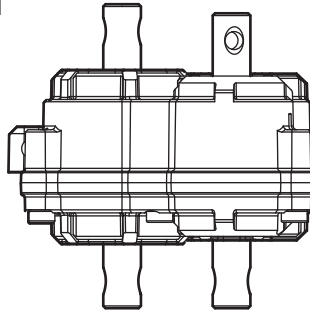

Complete **B2X™** Anti-Torque Twist Transfer Case Kit  
#BRX02374

**H**

#BRLC7034



Link - 63mm x 1



Link - 70mm x 2



Link - 93mm x 2



Link - 114mm x 2

**H**

#BRLC7043

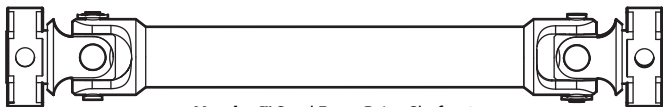

**Voodoo™** Steel Front Drive Shaft x 1



M3/2.5x12 Set Screw x 4  
#BRASST3012/DS



D5x7x2.7 Spacer x 4  
#BRASSPD5727



**Voodoo™** Steel Rear Drive Shaft x 1

Rebuild Kit Available  
#BRQ90279KIT

**H**

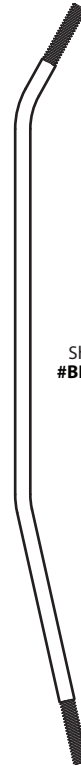

Shift Rod  
#BRLC7051



Counter Threaded Link  
55mm x 2  
#BRLC7050



Tie Rod  
#BRLC7003

**I**

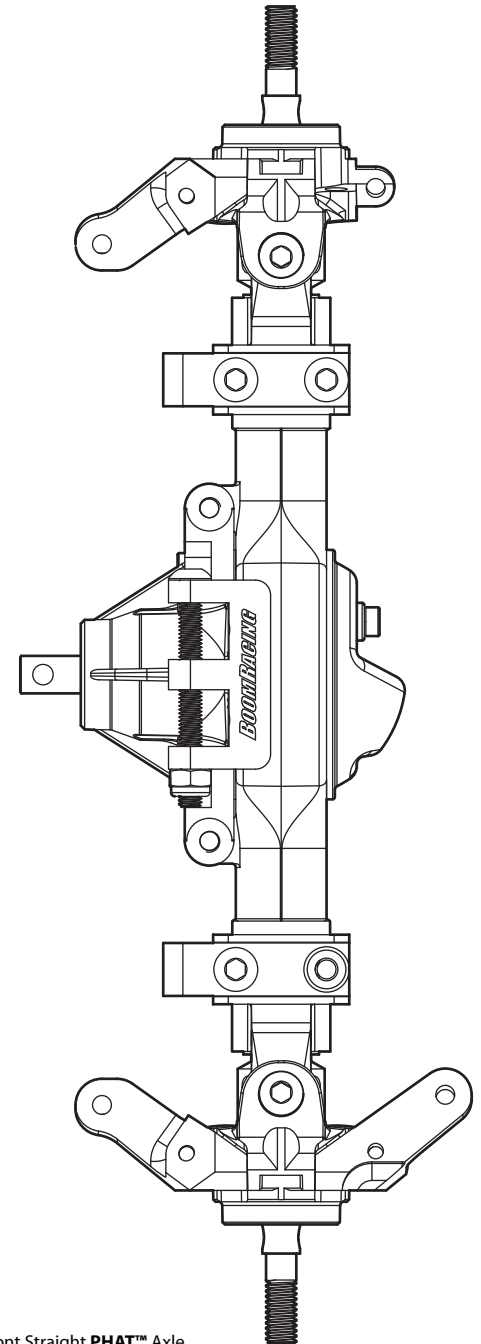

BRX70 Front Straight **PHAT™** Axle  
(Center Pumpkin) w/ AR44 HD Gears for BRX01 Assembled  
#BRLC7057

K

#BRLC7033



Stainless Steel Sealing Cap

#BRLC7033A

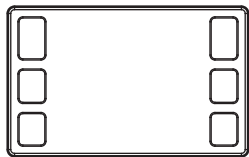

Silicone Port

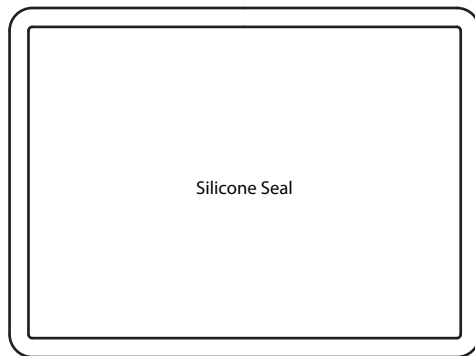

Silicone Seal

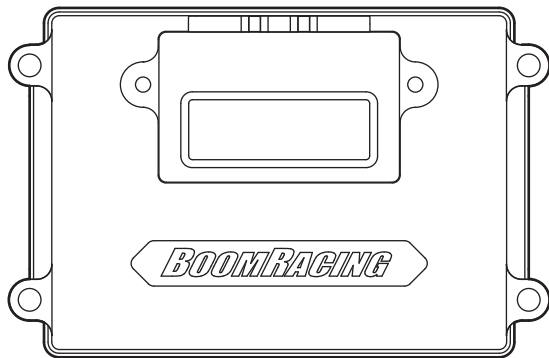

Receiver Box Lid

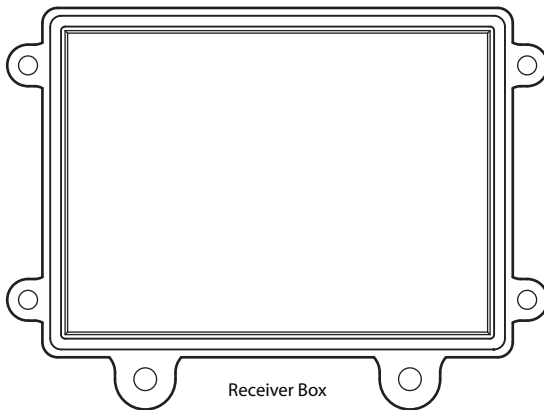

Receiver Box

K

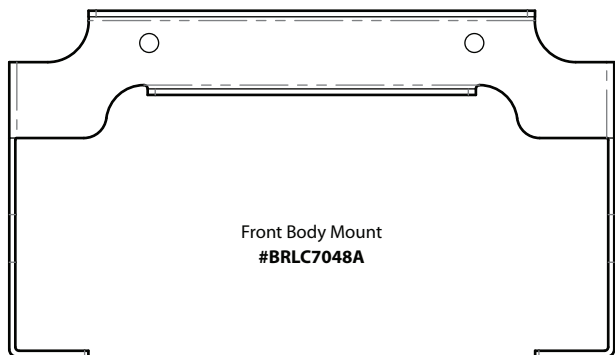

Front Body Mount  
#BRLC7048A

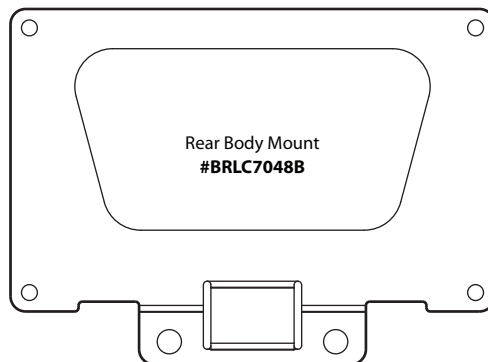

Rear Body Mount  
#BRLC7048B

J

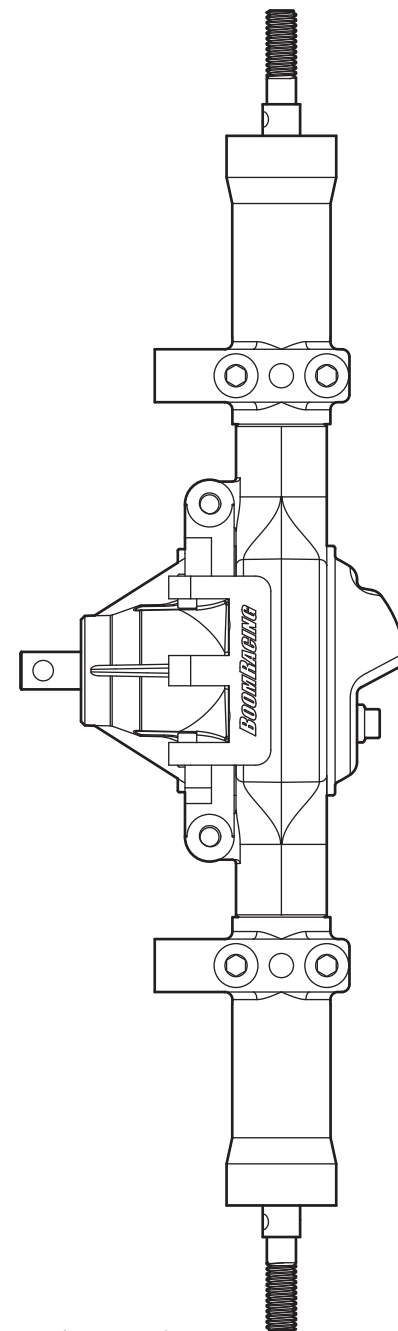

BRX70 Rear Straight PHAT™ Axle  
(Center Pumpkin) w/ Reversed AR44 HD Gears for BRX01 Assembled  
#BRLC7058

D

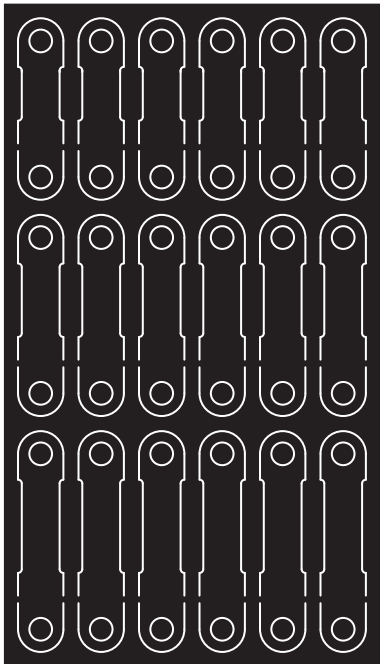

Cable Wiring Retainer  
18 pieces / Use M2.5 or M3 Round Head Bolts  
#BRT10037

B



Battery Strap x 2 #BRGRS10

D

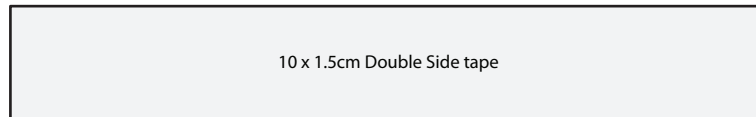

10 x 1.5cm Double Side tape

F



Extension Cable x 2  
#BRLC7059

D

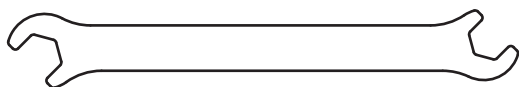

Wrench 5.5mm/5.0mm x 1

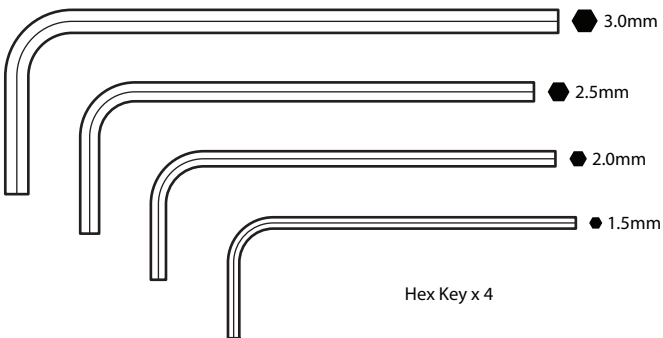

Hex Key x 4

#BRT10028

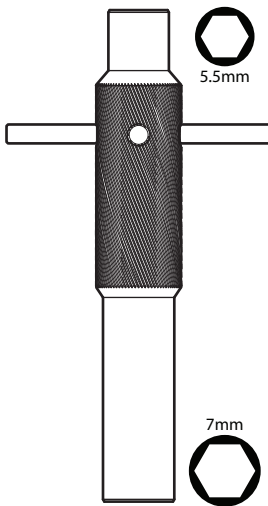

Tool - Socket x 1

L



Black Graphite Grease 10g x 1  
#BRGRS1055-10

Silicone Grease 10g x 1  
#BRGRS10274-10

242 Thread Lock 2g  
(Available separately in 10g)  
#BRGRS242

30WT Shock Oil 15ml  
(Available separately in 60ml)  
#BRSHK030

# 1- CHASSIS

Parts Needed:

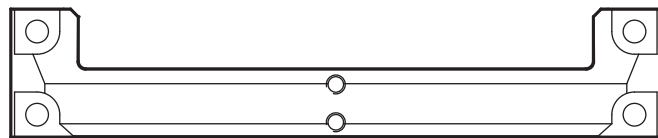
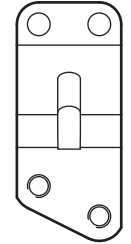
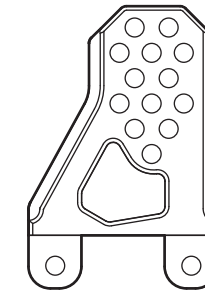
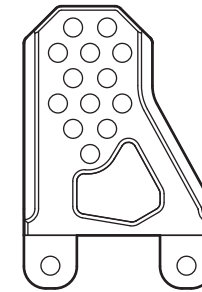
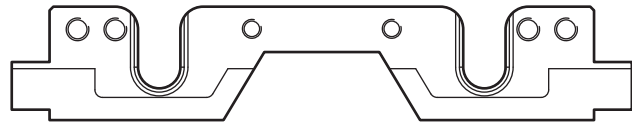
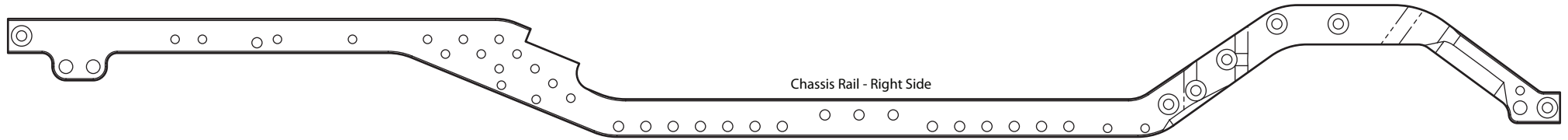
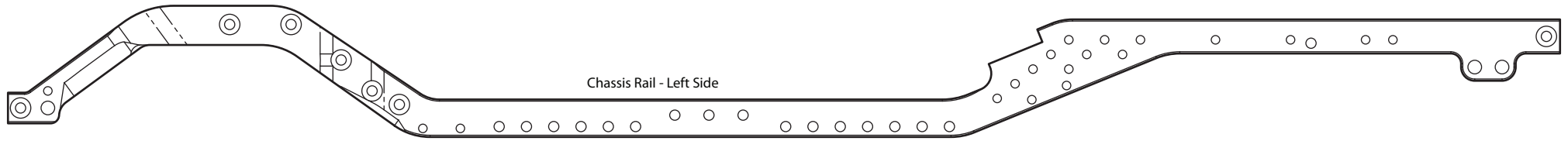

Damper Mount - Right Side

Damper Mount - Left Side

Gearbox Side Mount Left

Middle Crossmember

Body Mount Hinge

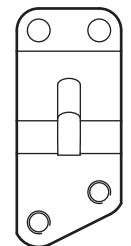
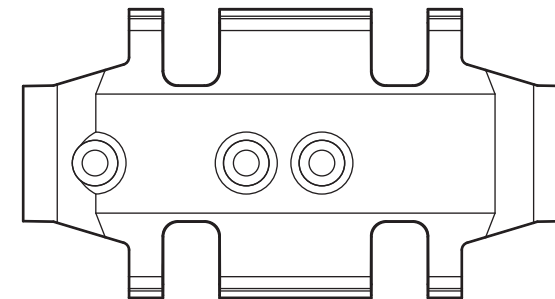
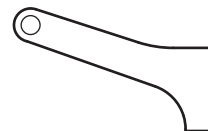
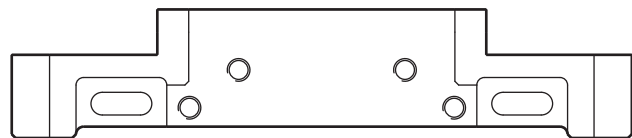

Rear Crossmember

Gearbox End Mount







High Clearance Skid Plate

Gearbox Side Mount Right

CHASSIS

CHASSIS

**1 CHASSIS**

-  M3x8 RS x 8
-  M2.5x8 CSS x 2
-  M3x10 RS x 2
-  M3x8 CSS x 4
-  M3x12 RS x 4
-  M3x10 CSS x 4
-  M3x14 RS x 2

**Thread Lock Required**  
Apply thread lock to all screws threading into metal. Not required for nyloc nuts or screws threading into plastic. (Do Not Use Red Loctite)

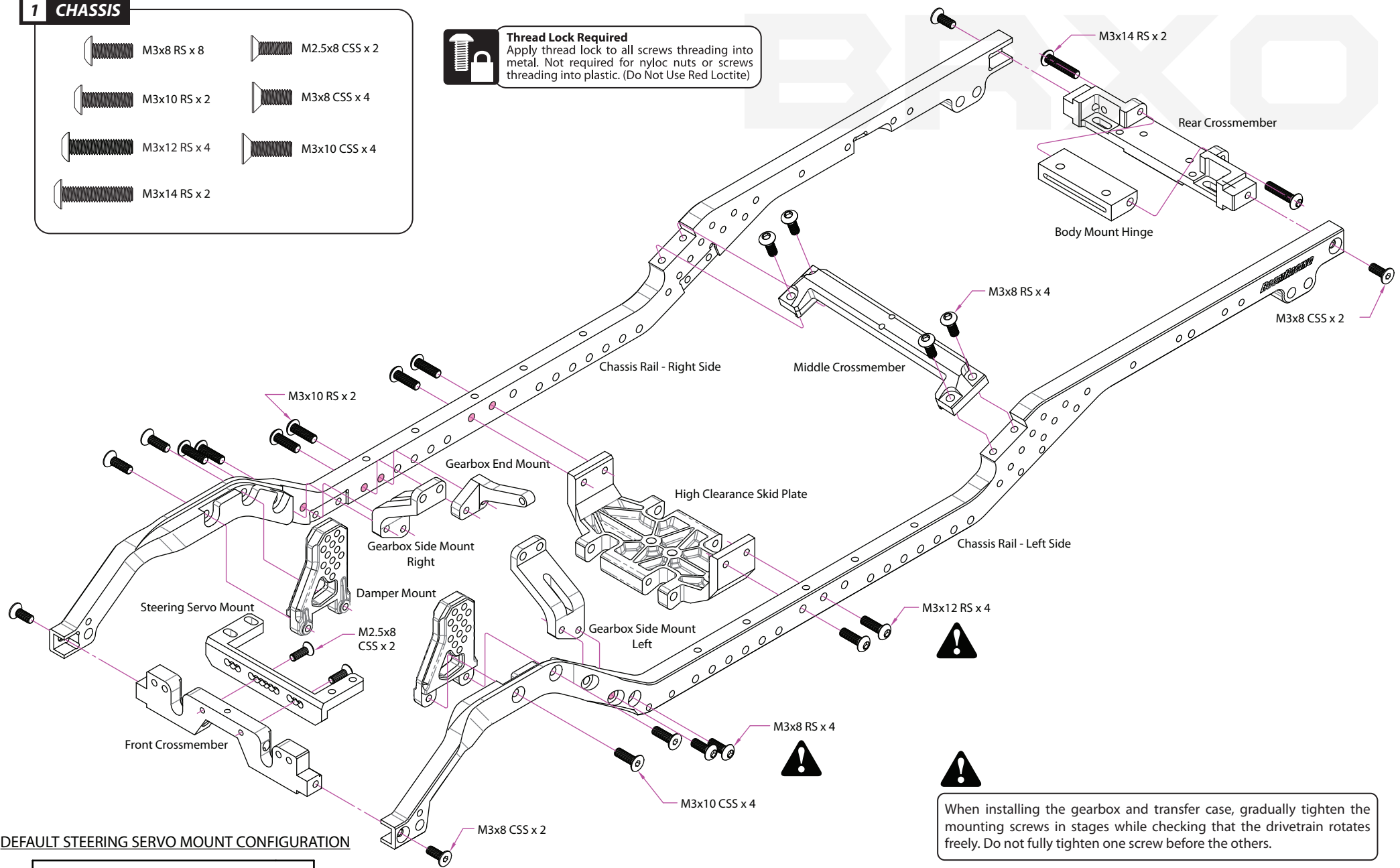

**DEFAULT STEERING SERVO MOUNT CONFIGURATION**

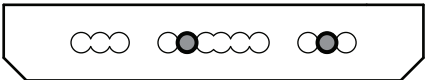

When installing the gearbox and transfer case, gradually tighten the mounting screws in stages while checking that the drivetrain rotates freely. Do not fully tighten one screw before the others.

CHASSIS

CHASSIS

# 2 - TRANSMISSION

Parts Needed:

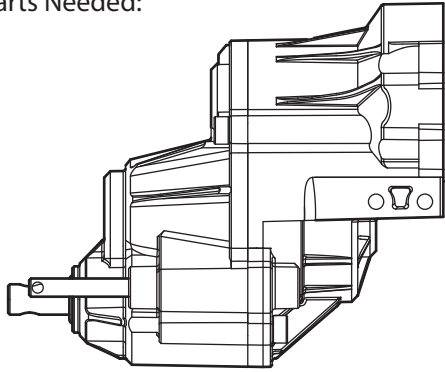

Complete **BCF2™** Gearbox  
(Exploded Diagram on Page 43)

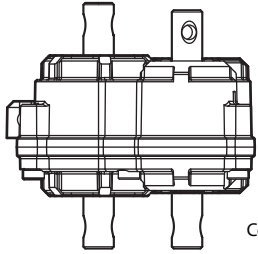

Complete **B2X™** Anti-Torque  
Twist Transfer Case Kit  
(Exploded Diagram on Page 44)

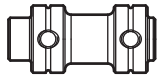

Connection Shaft

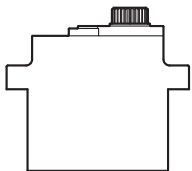

JX Waterproof HV Mini Servo  
(6V - 8.4V)



2 Speed Servo Mount

## 2.1 - TRANSMISSION

### 2 GEARBOX / TRANSFER CASE

M3x8 RS x 4

M3/2.5x12  
Set Screw x 1

D8x1.5 O-Ring x 1



Tip: Lubricate the O-ring with the supplied silicone grease before assembly and during routine maintenance to reduce friction and wear.

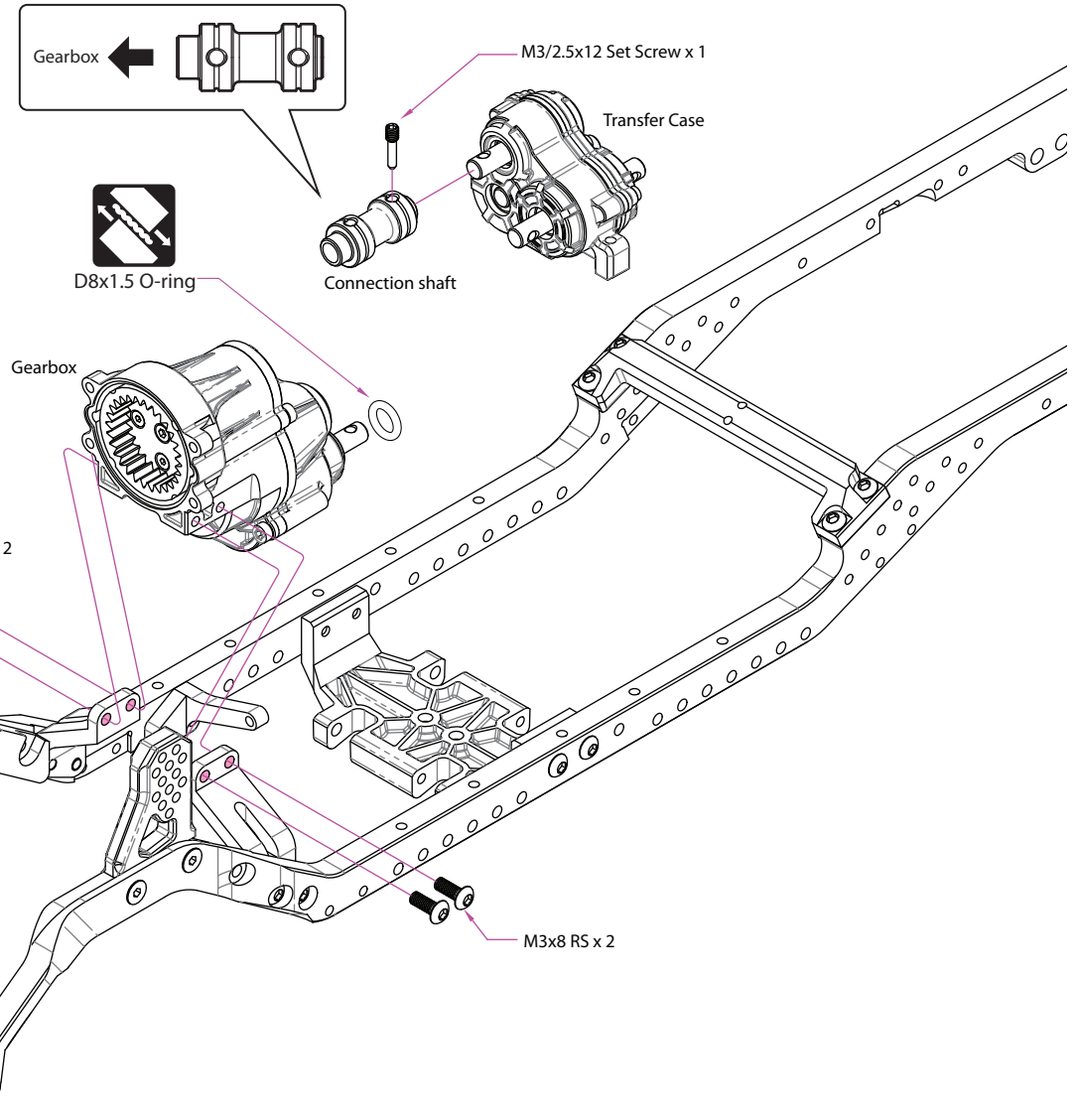

## 2.2 - TRANSMISSION

### 1 CHASSIS

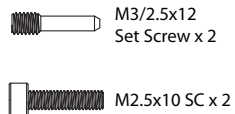

### 2 GEARBOX / TRANSFER CASE

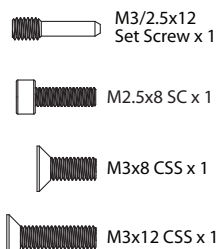

### 4 SERVOS

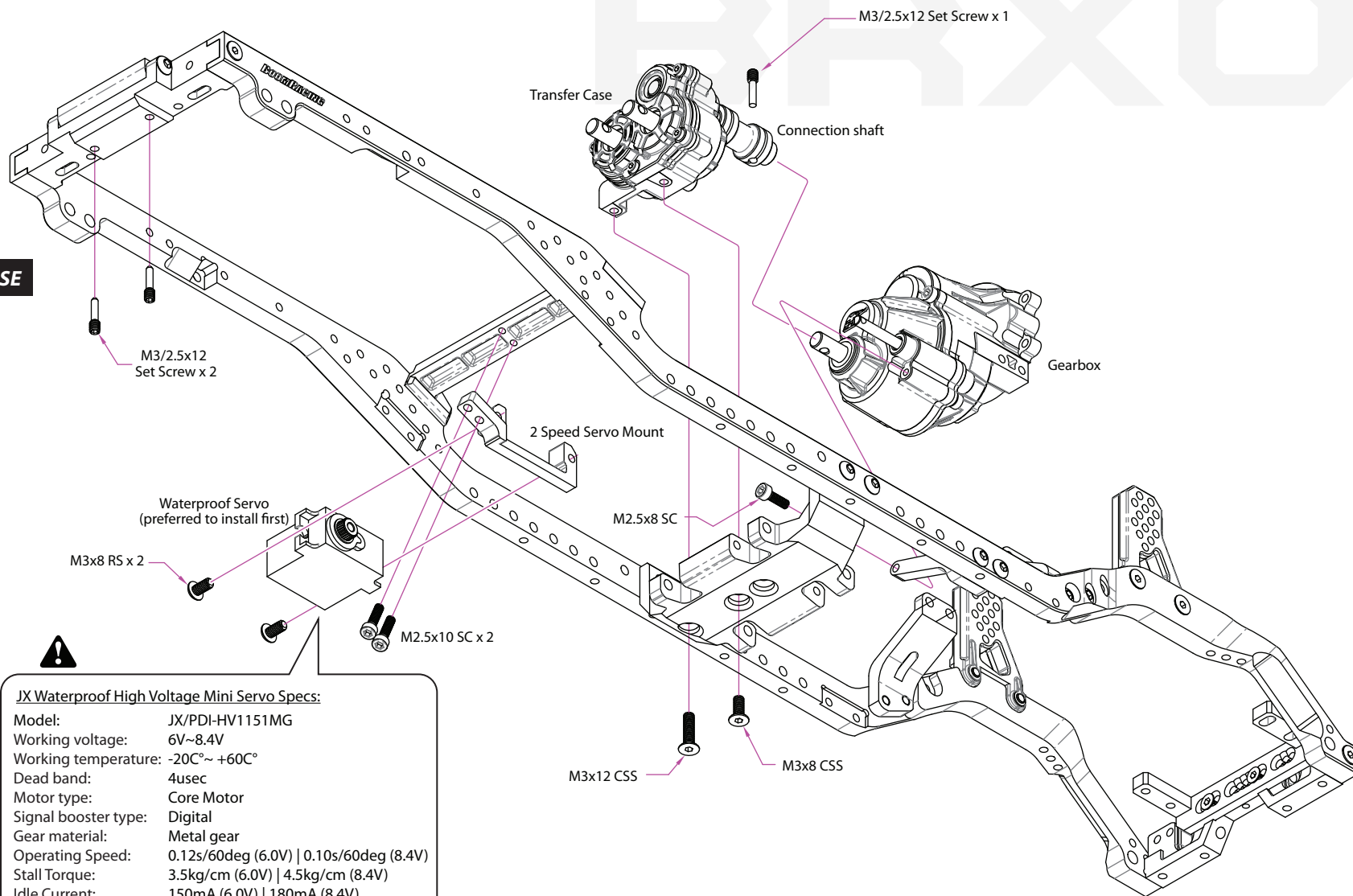

#### JX Waterproof High Voltage Mini Servo Specs:

Model:	JX/PDI-HV1151MG
Working voltage:	6V~8.4V
Working temperature:	-20°C~+60°C
Dead band:	4usec
Motor type:	Core Motor
Signal booster type:	Digital
Gear material:	Metal gear
Operating Speed:	0.12s/60deg (6.0V)   0.10s/60deg (8.4V)
Stall Torque:	3.5kg/cm (6.0V)   4.5kg/cm (8.4V)
Idle Current:	150mA (6.0V)   180mA (8.4V)
Load Current:	260mA (6.0V)   340mA (8.4V)
Size:	23.2 x 12.5 x 25.6mm
Weight:	15g
Tooth Count:	25
Wire length:	310mm JR plug
Black:	Negative
Red:	Positive
White:	Signal



#### Thread Lock Required

Apply thread lock to all screws threading into metal. Not required for nyloc nuts or screws threading into plastic. (Do Not Use Red Loctite)

# 3 - UPPER & LOWER LINKS

Parts Needed:

## 10 ROD ENDS

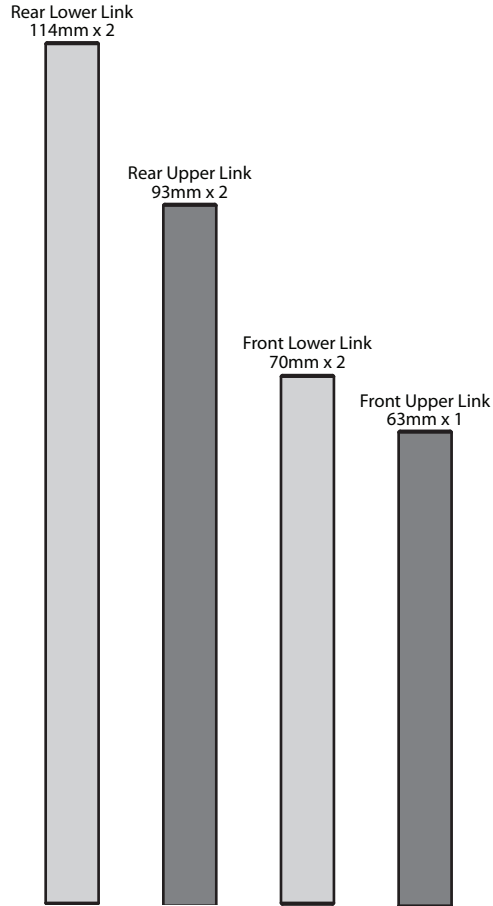
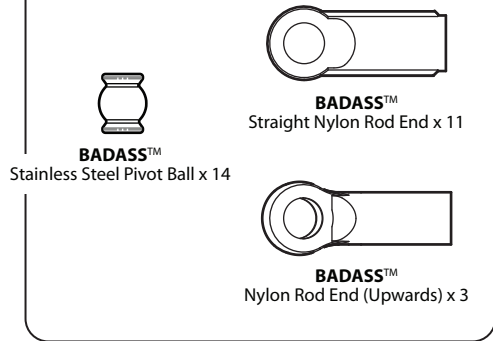

## 5 FINE TUNE SPACERS

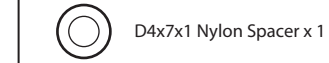

## 3 LINKS / SHOCKS

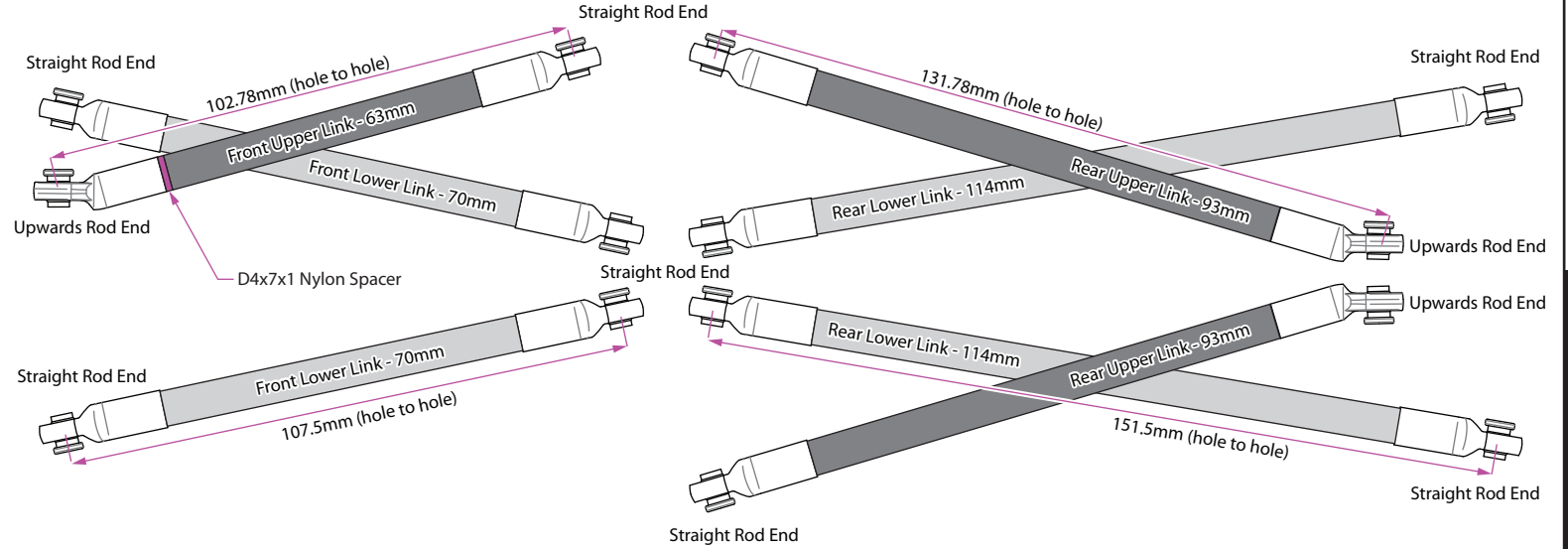

## ROD END INSTALLATION

- Install the set screw into the rod end before threading the rod end into the link.
- Repeat all remaining rod ends.
- Tip: Use a 2.0 hex driver to tighten the set screw into the rod end.

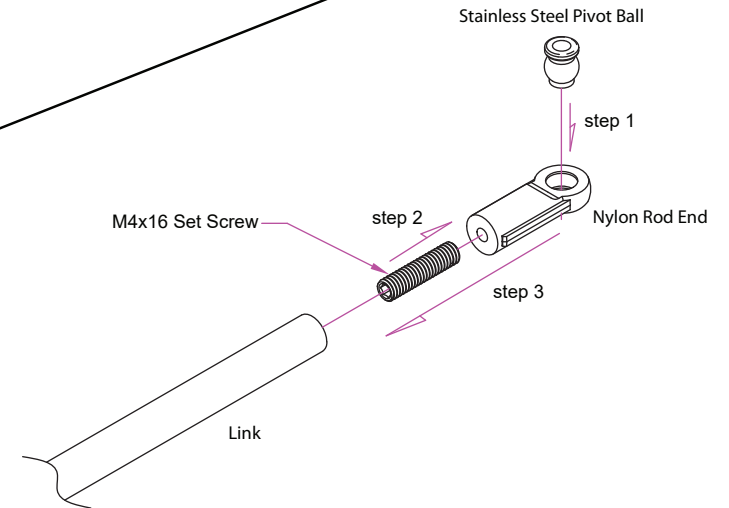

### 3.1 - UPPER LINKS

#### 3 LINKS / SHOCKS

 M3x18 RS x 3

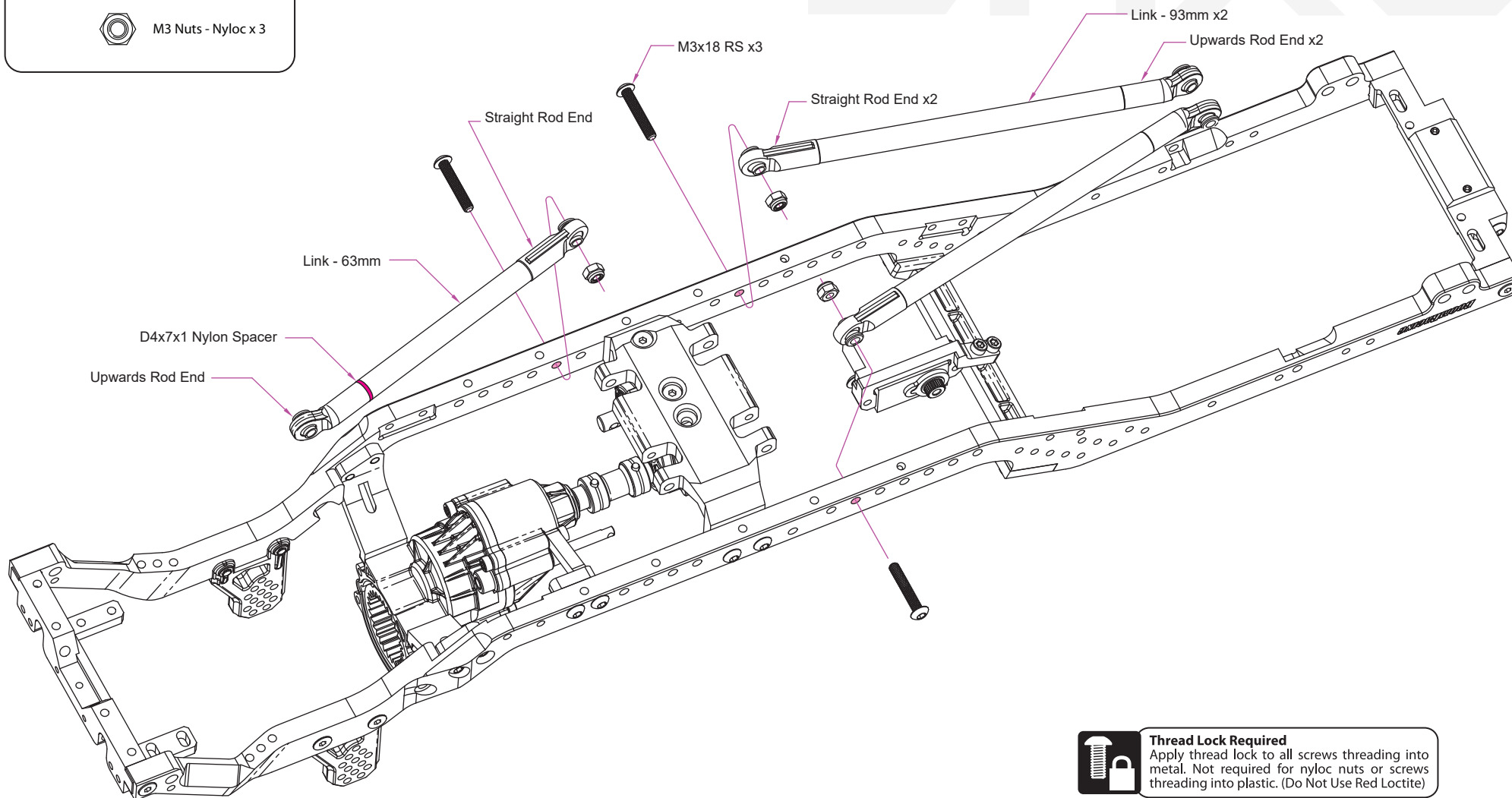
 M3 Nuts - Nyloc x 3

#### Thread Lock Required

Apply thread lock to all screws threading into metal. Not required for nyloc nuts or screws threading into plastic. (Do Not Use Red Loctite)

### 3.2 - LOWER LINKS

#### 1 CHASSIS

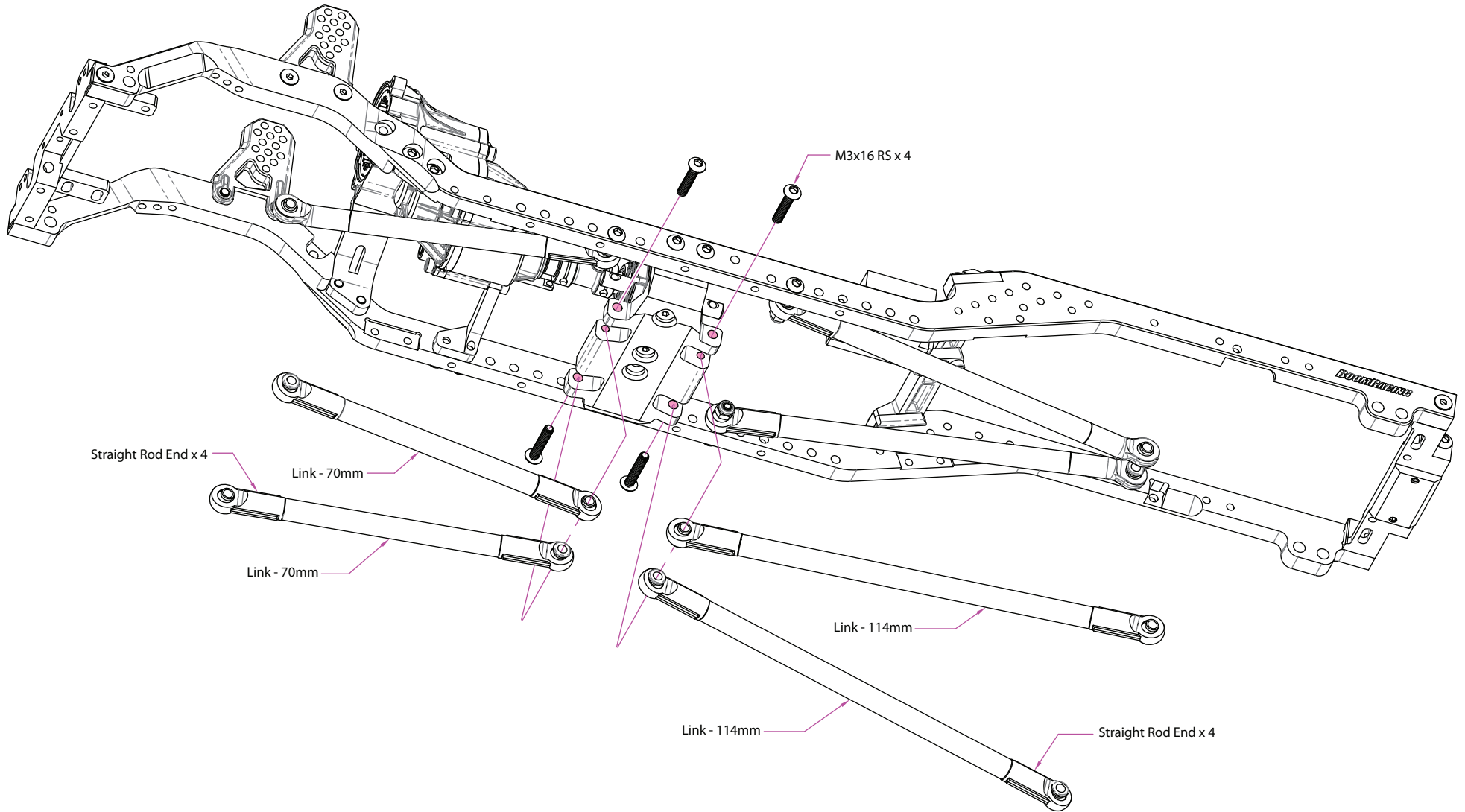
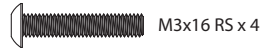

UPPER & LOWER LINKS

UPPER & LOWER LINKS

# 4 - FRONT/REAR AXLE & SHOCKS

Parts Needed:

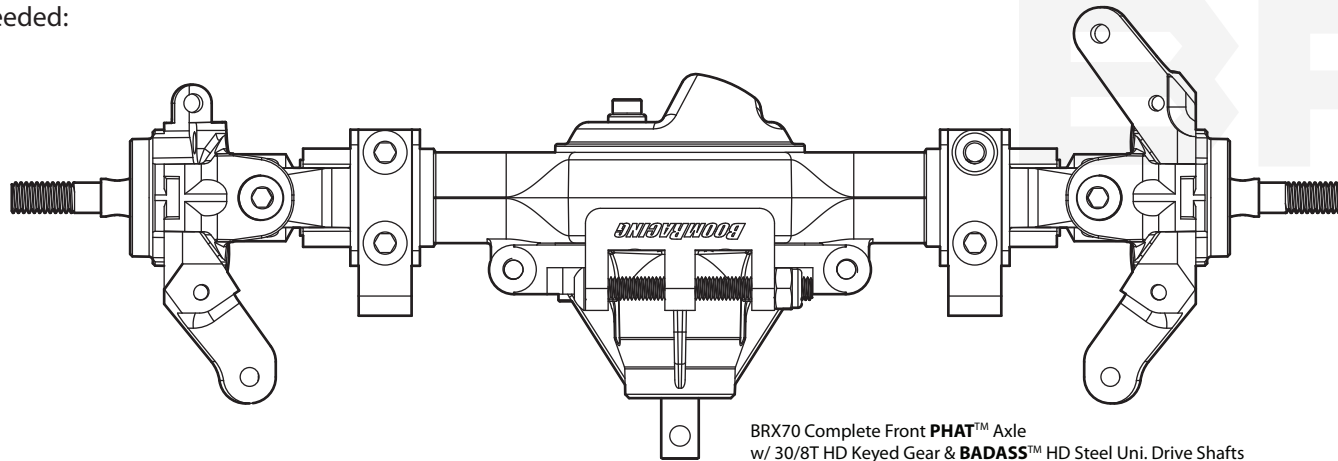

BRX70 Complete Front **PHAT™** Axle  
w/ 30/8T HD Keyed Gear & **BADASS™** HD Steel Uni. Drive Shafts  
(Exploded Diagram on Page 41)



Tie Rod



Counter Threaded Link - 55mm x 1



80mm Shock x 4

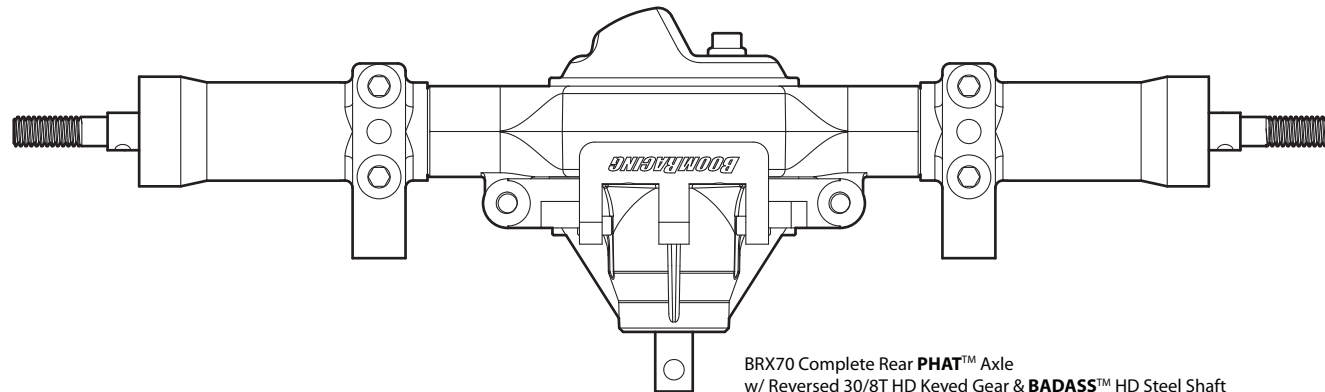

BRX70 Complete Rear **PHAT™** Axle  
w/ Reversed 30/8T HD Keyed Gear & **BADASS™** HD Steel Shaft  
(Exploded Diagram on Page 42)

## 10 ROD ENDS

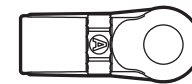

**KUDU™** Nylon Rod End  
(Straight 18.5mm) x 2

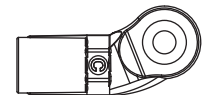

**KUDU™** Nylon Rod End  
19.5mm (Sideways) x 1

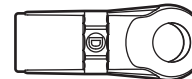

**KUDU™** Nylon Rod End  
(Upwards 20mm) x 1



**BADASS™**  
Stainless Steel Pivot Ball x 4

## PRE-ASSEMBLED FRONT AXLE

### Removing the Front Differential Cover (if the assembly is tight)

PART #BRLC7057 (Front) / #BRLC7058 (Rear)

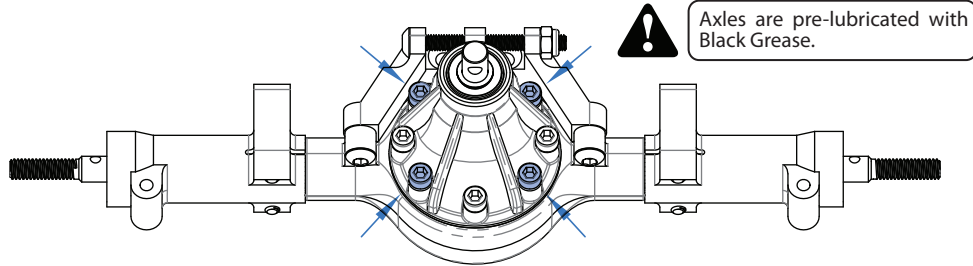

Step 1 - Loosen four M2.5x16mm socket screws indicated making the screw cap 3 mm apart from the case.

Step 2 - Using a screwdriver as a drift, lightly tap the screw heads with a small hammer to loosen the differential cover.

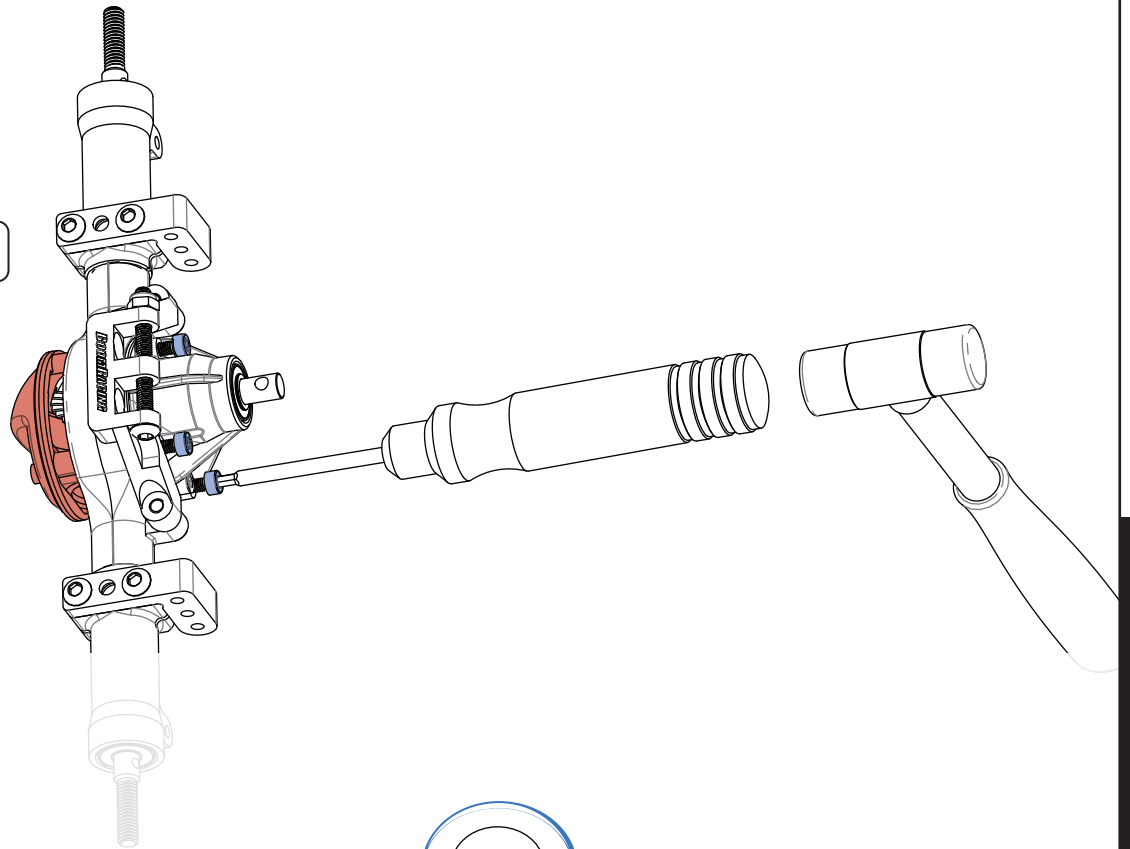

### Removing the Third Member (if the assembly is tight)

PART #BRLC7057 (Front) / #BRLC7058 (Rear)

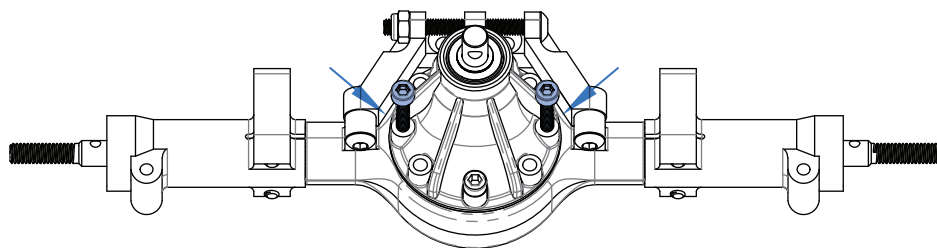

Step 1 - Remove all M2.5x16mm and two M2.5x5mm socket screws



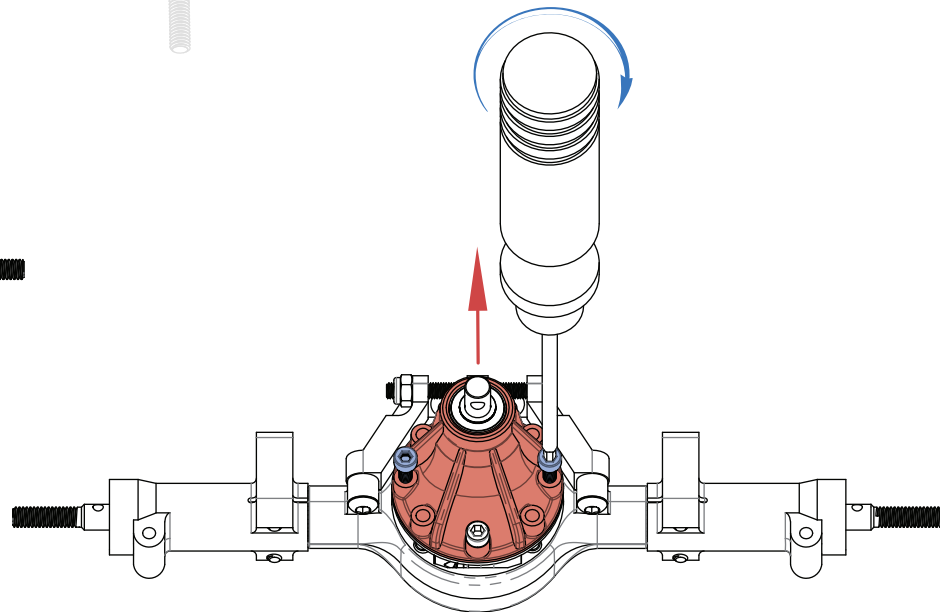

Step 2 - Install two M2.5x16mm socket screws into both left and right screw holes as indicated

Step 3 - Gradually tighten the two screws evenly until the third member is pushed free from the housing.



### 4.1 - FRONT AXLE

#### 3 LINKS / SHOCKS

-  M3x12 RS x 2
-  M3x24 RS x 1
-  M4x16 SS x 2
-  D4x7x2 Nylon Spacer x 2
-  D6x1.5 O-Ring x 2

#### 1 CHASSIS

-  3x6x3 Tapered Spacer x 1

#### PANHARD ROD

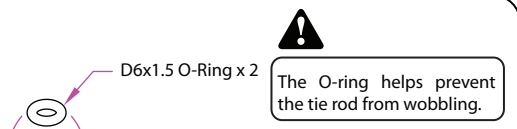
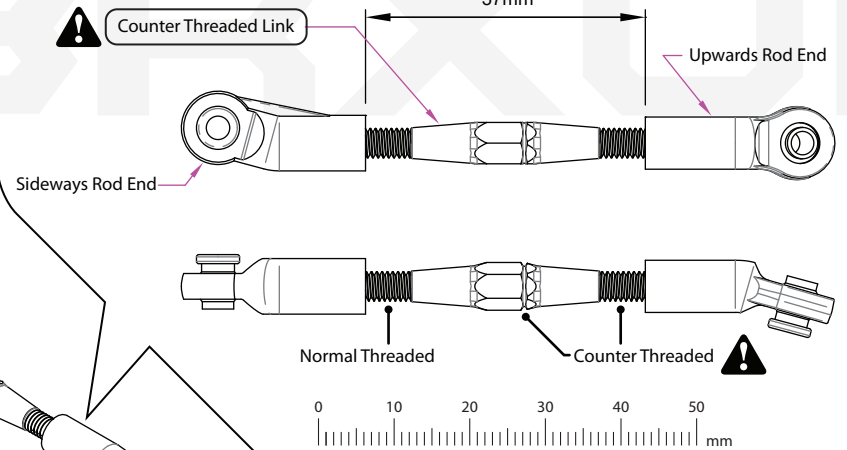

Remove this pre-installed M3 x 14 screw prior to attaching panhard rod.

Apply silking grease on the upper and lower knuckle bushing before operating the axle. Partial dissembling required - referred to Exploded Diagram on Page 41.



#### TIE ROD

M4x16 Set Screw x 2

M3x12 RS x 2

Stainless Steel Pivot Ball x 2

FRONT/REAR AXLE & SHOCKS

FRONT/REAR AXLE & SHOCKS

## 4.2 - FRONT AXLE AND SHOCKS

### 3 LINKS / SHOCKS



M3x20 CSS x 2



M3 Nuts - Nyloc x 2



M3x26 CSS x 2



D3x6x6 Tapered Spacer x 2

### SHOCKS SETUP

1

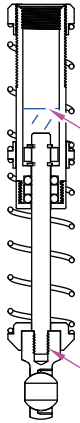

Fill the shock body approximately 1/4 to 1/2 full with the included 30WT shock oil.



**Thread Lock Required**  
Apply thread lock to all screws threading into metal. Not required for nyloc nuts or screws threading into plastic. (Do Not Use Red Loctite)

2

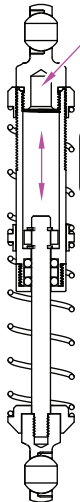

Air compression chamber

Slide piston up and down to release trapped air before closing end cap.

3



Adjust the preload collar and/or replace soft springs provided for different rebound setup.

Rebuild Kit for Shocks  
#BRLC7052-REBUILD

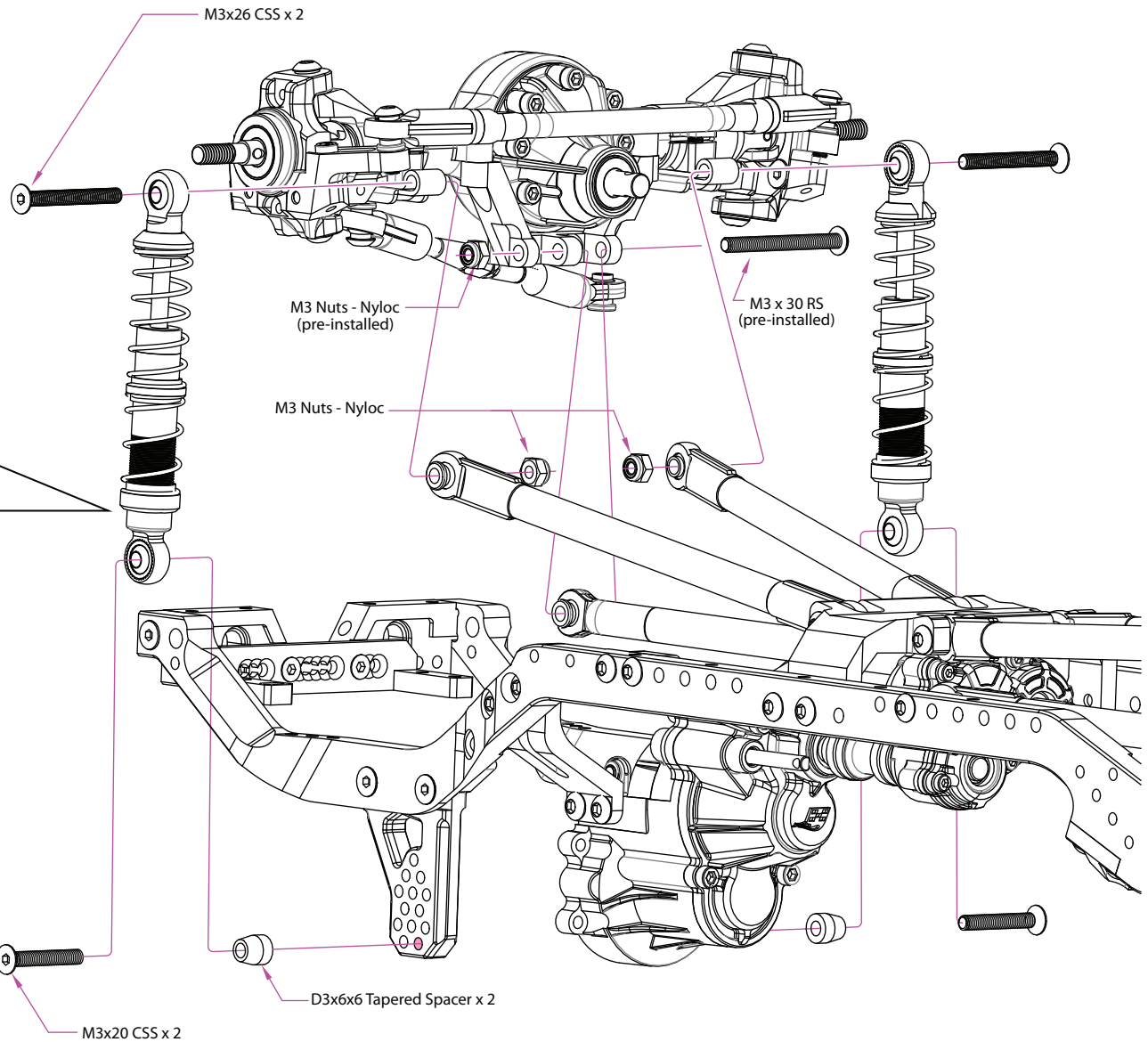

## 4.3 - PANHARD

### 1 CHASSIS

 M3x16 RS x 1

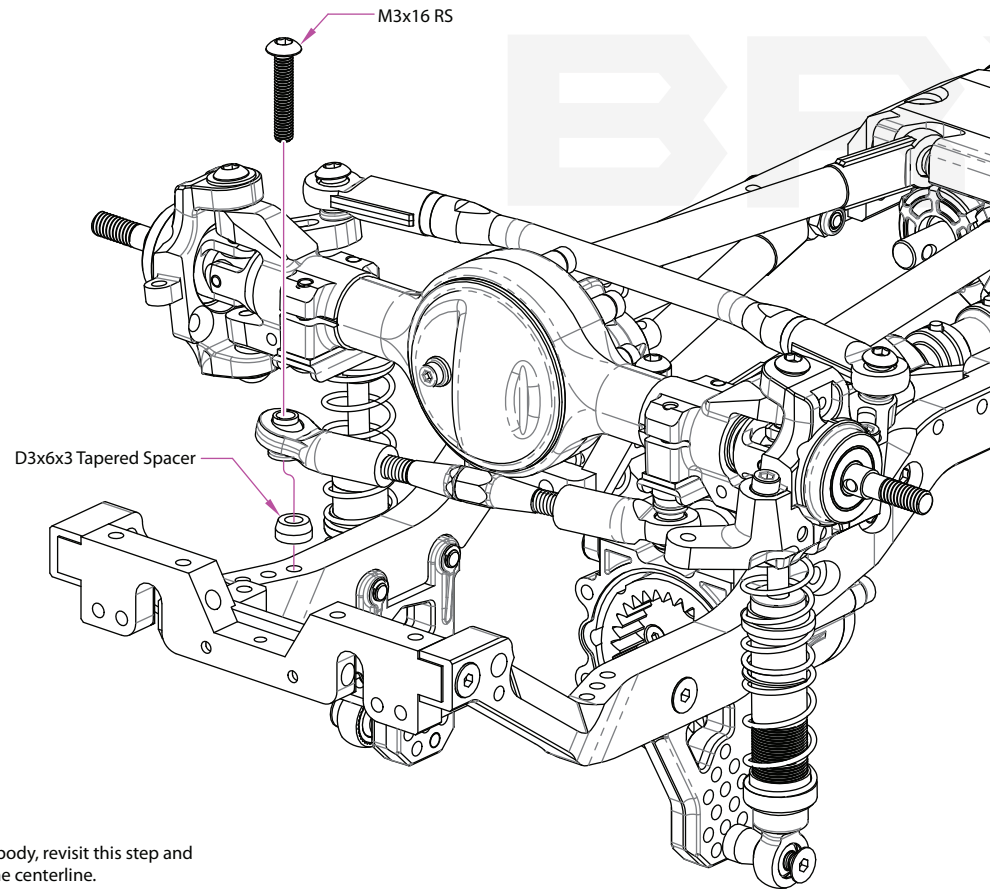
 D3x6x3  
Tapered Spacer x 1

### FRONT AXLE ALIGNMENT

After all components are installed, including electronics, battery and body, revisit this step and fine-tune the panhard bar length so that the front axle is aligned at the centerline.

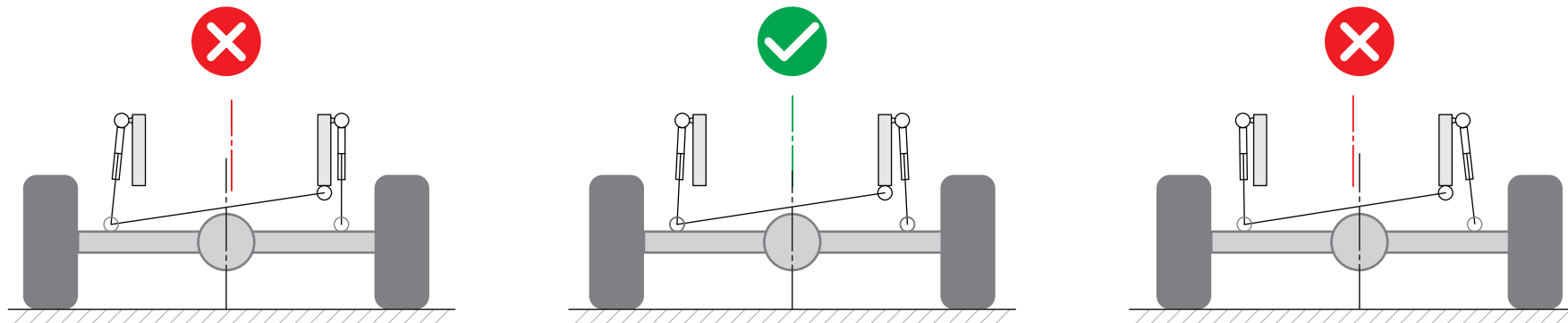

## 4.4 - REAR AXLE & SHOCKS

### 3 LINKS / SHOCKS



#### Thread Lock Required

Apply thread lock to all screws threading into metal. Not required for nyloc nuts or screws threading into plastic. (Do Not Use Red Loctite)

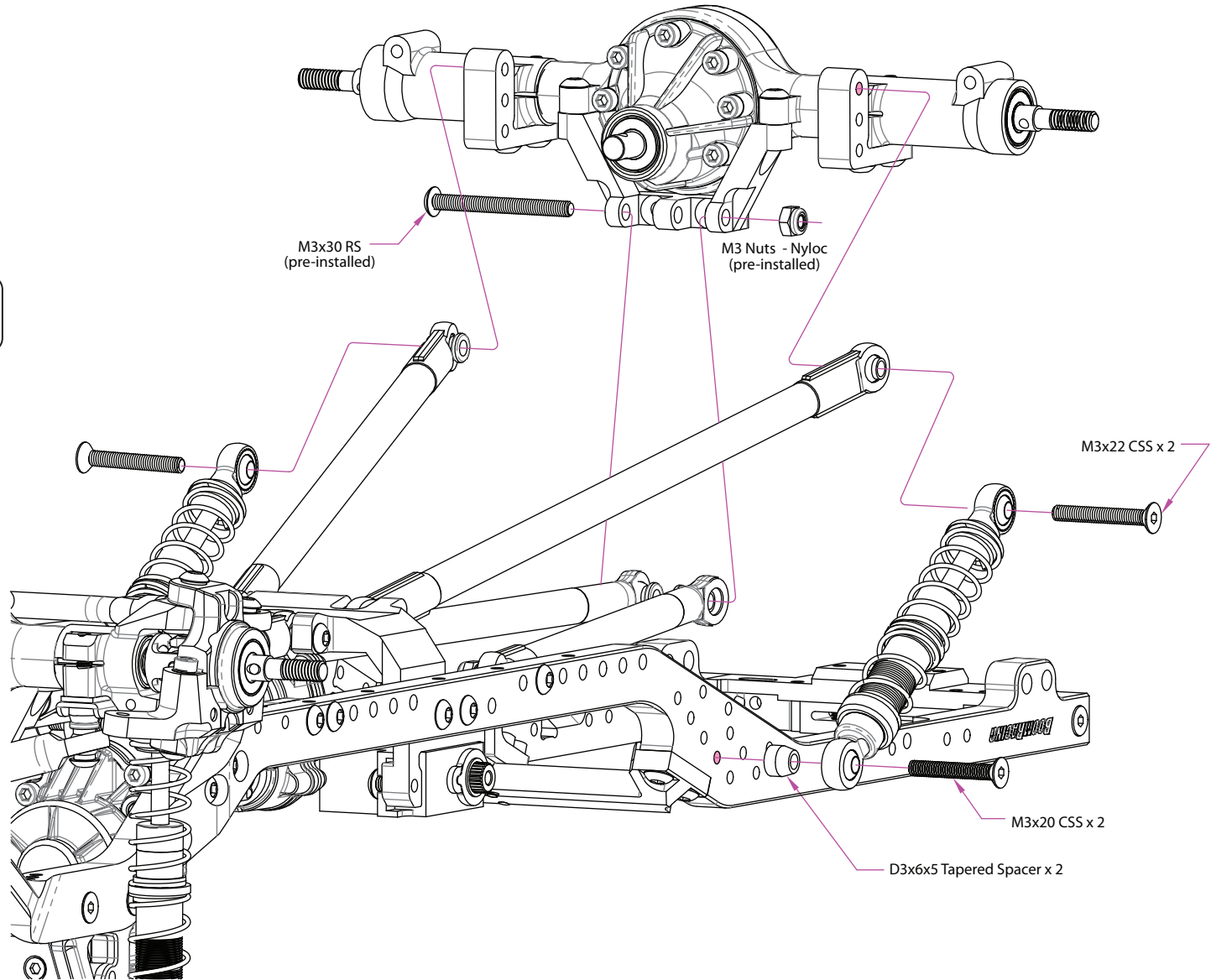

# 5 - DRIVE SHAFTS

Parts Needed:

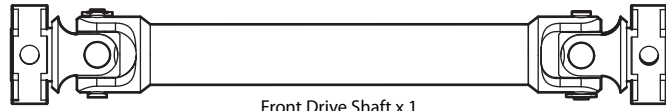

Front Drive Shaft x 1



M3/2.5x12 Set Screw x 4



D5x7x2.7 Spacer x 4

## 2 GEARBOX / TRANSFER CASE



D8x1.5 O-Ring x 2

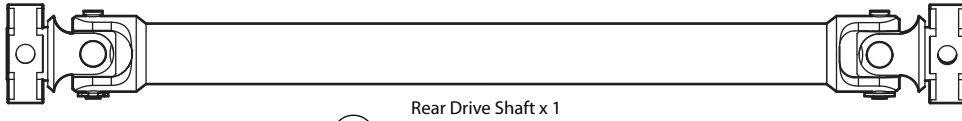

Rear Drive Shaft x 1

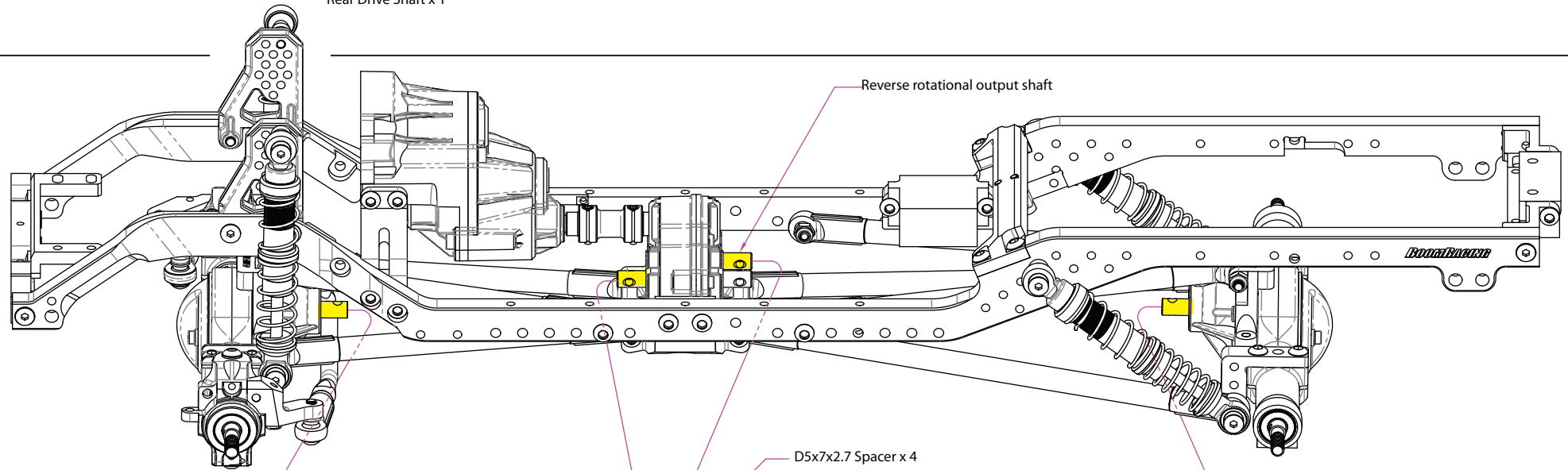

Rebuild Kit for Drive Shaft  
#BRQ90279KIT

Rebuild Kit for Drive Shaft  
#BRQ90279KIT

D5x7x2.7 Spacer x 4

M3/2.5x12 Set Screw x 4

D8x1.5 O-Ring x 2



Align the holes in the input shaft and driveshaft before installing the set screw.



**IMPORTANT:** Periodically inspect the set screws. If any become loose, remove, clean, and reapply thread lock before reassembly to prevent driveline failure.

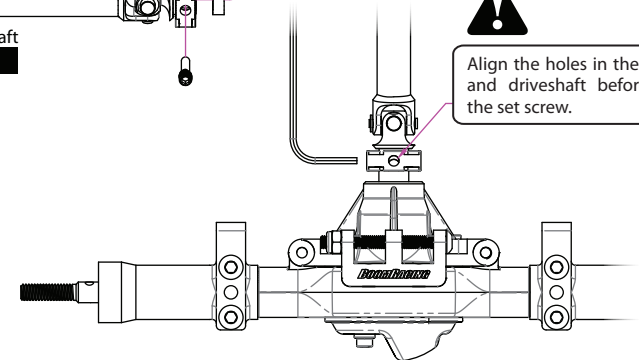

DRIVE SHAFTS

DRIVE SHAFTS

# 6 - STEERING SERVO

Parts Needed:

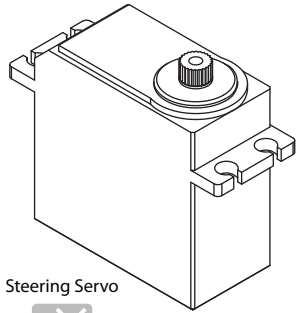

Steering Servo



## 4 SERVOS

 M3 x 8 RS x 2

 M3 x 12 RS x 2

 Nuts M3 - Nyloc x 2

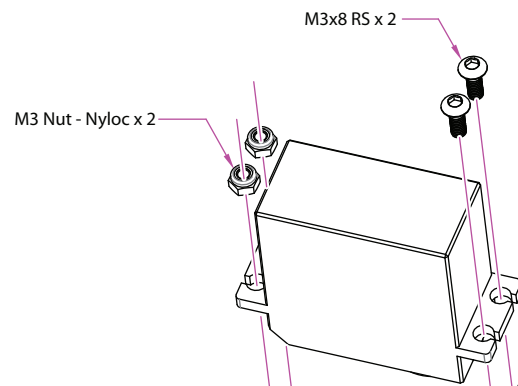

M3x8 RS x 2

M3 Nut - Nyloc x 2

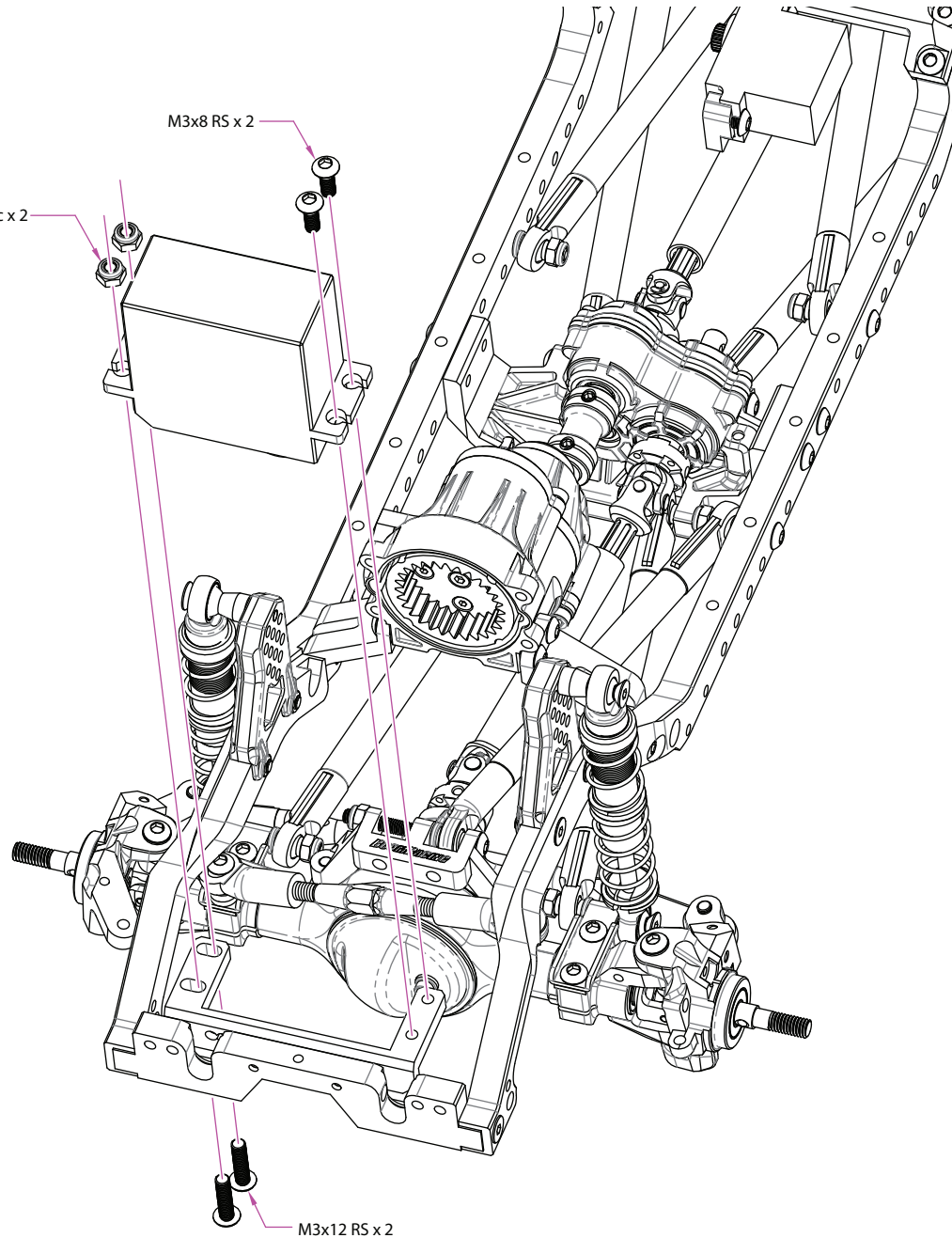

M3x12 RS x 2

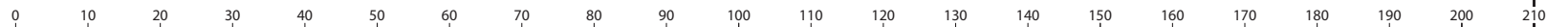

# 7- STEERING ROD

Parts Needed:



Counter Threaded Link - 55mm x 1

### 3 LINKS / SHOCKS



M3x12 RS x 2

### 4 SERVOS



M3x6 RS x 1

### 9 ACCESSORIES

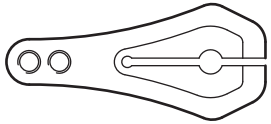

Aluminum Long Low Profile Servo Horn-25T



M2x8 SC x 2

### 10 ROD ENDS



KUDU™ Nylon Rod End (Upwards 20mm) x 2



Stainless Steel Pivot Ball x 2

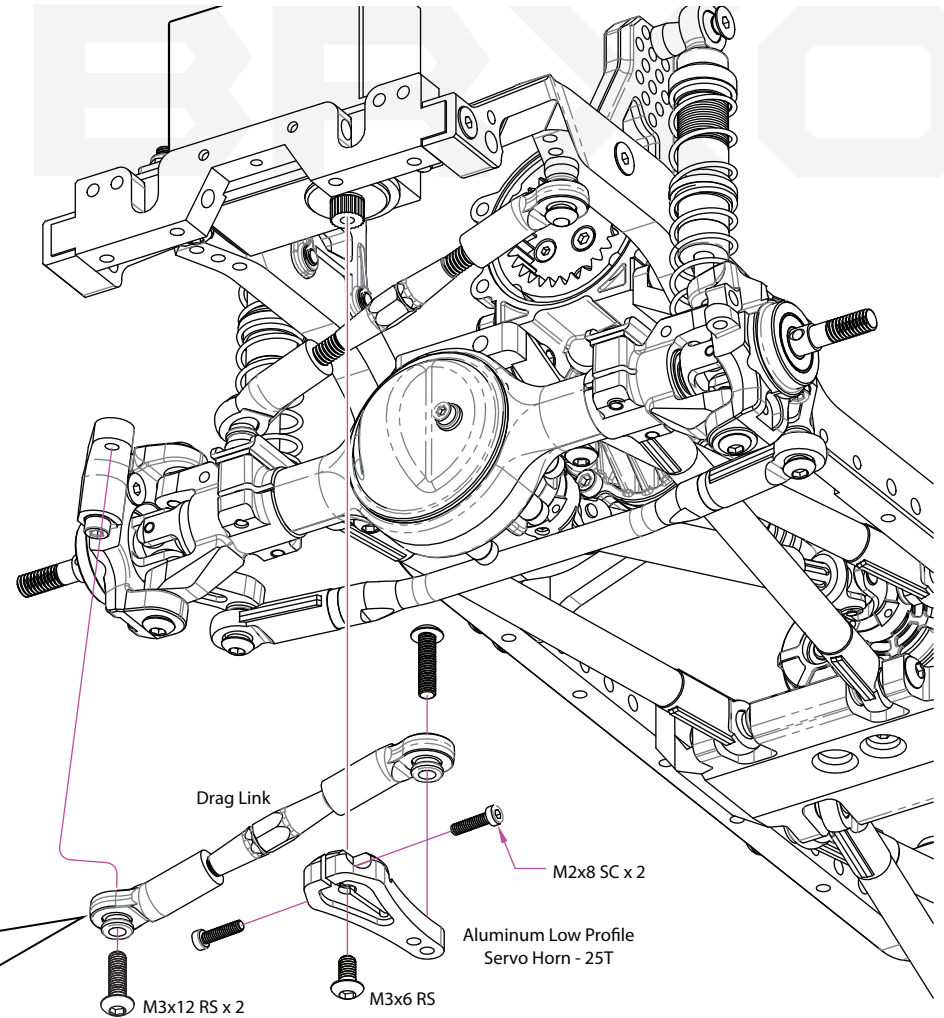

## DRAG LINK

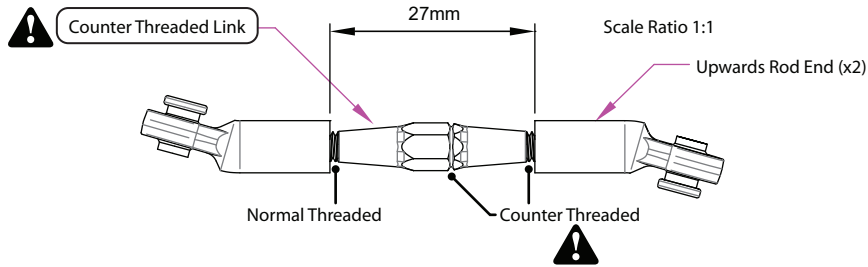

### SETTING UP THE STEERING SERVO

1. Temporarily connect the radio system before beginning setup.
2. Plug the steering servo into channel 1 and turn on electronics making sure all trims are set to zero.
3. Install the servo horn onto the servo.
4. Find the center steering position and then attach the servo horn onto the servo (if needed turn the drag link to fine tune to the center position).
5. Make sure EPA (End Point Adjustment) is adjusted to the correct throw distance to avoid servo from overloading and cause overheating.

\* Note: Failure to setup the EPA properly may cause the steering servo to get damaged and fail.

STEERING

STEERING

# 8 - GEAR SHIFTER

Parts Needed:

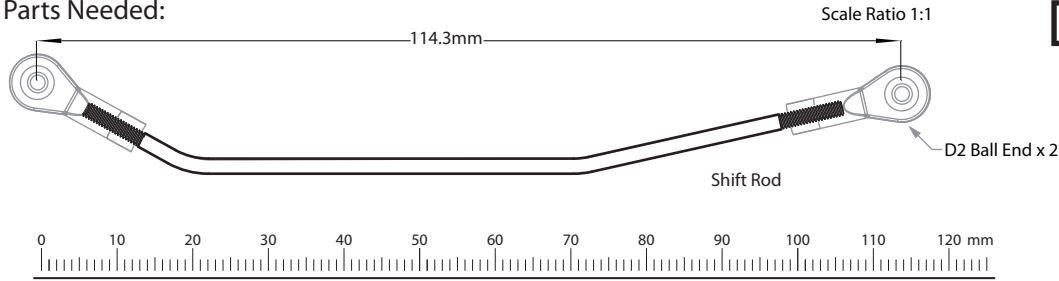

## 4 SERVOS



## 9 ACCESSORIES



## 10 ROD ENDS

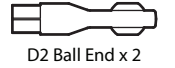

### SETTING UP THE SHIFT SERVO

1. Connect the shift rod to the gearbox shift shaft and servo saver using one M2x7 screw. Do not secure the servo saver to the servo output shaft yet.
2. Temporarily connect the radio system and assign the shift servo to a channel with 2-position switch. A 2-position switch ensures the gearbox is always fully engaged in either Low Gear or High Gear.
3. Set the EPA (End Point Adjustment) to lower values on both sides. Verify the servo rotation direction (clockwise shifts to Low Gear, counterclockwise shifts to High Gear).
4. Place the gearbox shift shaft in the Low Gear position and set the radio shift switch to Low Gear. Install the servo saver onto the servo output shaft. The shift shaft should fully extend to approximately 14.7mm in Low Gear. Rotate the driveshaft to adjust if the shaft does not fully extend. Approximately 7mm of travel is required to reach High Gear.
5. Secure the servo saver using one M3x6 screw.
6. Test the shifting operation and gradually increase EPA until both gears engage fully. Use only the minimum EPA required. Reduce EPA if the servo buzzes or binds.

\* **Important:** Failure to properly set up the servo and EPA may cause the servo to remain under constant load, resulting in premature servo failure or improper gear engagement.

Diagram 8.1

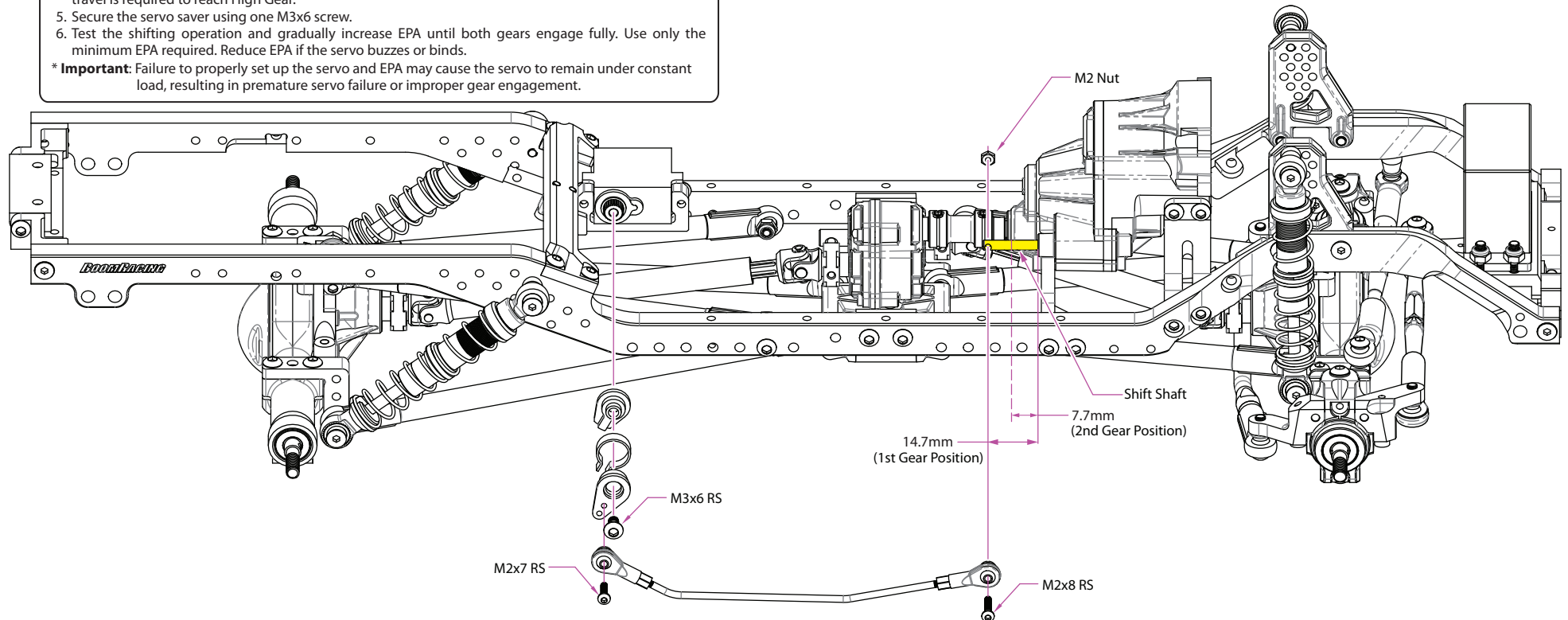
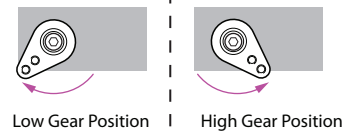

# 9 - MOTOR

## Parts Needed:

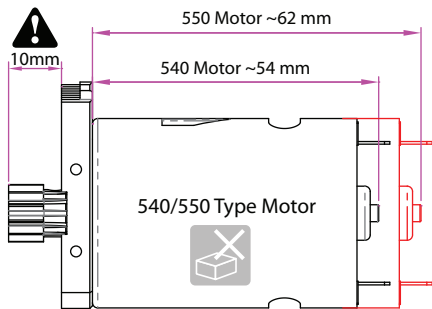

540/550 type motors can be used on BRX01.

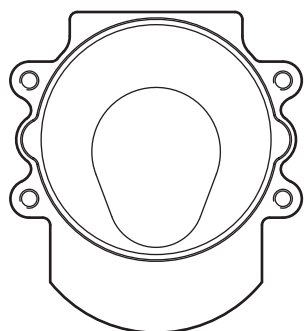

Gearbox Adapter

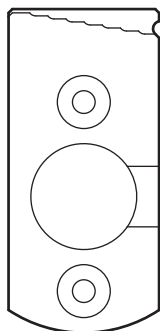

Stainless Steel Motor Mount



Use the number corresponding to the installed count pinion gear tooth on the Motor Mount to get the best gear mesh. Adjust the Motor Mount up and down until both surface indicators are leveled (align at index 12 for the 12T pinion gear supplied as pictured).

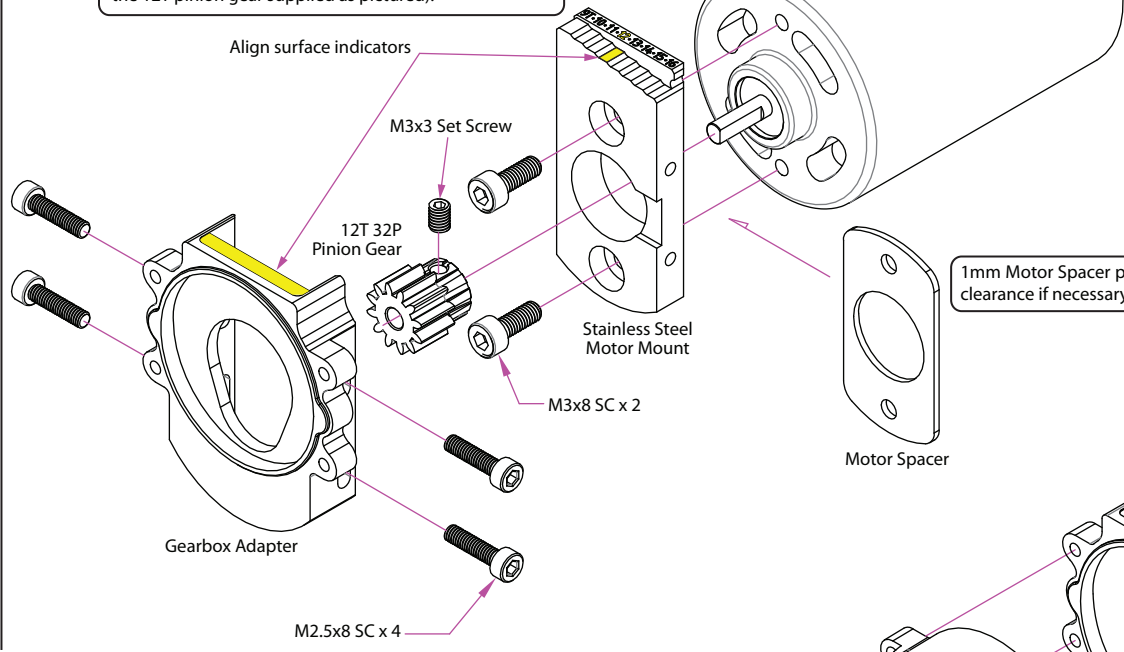

Pinion Gear	Final Drive Ratio	
	1st Gear	2nd Gear
9	60.15	27.07
10	54.13	24.36
11	49.21	22.15
12	45.11	20.30
13	41.64	18.74
14	38.67	17.40
15	36.09	16.24
16	33.83	15.23

## 2 GEARBOX / TRANSFER CASE

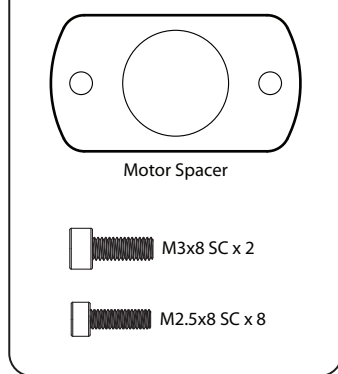

## 9 ACCESSORIES

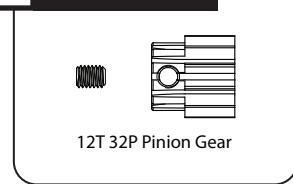

**Thread Lock Required**  
Apply thread lock to all screws threading into metal. Not required for nyloc nuts or screws threading into plastic. (Do Not Use Red Loctite)

MOTOR

MOTOR

# 10 - ACCESSORIES

Parts Needed:

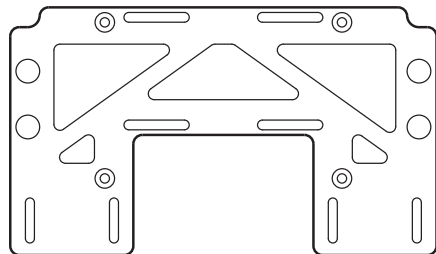

Battery & Electronics Mount Plate

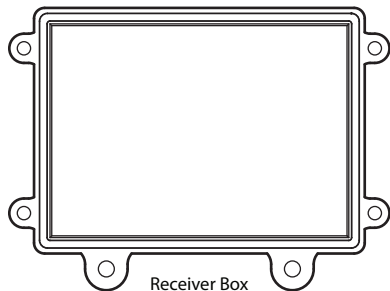

Receiver Box



Battery Strap x 2

**1 CHASSIS**

- M3x18 CSS x 4
- M3x10 RS x 2
- D3x6x5 Tapered Spacer x 4

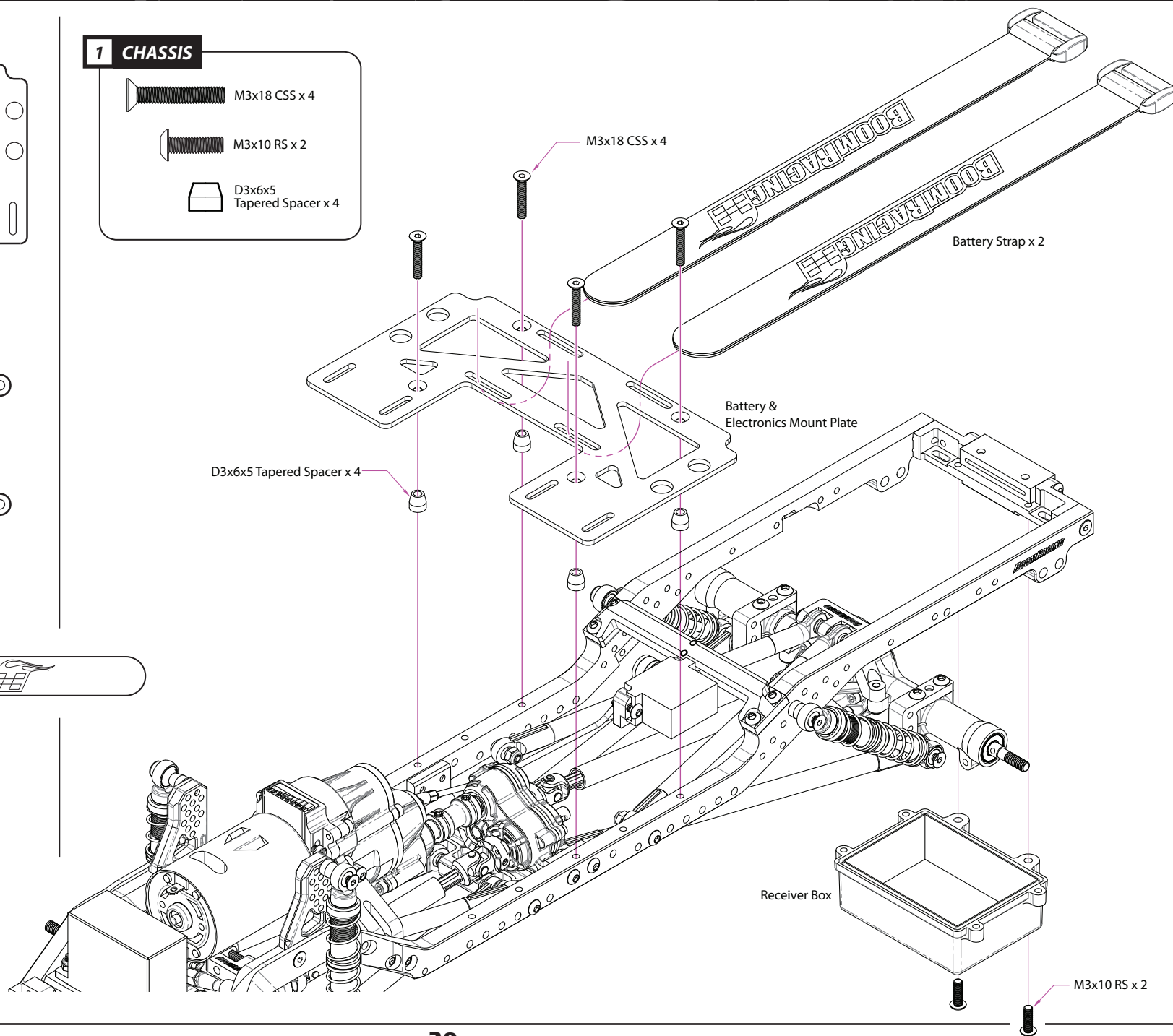

# 11 - ELECTRONICS INSTALLATION

# BAXO

## 7 BODY MOUNTS



M4x12 SC x 2



Electronics Installation  
(Suggested Layout)

M4x12 SC x 2

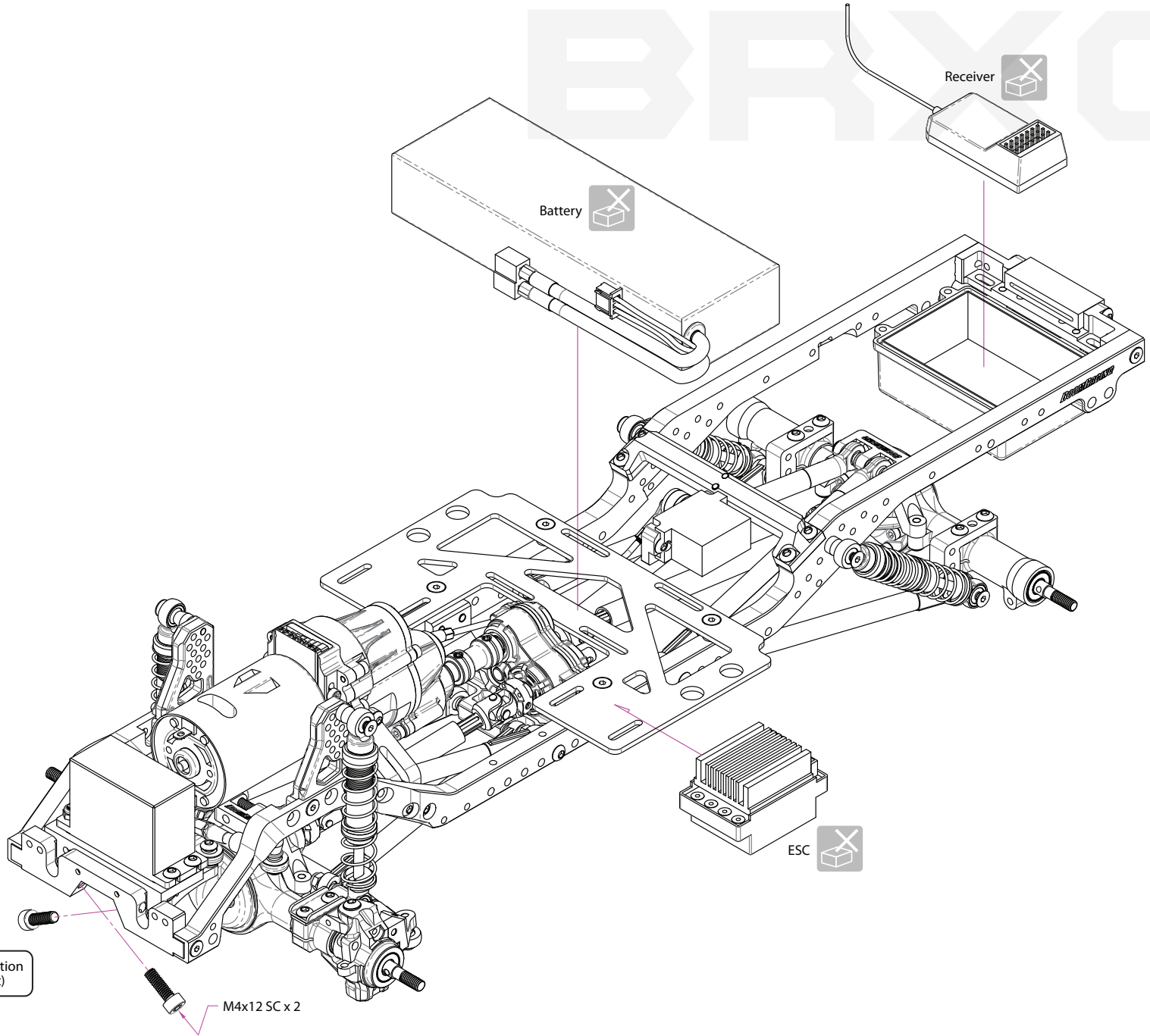

Battery

Receiver

ESC

ELECTRONICS

ELECTRONICS

# 12 - RECEIVER BOX WIRING & SEALING

Parts Needed:

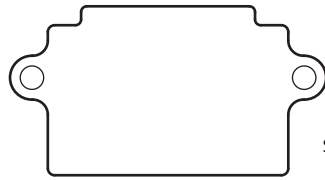

Stainless Steel Sealing Cap

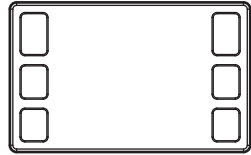

Silicone Port

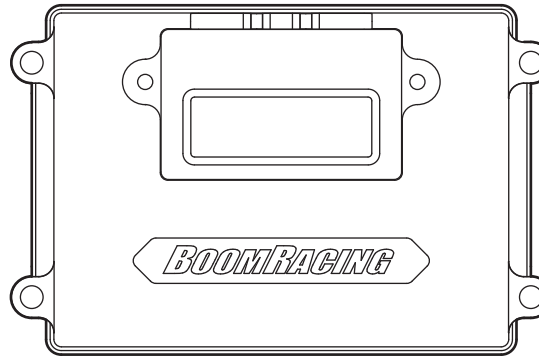

Receiver Box Lid

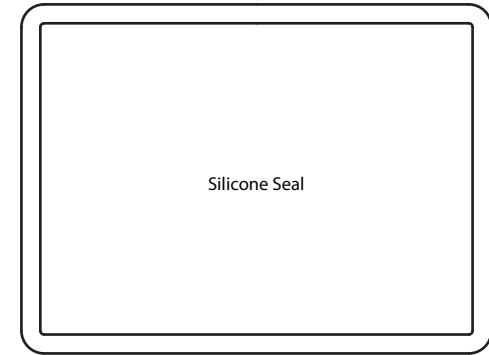

Silicone Seal

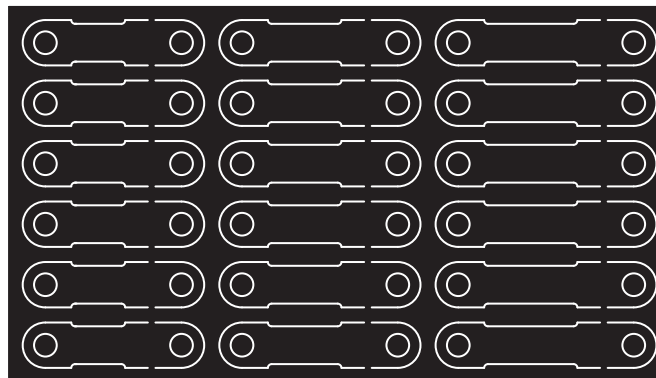

Tying diameter  $\varnothing$ 3.3mm  
holds 2 servo cables

Tying diameter  $\varnothing$ 4.1mm  
holds 3 servo cables

Tying diameter  $\varnothing$ 4.9mm  
holds 4 servo cables or  
1 pair 14 gauge power cable

Cable Wiring Retainer  
18 pieces / Use M2.5 or M3 Round Head Bolts

BRX01

**6 RECEIVER BOX**

M3x8 RS x 4

M2.5x6 RS x 2



Apply Siliking Grease around and into the silicone sealing to create an airtight seal.

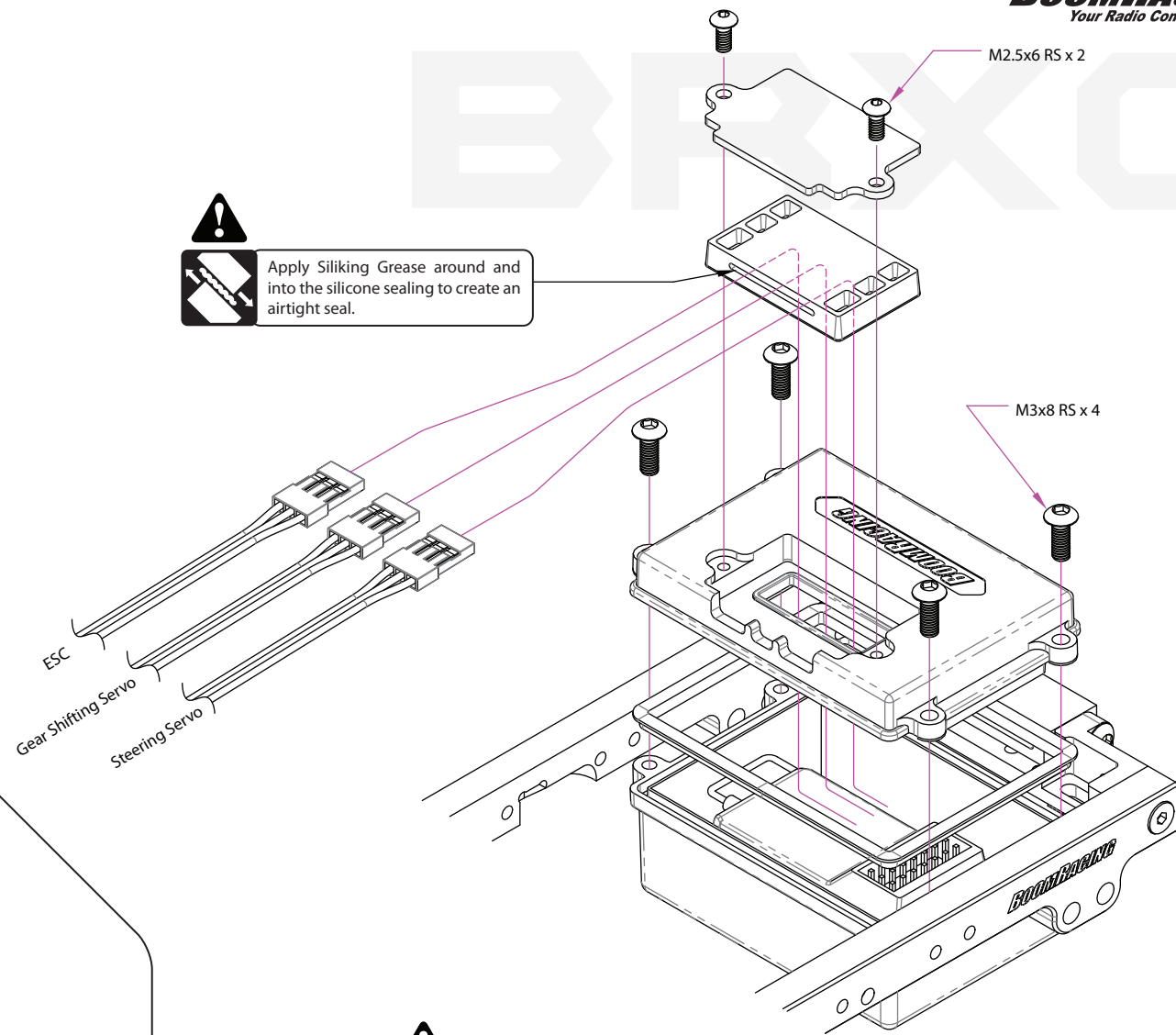

**CABLE WIRING RETAINER**

Step 1  
Select appropriate retainer length.



Step 2  
Install with screws.

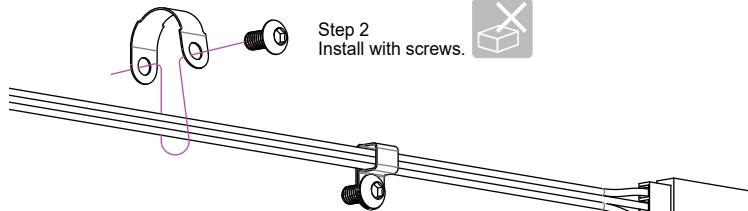

Step 3  
Carefully tighten the screw to avoid snapping the cable.



To fully waterproof the receiver box, apply a generous amount of Siliking Grease into and around the two silicone sealings to create an airtight seal.

The BRX01 is designed to go anywhere. This includes being fully submerged under water. To protect electronics from water damage, all electronics must be fully waterproofed. It is your responsibility to fully waterproof all electronics before driving in wet conditions.

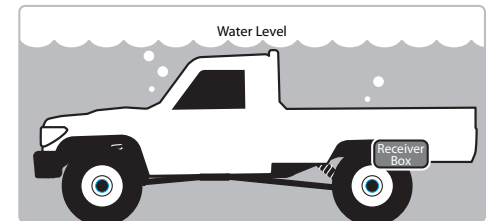

# 13 - WHEELS & TIRES

Parts Needed:

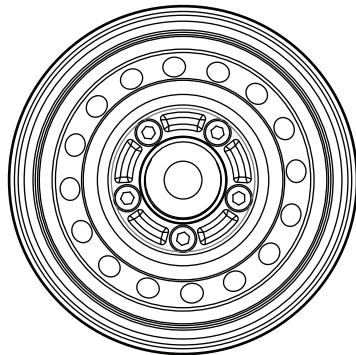

Steelie Wheels x 4

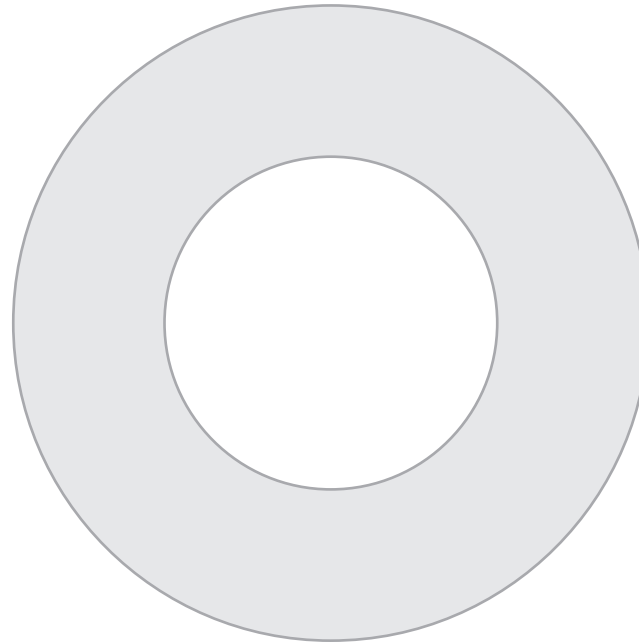

1.55 Single Stage Open Cell Foam Insert 84x23mm  
for 1.55 SP ROAD TRACKER™ Crawler Tire x 4  
#BRTR35501

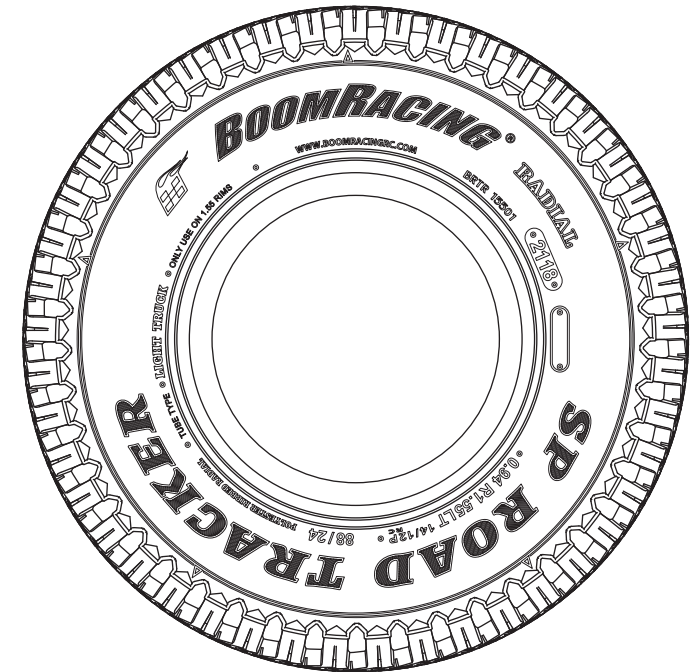

1.55 SP ROAD TRACKER™ Crawler Tire GEKKO Compound  
3.46x0.94 Inch (88x24mm) x 4

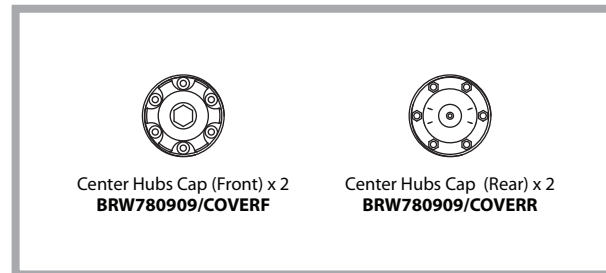

Center Hubs Cap (Front) x 2  
BRW780909/COVERF

Center Hubs Cap (Rear) x 2  
BRW780909/COVERR

## 8 WHEELS



Hex Adapter x 4



M3x3 SS x 4



M4 Nuts - Nyloc x 4



2x10mm Pin x 4

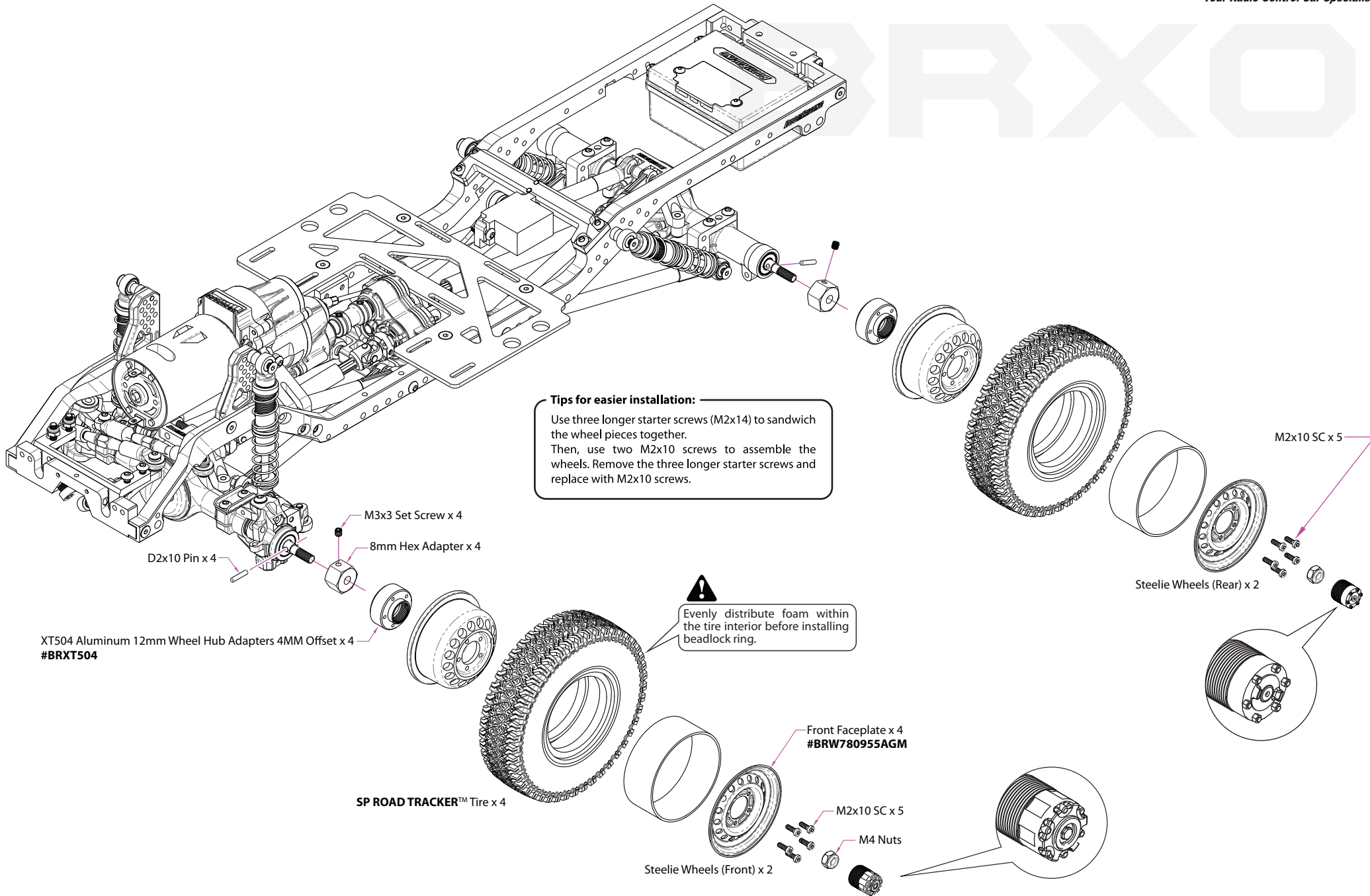

**Tips for easier installation:**  
Use three longer starter screws (M2x14) to sandwich the wheel pieces together. Then, use two M2x10 screws to assemble the wheels. Remove the three longer starter screws and replace with M2x10 screws.

**!** Evenly distribute foam within the tire interior before installing beadlock ring.

M3x3 Set Screw x 4  
8mm Hex Adapter x 4  
D2x10 Pin x 4

XT504 Aluminum 12mm Wheel Hub Adapters 4MM Offset x 4  
#BRXT504

SP ROAD TRACKER™ Tire x 4

Steelie Wheels (Front) x 2

Front Faceplate x 4  
#BRW780955AGM

M2x10 SC x 5

M4 Nuts

M2x10 SC x 5

Steelie Wheels (Rear) x 2

# 14 - LC70 BODY SECTION

Use the diagram below to sketch the design scheme for your LC70 hard body before painting. If you would like to download this file, go to the Downloads tab at <https://www.boomracingrc.com/BRX01>. Refer to the Killerbody LC70 Hard Body manual to assemble the body before continuing to the next steps.

\*Body Only Included in BRX01 With LC70 Body #BR8002

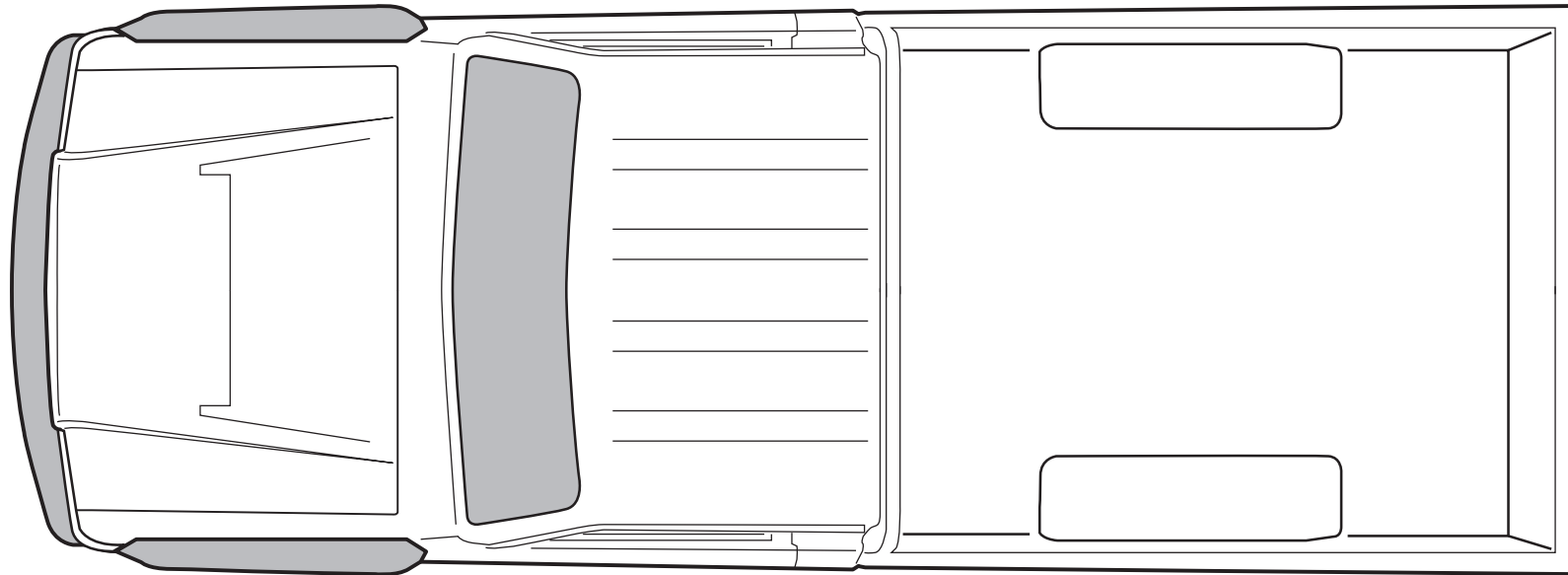
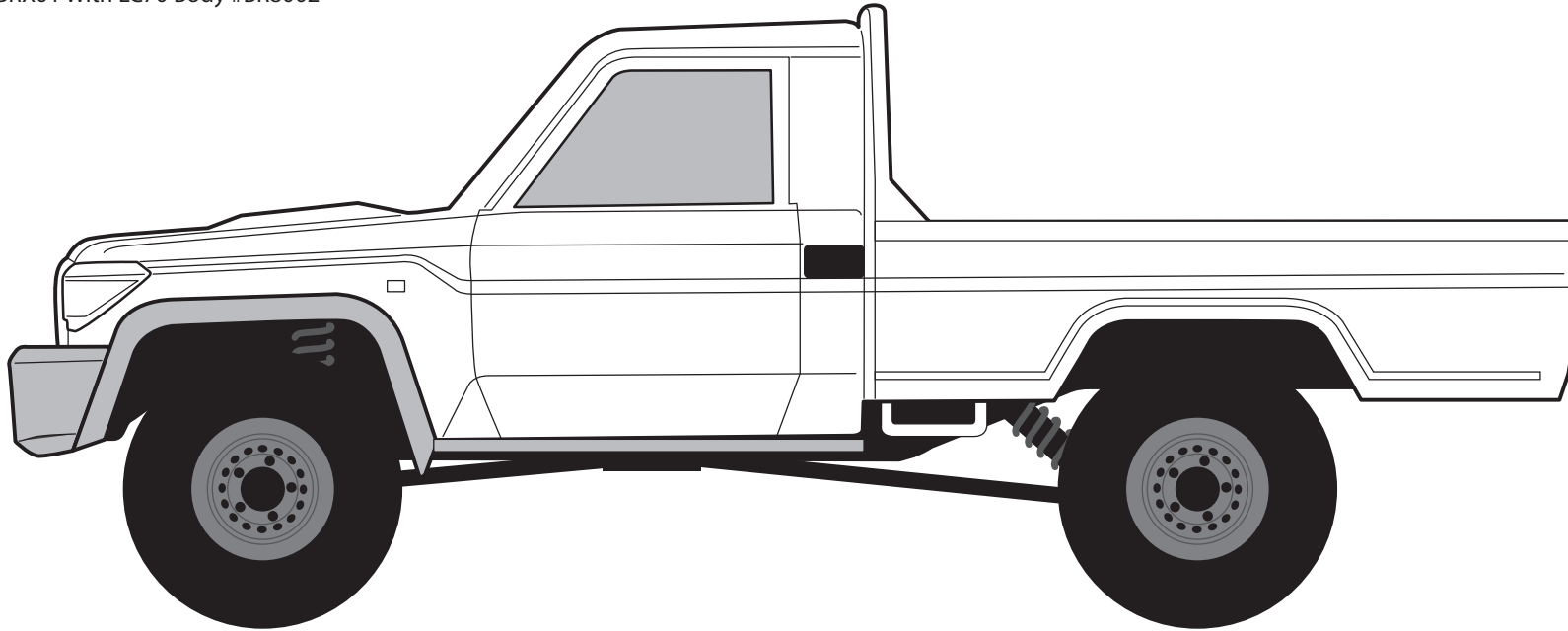

LC70 BODY SECTION

LC70 BODY SECTION

# 15 - LC70 FRONT BODY MOUNT

Parts Needed:

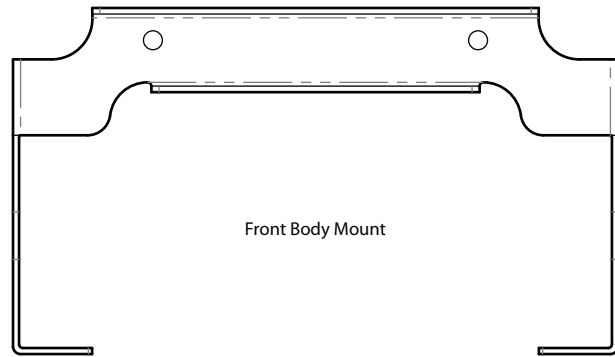

Front Body Mount



Refer to the Killerbody LC70 manual to assemble the body before continuing on this page.

M3x12 Self Tapping Screw x 2

M2.5x8 SC x 2

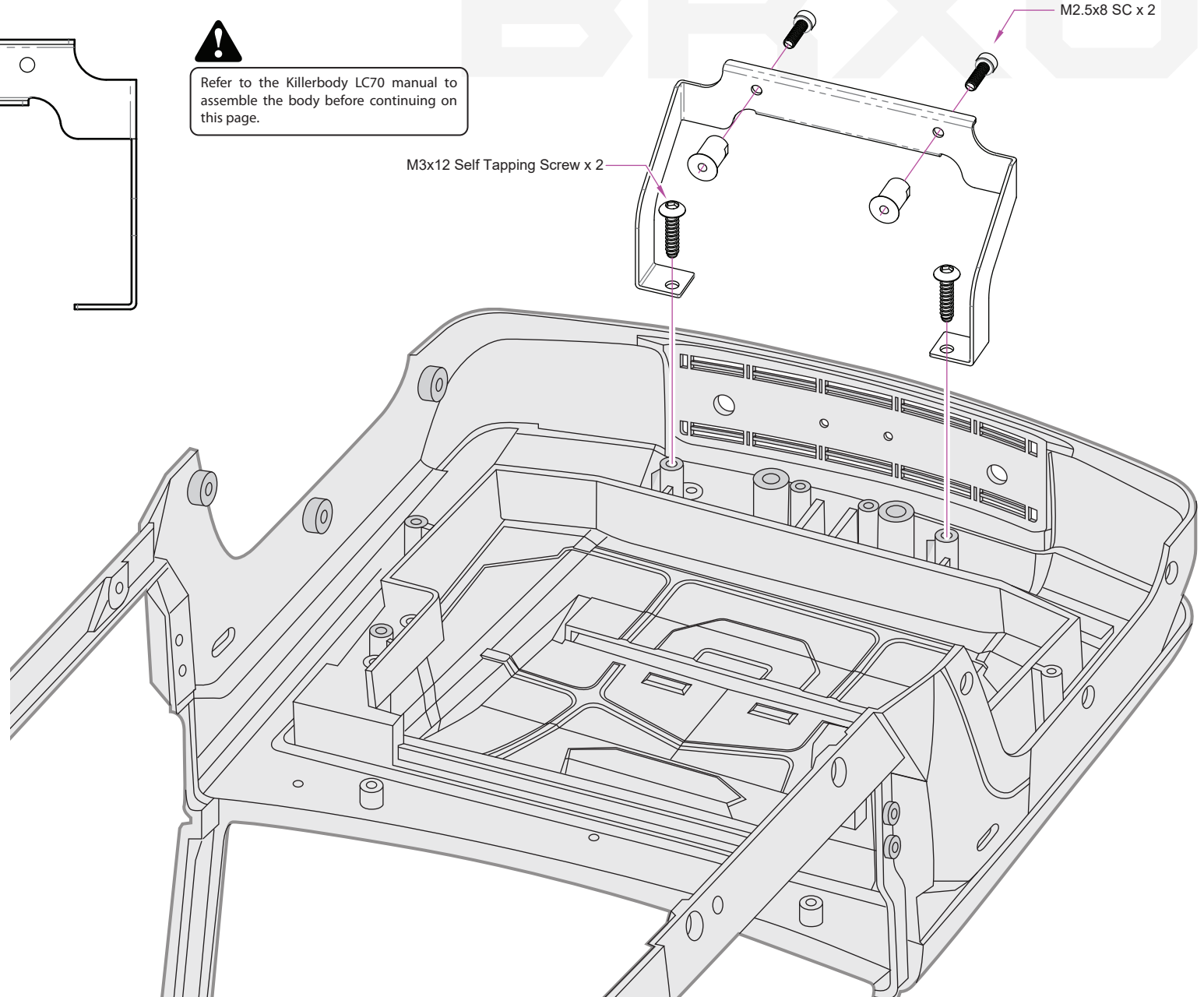

## 7 BODY MOUNTS

 M3x12 Self Tapping x 2

 M2.5x8 SC x 2

 Cross Bar x 2

# 16 - LC70 REAR BODY MOUNT

Parts Needed:

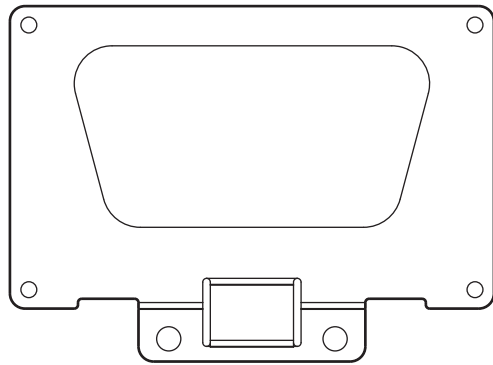

Rear Body Mount

## 7 BODY MOUNTS

 M2x5 SC x 4

 M2 Nuts x 4

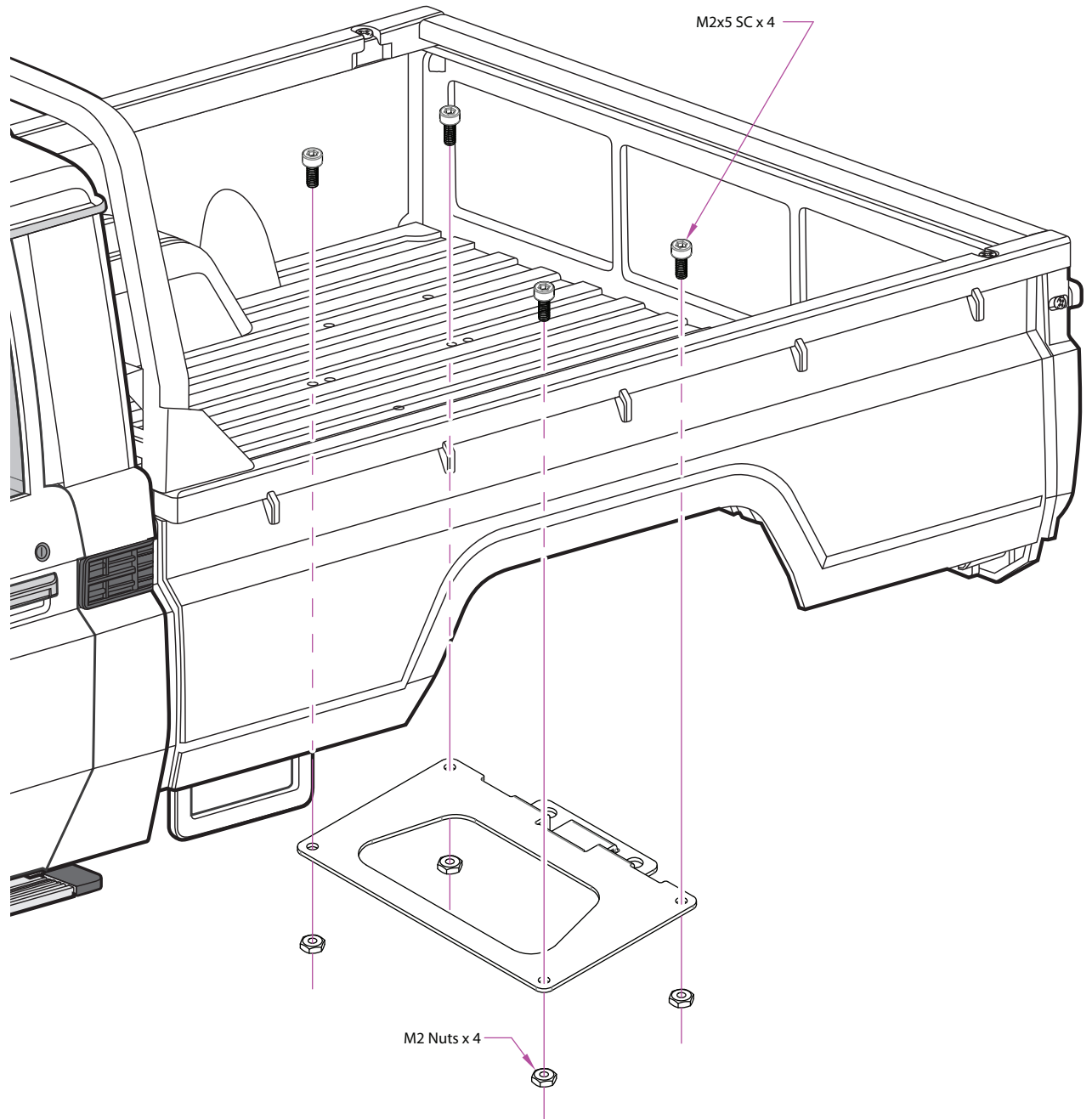

LC70 BODY MOUNTS

LC70 BODY MOUNTS

# 17 - LC70 FRONT & REAR BODY MOUNT

LC70 BODY MOUNTS

LC70 BODY MOUNTS

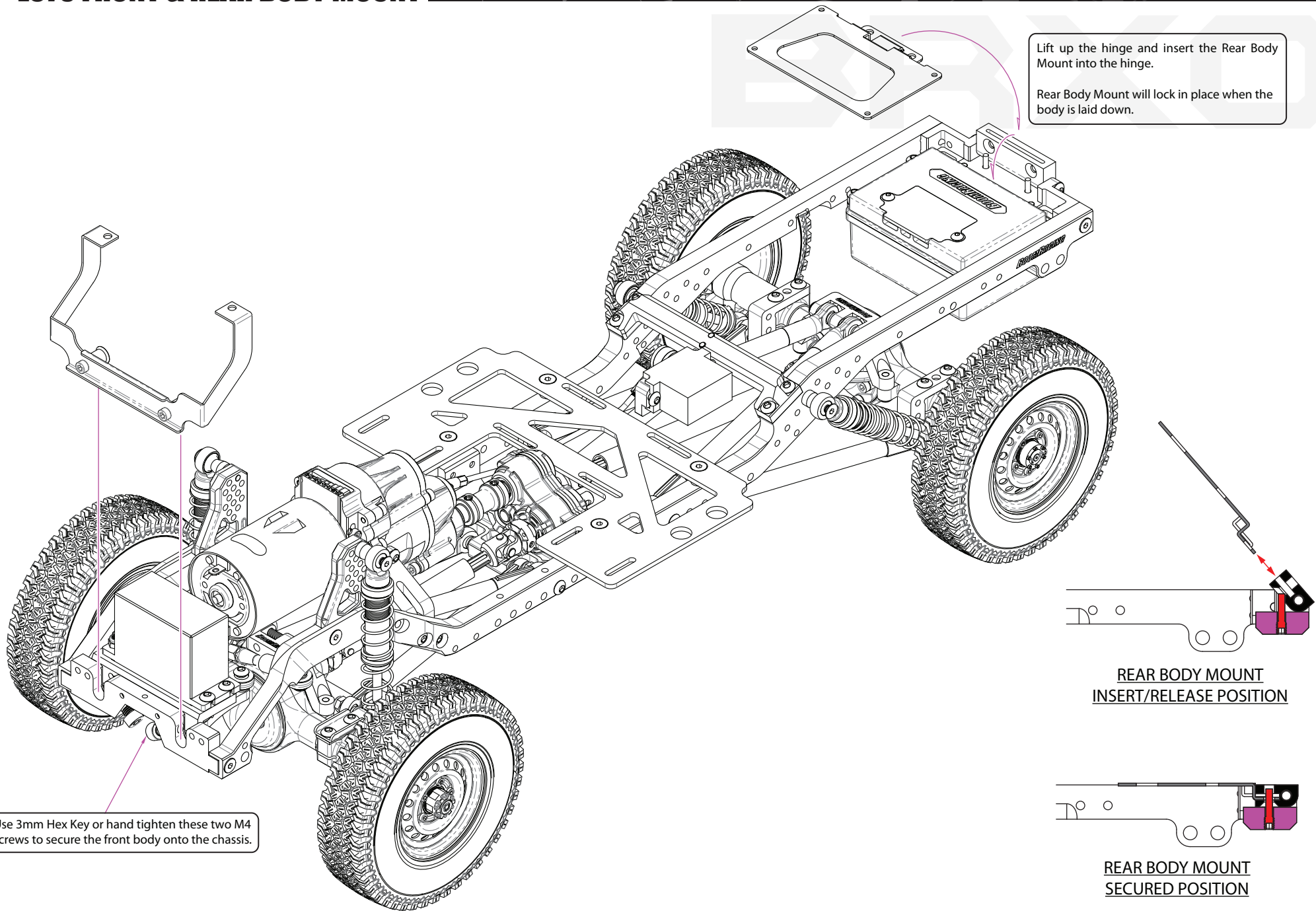

# 18 - OPTIONAL FRONT SHOCK TOWER SETUP

OPTIONAL FRONT SHOCK TOWER SETUP

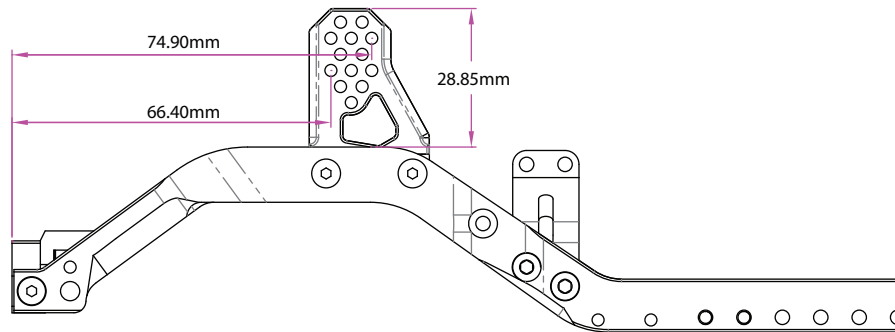

OPTIONAL FRONT SHOCK TOWER SETUP

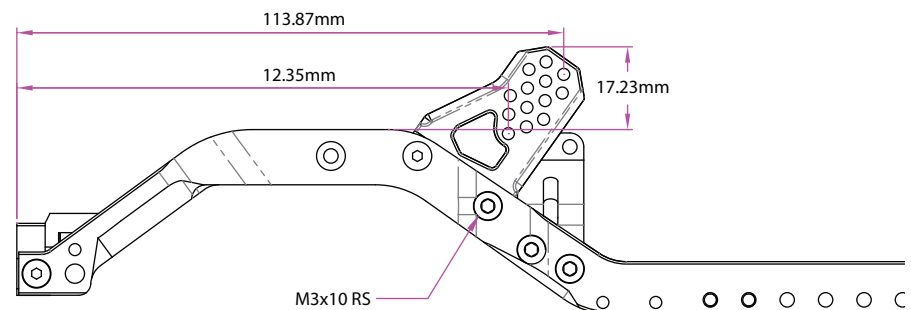
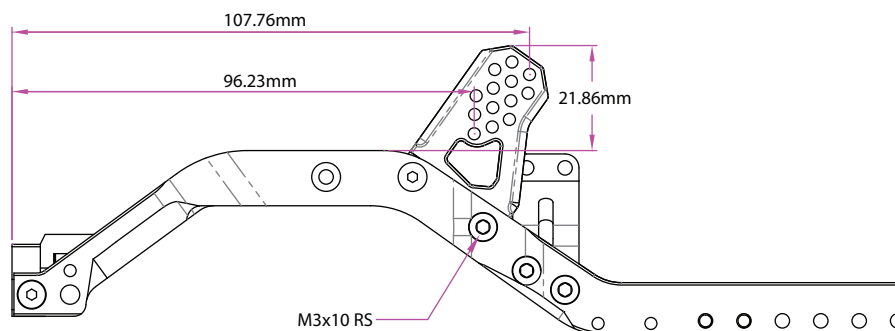
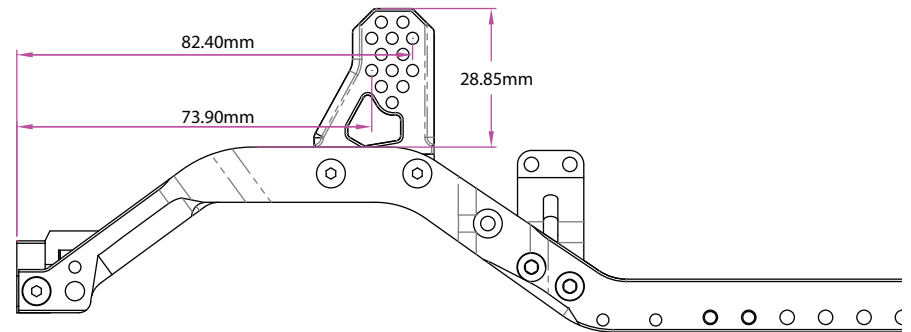

DEFAULT SETUP



**PRE-ASSEMBLED FRONT AXLE**

  Apply a generous amount of Black Grease on all movable contact surfaces including gears, spacers, shafts and bearings.

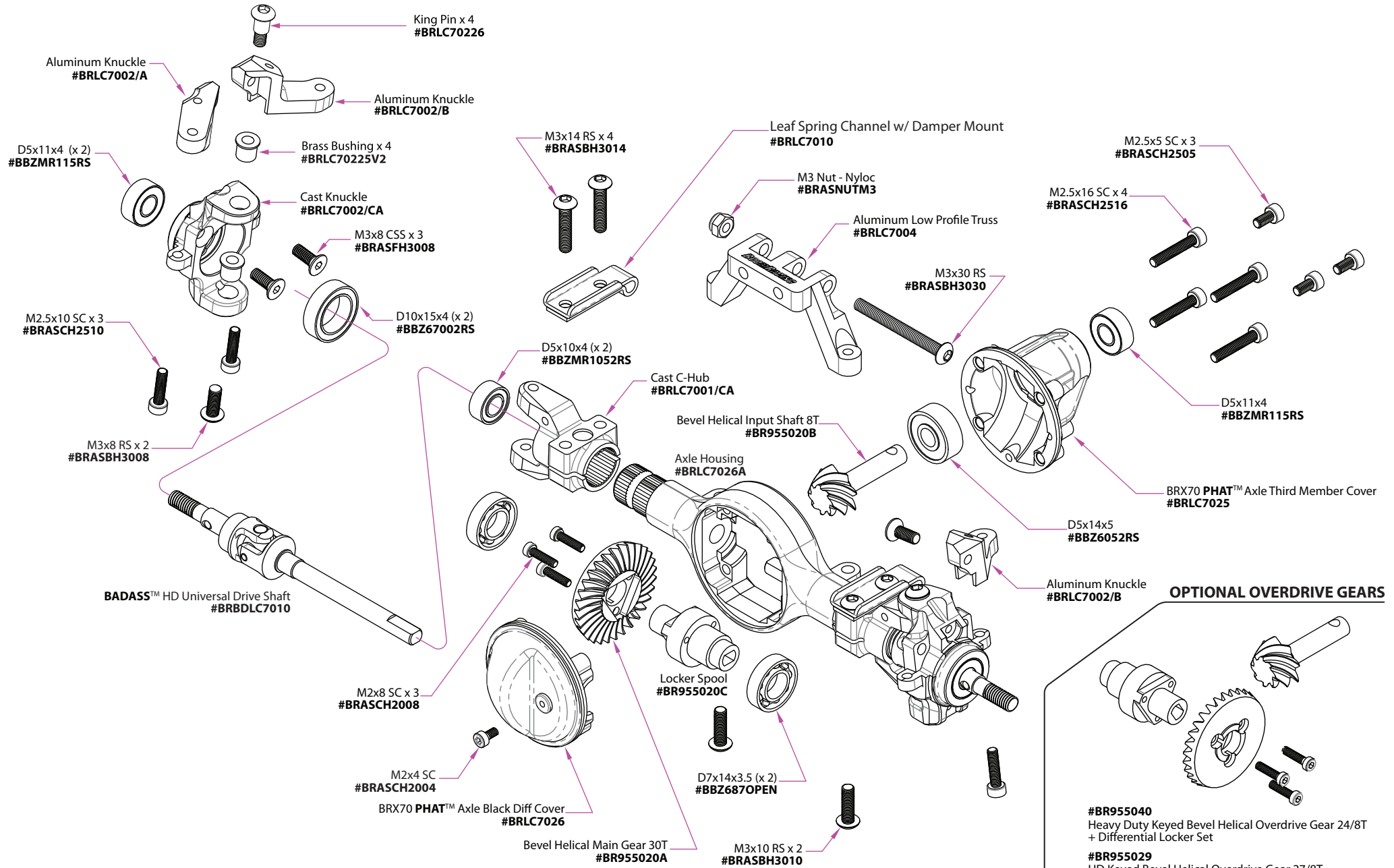

**OPTIONAL OVERDRIVE GEARS**

#BR955040  
Heavy Duty Keyed Bevel Helical Overdrive Gear 24/8T + Differential Locker Set

#BR955029  
HD Keyed Bevel Helical Overdrive Gear 27/8T + Differential Locker Set

PRE-ASSEMBLED PARTS

PRE-ASSEMBLED PARTS



**PRE-ASSEMBLED BCF2™ GEARBOX**



Apply a generous amount of Black Grease on all movable contact surfaces including gears, spacers, shafts and bearings.

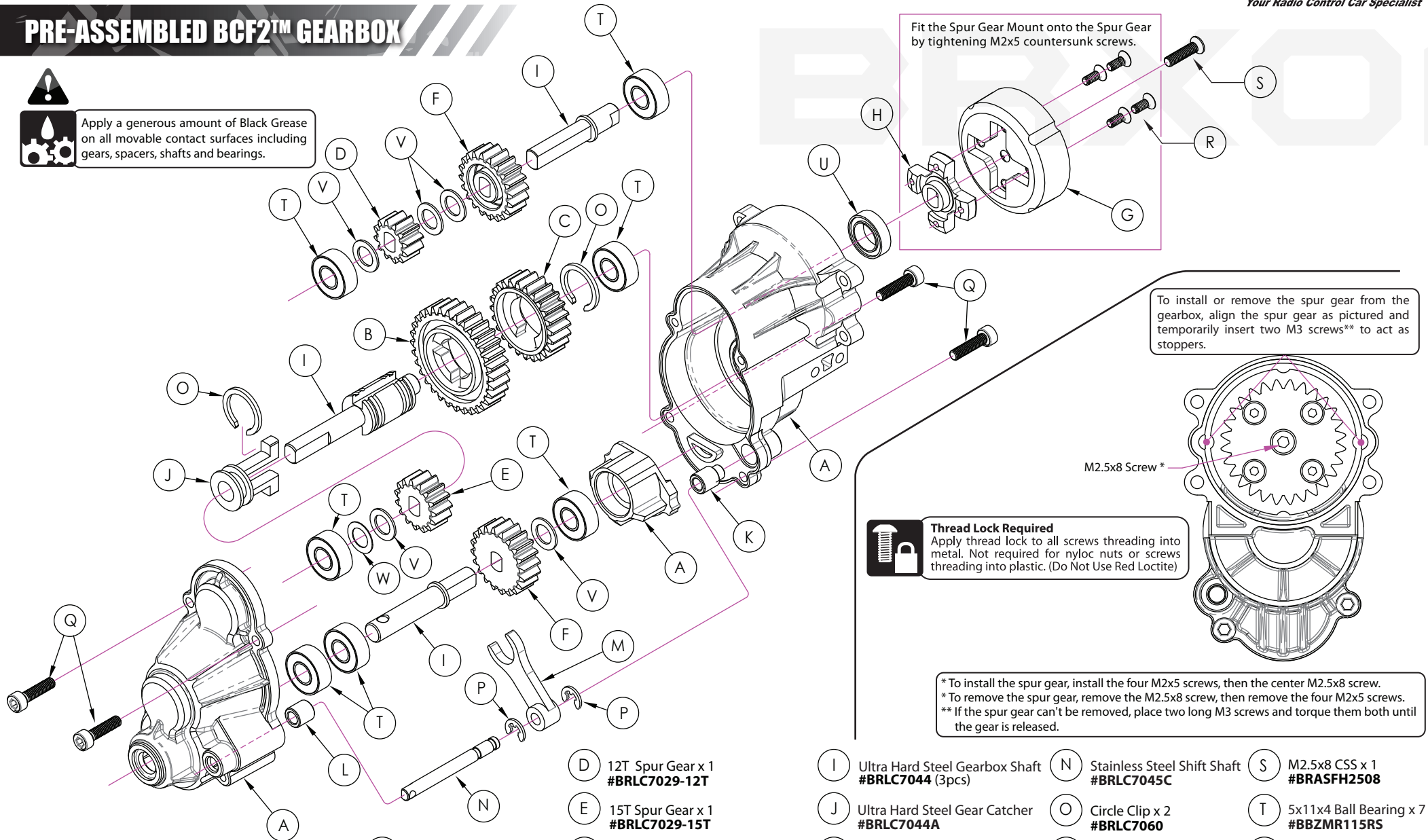

Fit the Spur Gear Mount onto the Spur Gear by tightening M2x5 countersunk screws.

To install or remove the spur gear from the gearbox, align the spur gear as pictured and temporarily insert two M3 screws\*\* to act as stoppers.

M2.5x8 Screw \*

**Thread Lock Required**  
Apply thread lock to all screws threading into metal. Not required for nyloc nuts or screws threading into plastic. (Do Not Use Red Loctite)

\*To install the spur gear, install the four M2x5 screws, then the center M2.5x8 screw.  
\*To remove the spur gear, remove the M2.5x8 screw, then remove the four M2x5 screws.  
\*\* If the spur gear can't be removed, place two long M3 screws and torque them both until the gear is released.

- |  |  |   |   |
|--|--|---|---|
| (D) 12T Spur Gear x 1<br>#BRLC7029-12T         | (I) Ultra Hard Steel Gearbox Shaft<br>#BRLC7044 (3pcs) | (N) Stainless Steel Shift Shaft<br>#BRLC7045C | (S) M2.5x8 CSS x 1<br>#BRASFH2508           |
| (E) 15T Spur Gear x 1<br>#BRLC7029-15T         | (J) Ultra Hard Steel Gear Catcher<br>#BRLC7044A        | (O) Circle Clip x 2<br>#BRLC7060              | (T) 5x11x4 Ball Bearing x 7<br>#BBZMR115RS  |
| (A) Aluminum Gearbox Case<br>#BRLC7029 (3pcs)  | (K) Brass End Cap x 1<br>#BRLC7045A                    | (P) E - Clip x 2<br>#BRASEC30                 | (U) 7x11x3 Ball Bearing x 1<br>#BBZMR1172RS |
| (B) 32T Slotted Spur Gear x 1<br>#BRLC7029-32T | (L) Brass Bushing x 1<br>#BRLC7045A                    | (Q) M2.5x10 SC x 4<br>#BRASCH2510             | (V) 0.5mm Spacer x 5<br>#BRASSPD5805        |
| (C) 24T Slotted Spur Gear x 1<br>#BRLC7029-24T | (H) Ultra Hard Steel Spur Gear Mount<br>#BRLC7030      | (R) M2x5 CSS x 4<br>#BRASFH2005               | (W) Fine Tune Spacer                        |
| (F) 20T Spur Gear x 2<br>#BRLC7029-20T         | (M) Ultra Hard Steel Shifter<br>#BRLC7045B             |   |   |

PRE-ASSEMBLED PARTS

PRE-ASSEMBLED PARTS

# PRE-ASSEMBLED SRD™ TRANSFER CASE



Apply a generous amount of Black Grease on all movable contact surfaces including gears, spacers, shafts and bearings.

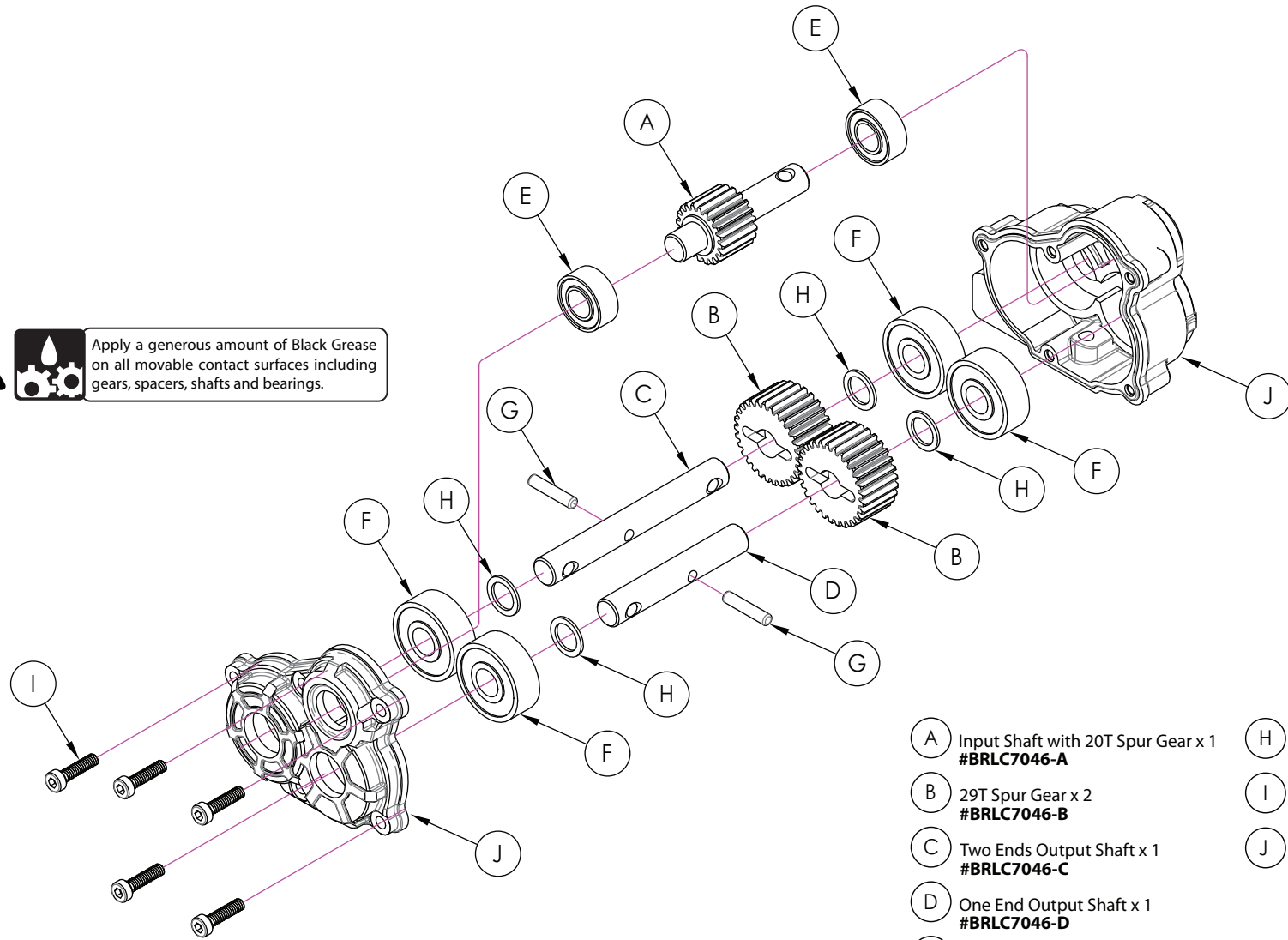

- (A) Input Shaft with 20T Spur Gear x 1  
#BRLC7046-A
- (B) 29T Spur Gear x 2  
#BRLC7046-B
- (C) Two Ends Output Shaft x 1  
#BRLC7046-C
- (D) One End Output Shaft x 1  
#BRLC7046-D
- (E) D5 x 10 x 4mm Bearing x 2  
#BBZMR1052RS
- (F) D5 x 14 x 5mm Bearing x 4  
#BBZ6052RS
- (G) D2 X 10mm Pin x 2  
#BRASPIN210
- (H) 0.5mm Spacer x 4  
#BRASSPD5805
- (I) M2x8 SC x 5  
#BRASCH2008
- (J) Cast Aluminum Transfer Case Housing  
#BRLC7047/CA (2pcs)

PRE-ASSEMBLED PARTS

PRE-ASSEMBLED PARTS

### OPTIONAL FRONT SKID PLATE #BRLC7061

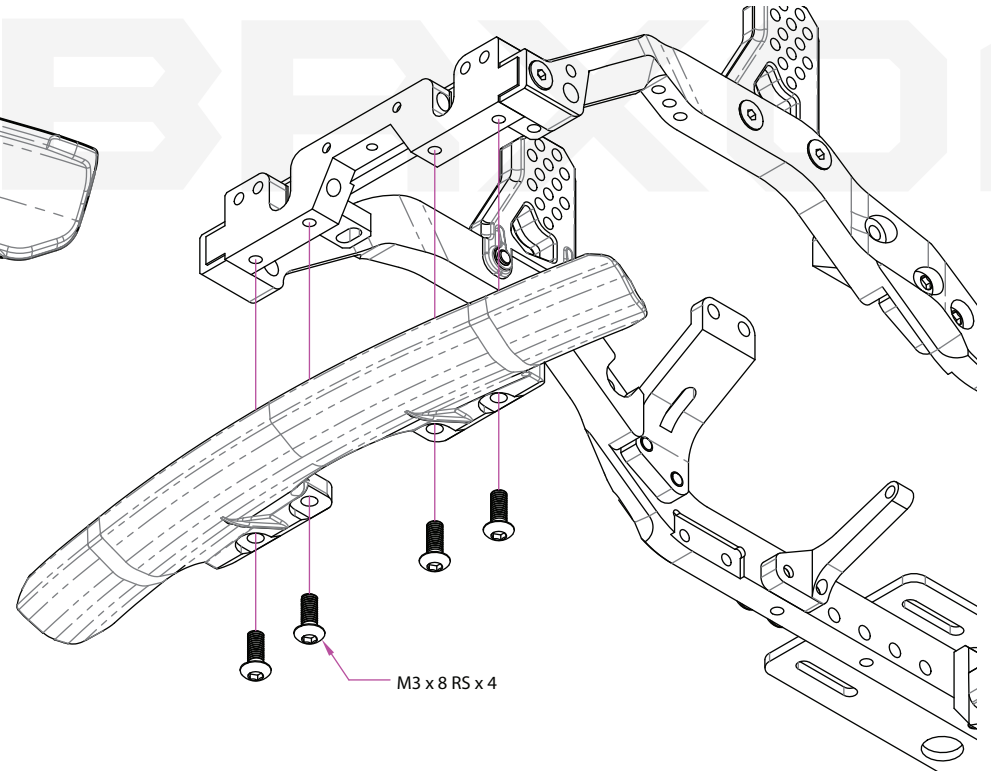
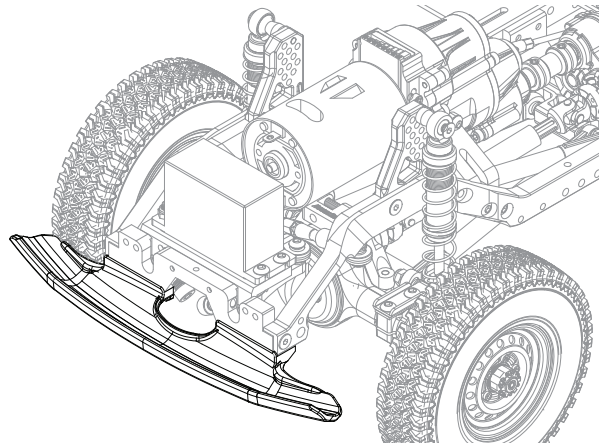
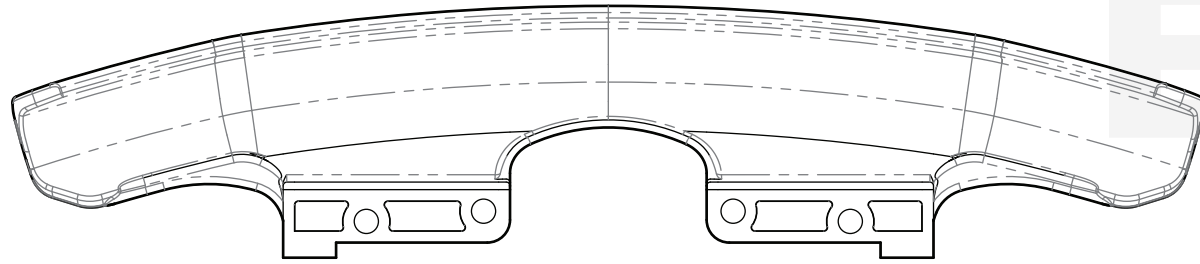

OPTIONAL PARTS

OPTIONAL PARTS

### OPTIONAL "TOOL FREE" QUICK RELEASE LATCH #BRLC7062

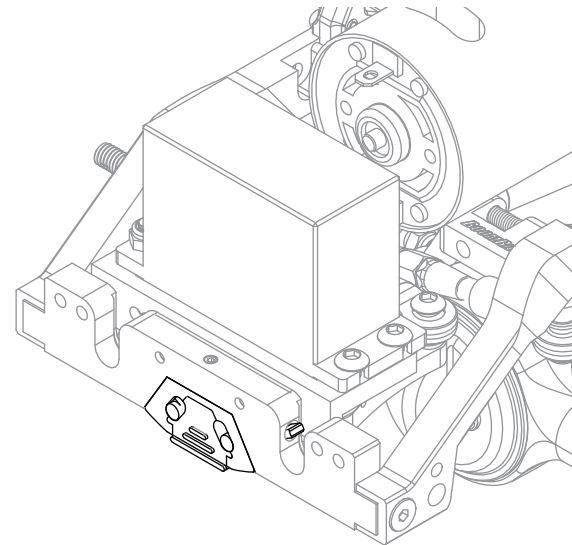
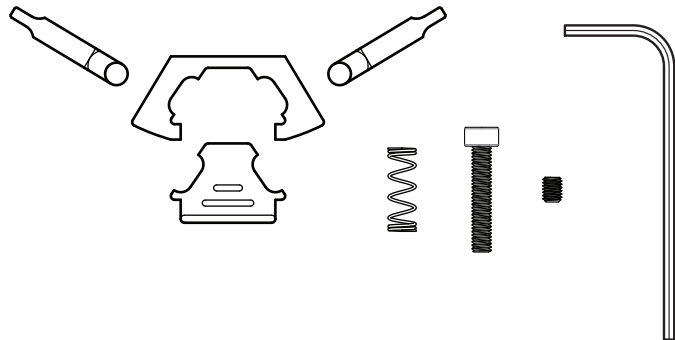

# PARTS LIST

Parts shown in bold are optional accessories. Parts are arranged in alphanumeric order.

Part #	Description	Part #	Description
BBZ6052RS	5x14x5mm High Performance Rubber Sealed Bearing (1)	BRASFH3018	M3x18 CSS Counter Sunk Screw (10)
BBZ67002RS	10x15x4mm High Performance Rubber Sealed Bearing (1)	BRASFH3020	M3x20 CSS Counter Sunk Screw (10)
BBZ6870PEN	7x14x3.5mm High Performance Open Ball Bearing (1)	BRASFH3022	M3x22 CSS Counter Sunk Screw (10)
BBZMR1052RS	5x10x4mm High Performance Rubber Sealed Bearing (1)	BRASFH3026	M3x26 CSS Counter Sunk Screw (10)
BBZMR1152RS	5x11x4mm High Performance Rubber Sealed Bearing (1)	BRASNUTM2	Lock Nut M2 (5)
BBZMR1172RS	7x11x3mm High Performance Rubber Sealed Bearing (1)	BRASNUTM3	Lock Nut M3 Nyloc (5)
BBZMR952RS	5x9x3mm High Performance Rubber Sealed Bearing (1)	BRASNUTM4	Lock Nut M4 Nyloc (5)
BR955020	HD Steel Keyed Bevel Helical Gear 30/8T & Diff Locker Spool Set	BRASORD8-15	D8x1.5 Rubber O-Ring (10)
BR955020A	HD Steel Bevel Helical Main Gear 30T for BR955020	BRASPIN210	Steel Pin 2x10mm (10)
BR955020B	HD Steel Bevel Helical Input Shaft 8T for BR955020	BRASSPD427/N	D4x7x2 Nylon Spacer (5)
BR955020C	HD Steel Locker Spool for BR955020 BR955029 BRLC7039	BRASSPD471/N	D4x7x1 Nylon Spacer (5)
<b>BR955029</b>	<b>Overdrive HD Steel Keyed Bevel Helical Gear 27/8T &amp; Diff Locker Spool Set</b>	BRASSPD5727	D5x7x2.7 Spacer (5)
<b>BR955029A</b>	<b>Overdrive HD Bevel Helical Main Gear 27T for BR955029</b>	BRASSPD5801	D5x8x0.1 Spacer (10)
<b>BR955029B</b>	<b>Overdrive HD Bevel Helical Input Shaft 8T for BR955029</b>	BRASSPD5805	D5x8x0.5 Spacer (10)
BRASBH2007	M2x7 RS Round Head Screw (10)	BRASST3003	M3x3 SS Steel Set Screws (10)
BRASBH2008	M2x8 RS Round Head Screw (10)	BRASST3012/DS	M3x12 SS Steel Driveshaft Screw Pin (5)
BRASBH2506	M2.5x6 RS Round Head Screw (10)	BRASST4016	M4x16 SS Steel Set Screw (10)
BRASBH3006	M3x6 RS Round Head Screw (10)	BRBDLC7010	<b>BADASS™</b> HD Steel Universal Drive Shaft for BRX70 PHAT™ Axle (2)
BRASBH3008	M3x8 RS Round Head Screw (10)	BRBDLC7011	<b>BADASS™</b> HD Steel Rear Shaft for BRX70 PHAT™ Axle (2)
BRASBH3010	M3x10 RS Round Head Screw (10)	BRGRS01	<b>BADASS™</b> Siliking Grease 5g
BRASBH3012	M3x12 RS Round Head Screw (10)	BRGRS08	<b>BADASS™</b> Black Graphite Grease 5g
BRASBH3012/ST	M3x12 Self Tapping Screw (10)	BRGRS10	Artificial Leather Lock Strap (2)
BRASBH3014	M3x14 RS Round Head Screw (10)	<b>BRGRS242</b>	<b>242 Blue Thread Lock 10g</b>
BRASBH3016	M3x16 RS Round Head Screw (10)	BRLC7001/CA	Cast Metal C-Hub for BRX70 Axle (2)
BRASBH3018	M3x18 RS Round Head Screw (10)	BRLC7002/A	Aluminum Knuckle Lever for BRX70 Knuckle (1)
BRASBH3024	M3x24 RS Round Head Screw (10)	BRLC7002/B	Aluminum Knuckle Arm for BRX70 Knuckle (2)
BRASBH3030	M3x30 RS Round Head Screw (10)	BRLC7002/CA	Cast Metal Knuckle for BRX70 Axle (2)
BRASCH2004	M2x4 SC Socket Cap Screw (10)	BRLC7003	SST Steering Link Tie Rod w/ <b>BADASS™</b> Rod Ends for BRX70 PHAT™ Axle
BRASCH2005	M2x5 SC Socket Cap Screw (10)	BRLC7004	Aluminum Low Profile Truss for BRX70 PHAT™ Axle
BRASCH2008	M2x8 SC Socket Cap Screw (10)	BRLC7005	Aluminum Link Mount for BRX70 PHAT™ Axle (2)
BRASCH2505	M2.5x5 SC Socket Cap Screw (10)	BRLC7006/CA	Cast Metal Lockout for BRX70 PHAT™ Axle (2)
BRASCH2508	M2.5x8 SC Socket Cap Screw (10)	BRLC7008	Aluminum Gearbox End Mount
BRASCH2510	M2.5x10 SC Socket Cap Screw (10)	BRLC7009	Aluminum 2 Speed Shift Servo Mount
BRASCH2516	M2.5x16 SC Socket Cap Screw (10)	BRLC7010	Leaf Spring Channel w/ Shock Mount (2)
BRASCH3008	M3x8 SC Socket Cap Screw (10)	BRLC7011	Aluminum Billet Chassis Rail 7mm Left & Right (2)
BRASCH4012	M4x12 SC Socket Cap Screw (10)	BRLC7012	Aluminum Rear Crossmember
BRASEC30	E-Clip 3mm (10)	BRLC7013	Aluminum Rear Body Hinge Mount
BRASFH2005	M2x5 CSS Counter Sunk Screw (10)	BRLC7014	Aluminum Middle Crossmember
BRASFH2010	M2x10 CSS Counter Sunk Screw (10)	BRLC7015	Aluminum Front Crossmember
BRASFH2508	M2.5x8 CSS Counter Sunk Screw (10)	BRLC7016	Aluminum Steering Servo Mount
BRASFH3008	M3x8 CSS Counter Sunk Screw (10)	BRLC7018	Aluminum Shock Mount Left & Right (2)
BRASFH3010	M3x10 CSS Counter Sunk Screw (10)	BRLC7019	Aluminum Gearbox Side Mount (2)
BRASFH3012	M3x12 CSS Counter Sunk Screw (10)	BRLC7020	Aluminum High Clearance Skid Plate

# PARTS LIST

Part #	Description	Part #	Description
BRLC7021	Aluminum Battery & Electronics Mount Plate	BRLC7055	Aluminum Long Low Profile Servo Horn 25T Black
BRLC7022A	Brass Bushing for BRX70 Knuckle (4)	BRLC7056	8mm Aluminum 12mm Hex Adaptors with Pins & Set Screws (4) Black
BRLC7024	BRX70 PHAT™ Axle Housing with Diff Cover (Black)	BRLC7057	BRX70 Complete Front PHAT™ Axle w/ 30/8T HD Keyed Gear & BADASS™ HD Uni. Drive Shaft
BRLC7025	BRX70 PHAT™ Axle Third Member Cover	BRLC7058	BRX70 Complete Rear PHAT™ Axle w/ Reversed 30/8T HD Keyed Gear & BADASS™ HD Steel Shaft
BRLC7026	BRX70 PHAT™ Axle Diff Cover (Black)	BRLC7059	Extension Cable x 2
BRLC7026A	BRX70 PHAT™ Axle Housing	BRLC7060	Circle Clip x 5
BRLC7027	Aluminum Gearbox Adapter with Motor Mount	<b>BRLC7061</b>	<b>Front Skid Plate</b>
BRLC7028	Stainless Steel Connection Shaft	<b>BRLC7062</b>	<b>"Tool Free" Quick Release Latch</b>
BRLC7029	Aluminum BCF2™ Gearbox Housing	<b>BRPG3209-3</b>	<b>32P 9T / 3.175mm Steel Pinion Gear (1)</b>
BRLC7029-12T	Heavy Duty 12T Steel Cut Gear (1)	<b>BRPG3210-3</b>	<b>32P 10T / 3.175mm Steel Pinion Gear (1)</b>
BRLC7029-15T	Heavy Duty 15T Steel Cut Gear (1)	<b>BRPG3211-3</b>	<b>32P 11T / 3.175mm Steel Pinion Gear (1)</b>
BRLC7029-20T	Heavy Duty 20T Steel Cut Gear (1)	BRPG3212-3	32P 12T / 3.175mm Steel Pinion Gear (1)
BRLC7029-24T	Heavy Duty 24T Steel Cut Gear (1)	<b>BRPG3213-3</b>	<b>32P 13T / 3.175mm Steel Pinion Gear (1)</b>
BRLC7029-32T	Heavy Duty 32T Steel Cut Gear (1)	<b>BRPG3214-3</b>	<b>32P 14T / 3.175mm Steel Pinion Gear (1)</b>
BRLC7030	Ultra-Hard Steel Spur Gear Mount (1)	<b>BRPG3215-3</b>	<b>32P 15T / 3.175mm Steel Pinion Gear (1)</b>
BRLC7031	Internal Spur Gear 28T 32 Pitch (1)	<b>BRPG3216-3</b>	<b>32P 16T / 3.175mm Steel Pinion Gear (1)</b>
BRLC7032	Steel Motor Spacer	<b>BRPG32COMBO1-3</b>	<b>32P Steel Pinion Gear Combo 9T-12T (4)</b>
BRLC7033	Receiver Box Kit	<b>BRPG32COMBO2-3</b>	<b>32P Steel Pinion Gear Combo 13T-16T (4)</b>
BRLC7033A	Silicone Seal for Receiver Box	BRQ763069/CA	Complete SRD™ Transfer Case
BRLC7034	M4 7mm Aluminum Links Set (7) 2x70mm/2x114/2x93mm/1x63mm	BRQ90279KIT	Rebuild Kit for Drive Shaft (2)
BRLC7039	HD Steel Reversed Keyed Bevel Helical Gear 30/8T & Diff Locker Spool Set	BRQ90351	D2 Ball End - M2 Link Rod Joint (2)
BRLC7039-30	HD Steel Reversed Bevel Helical Main Gear 30T	<b>BRSHK010</b>	<b>BADASS™ Silicone Shock Oil 10wt 60ml</b>
BRLC7039-8	HD Steel Reversed Helical Input Shaft 8T	<b>BRSHK015</b>	<b>BADASS™ Silicone Shock Oil 15wt 60ml</b>
BRLC7040	3x6x5 Tapper Spacer (4)	<b>BRSHK020</b>	<b>BADASS™ Silicone Shock Oil 20wt 60ml</b>
BRLC7041	3x6x3 Tapper Spacer (4)	<b>BRSHK025</b>	<b>BADASS™ Silicone Shock Oil 25wt 60ml</b>
BRLC7042	3x6x6 Tapper Spacer (4)	<b>BRSHK030</b>	<b>BADASS™ Silicone Shock Oil 30wt 60ml</b>
BRLC7043	Steel Center Drive Shafts (2) Front: 90-100mm Rear: 125-145mm	<b>BRSHK035</b>	<b>BADASS™ Silicone Shock Oil 35wt 60ml</b>
BRLC7044	Ultra-Hard Steel Gearbox Shaft (3)	<b>BRSHK040</b>	<b>BADASS™ Silicone Shock Oil 40wt 60ml</b>
BRLC7044A	Ultra-Hard Steel Gear Catcher	<b>BRSHK045</b>	<b>BADASS™ Silicone Shock Oil 45wt 60ml</b>
BRLC7045A	Brass Shifter Cap and Bushing	<b>BRSHK050</b>	<b>BADASS™ Silicone Shock Oil 50wt 60ml</b>
BRLC7045B	Ultra-Hard Steel Shifter	<b>BRSHK055</b>	<b>BADASS™ Silicone Shock Oil 55wt 60ml</b>
BRLC7045C	Stainless Steel Shift Rod	<b>BRSHK060</b>	<b>BADASS™ Silicone Shock Oil 60wt 60ml</b>
BRLC7046	HD Steel Cut Transfer Case Gear Set	<b>BRSHK065</b>	<b>BADASS™ Silicone Shock Oil 65wt 60ml</b>
BRLC7047/CA	Aluminum SRD™ Transfer Case Housing	<b>BRSHK070</b>	<b>BADASS™ Silicone Shock Oil 70wt 60ml</b>
BRLC7048A	Front Body Mount	<b>BRSHK075</b>	<b>BADASS™ Silicone Shock Oil 75wt 60ml</b>
BRLC7048B	Rear Body Mount	<b>BRSHK080</b>	<b>BADASS™ Silicone Shock Oil 80wt 60ml</b>
BRLC7048C	Stainless Steel Cross Bar (2)	BRSD6-15	D6x1.5 O-Ring (10)
BRLC7049	Aluminum 2 Speed Servo Horn Set	BRT10028	Tool Kit
BRLC7050	SST Counter Threaded Drag Link / Panhard Link for BRX70 PHAT™ Axle (2)	BRT10037	Cable Wiring Retainer (18pcs)
BRLC7051	Spring Steel Shift Rod	BRTR15501	1.55" <b>SP ROAD TRACKER™</b> Crawler Tire 3.46"x0.94" (88x24mm) <b>GEKKO</b> Compound w/ Single Stage Open Cell Foam Insert (2)
BRLC7052F	Front Aluminum Double Spring Shocks 80mm w/ Optional Soft Springs (2)	BRTR29395	1.55" Single Stage Open Cell Foam for 1.55" <b>SP ROAD TRACKER™</b> Crawler Tire (2)
BRLC7052R	Rear Aluminum Double Spring Shocks 80mm w/ Optional Soft Springs (2)	BRW750300	Stainless Steel Flanged Pivot Ball for Rod Ends (10)
BRLC7052-REBUILD	Rebuild Kit for Double Spring Shocks (2)	BRW750301	<b>BADASS™</b> HD Rust-Resistant Rod End M4 Nylon 20.0MM (Upwards)

# PARTS LIST

<b>Part #</b>	<b>Description</b>
BRW750302	<b>BADASS™</b> HD Rust-Resistant Rod End M4 Nylon 19.5mm (Sideways)
BRW750303	<b>BADASS™</b> HD Rust-Resistant Rod End M4 Nylon 18.5mm (Straight)
BRW780909/COVERF	Center Hubs Cab (Front) for 1.55"/1.9" Beadlock Wheels (2)
BRW780909/COVERR	Center Hubs Cab (Rear) for 1.55"/1.9" Beadlock Wheels (2)
BRW780955A	1.55" 16-Hole Classic Steelie Beadlock Front Faceplate (2) Gun Metal
BRW780955FGM	1.55" 16-Hole Classic Steelie Reversible Beadlock Wheels (Front) w/ XT500 Hubs (2) Gun Metal
BRW780955RGM	1.55" 16-Hole Classic Steelie Reversible Beadlock Wheels (Rear) w/ XT504 Hubs (2) Gun Metal
BRX01BBZ	High Performance Full Ball Bearings Set Rubber Sealed (32 Total)
BRX01FABBZ	High Performance Ball Bearings Set Rubber Sealed For Front Axle (10 Total)
BRX01GBBBZ	High Performance Ball Bearings Set Rubber Sealed For Gearbox (8 Total)
BRX01RABBZ	High Performance Ball Bearings Set Rubber Sealed For Rear Axle (8 Total)
BRX01TCBBZ	High Performance Ball Bearings Set Rubber Sealed For Transfer Case (6 Total)
BRXT504	XT504 Aluminum 12mm Wheel Hub Adapters 4mm Offset (2)
JX/PDI-HV115MG	JX Waterproof High Voltage Metal Gear Digital Mini Servo
KB/48601	Killerbody RC 1/10 LC70 Hard Body Set 313mm Version 2

If you have questions, call Boom Racing at:

1-209-676-8880 (USA) or email Boom Racing at [sales@boomracing.com](mailto:sales@boomracing.com)

[WWW.ENJOYBEINGABADASS.COM](http://WWW.ENJOYBEINGABADASS.COM)

BRX01

**"A FUTURE PROOF R/C KIT WITH UNLIMITED CONFIGURATIONS.  
BEAUTIFUL AS A "SHELF QUEEN" AND A TOTAL BEAST ON THE TRAILS!"**  
KRONIK BERT, KRONIX HOBBIES, GUAM U.S.A.

# BRX01

1/10TH 4WD RADIO CONTROL CHASSIS KIT FOR LC70

**"TORQUE TWIST IS NOW A THING OF THE PAST."** PADIM ISREAL, MANILA 4X4 SCALE RC, PHILIPPINES

**"THE AUDACIOUS & OUTWARD THINKING OF THE BRX01'S DESIGN COMBINED WITH THE MATERIAL QUALITY IS SECOND TO NONE.  
THIS ISN'T JUST ANOTHER NEW RC CRAWLER,  
THIS IS A MOMENT IN RC HISTORY AND THE BRX01 SETS A NEW STANDARD THAT ALL FUTURE RC CRAWLERS WILL FIND DIFFICULT TO LIVE UP TO."**  
MARK ROWE, WEST MICHIGAN RC CRAWLERS, U.S.A.

**"THE BRX01 IS LIKE A SWISS ARMY KNIFE. IT CAN DO EVERYTHING."**  
PG MAROL, RC4X4 BRUNEI, BRUNEI DARUSSALAM

**"THE CHASSIS AND ALL THE PARTS WERE VERY WELL THOUGHT OUT AND THE FIT AND FINISH IS TOP NOTCH. THE DRIVETRAIN IS NO JOKE,  
I'M VERY USED TO DEALING WITH THE RIGHT FRONT LIFT BUT THIS STAYED FLAT AND WAS VERY PREDICTABLE IN OFF-CAMBER AND TRANSITIONAL LINES.  
IT WAS ALSO QUIET AND EFFICIENT."**  
KEVIN MCPEEK, GILBERT AZ, U.S.A.

**"THE BRX01 IS THE CHASSIS TO GET IF YOU ARE INTO SCALE. COMPLETE, MODULAR AND TOUGH."**  
MOHAMMAD SHAHRIN MANDALAM, SIPUT PARK TROPHY, KUALA LUMPUR, MALAYSIA

**"THE FLEX IS REAL!"** PETER G, MANILA 4X4 SCALE RC, PHILIPPINES

**"THE BRX01 ISN'T JUST ONE STEP AHEAD; IT'S A GIANT LEAP FORWARD IN SCALE TRUCK DESIGN AND FUNCTIONALITY.  
YOU'VE NEVER SEEN A SCALE TRUCK DO WHAT THIS TRUCK CAN DO.  
BOOM RACING HAS CREATED A TRUCK THAT CAN EXCEL IN ALL AREAS FROM SHELF QUEEN TO TRAIL TRUCK TO COMPETITION CRAWLER."**  
JAY LENO, RC CULTURE, SWEDEN

**"IN ONE PRODUCT BOOM RACING HAS SET THE NEW STANDARD FOR EXCELLENCE IN THE R/C WORLD.  
THE BRX01 IS JUST SIMPLY UNBELIEVABLE, I HAVE NEVER IN MY WILDEST DREAMS BELIEVED A BOX STOCK TRUCK  
COULD EVER BE ABLE TO DO WHAT IT DOES AND LOOK SO DAMN GOOD DOING IT."**  
SHAWN ROCHE, GILBERT AZ, U.S.A.



**BOOMRACING**®  
*Your Radio Control Car Specialist*

**BRX01**

1/10TH 4WD RADIO CONTROL CHASSIS KIT FOR LC70

[WWW.ENJOYBEINGABADASS.COM](http://WWW.ENJOYBEINGABADASS.COM)